

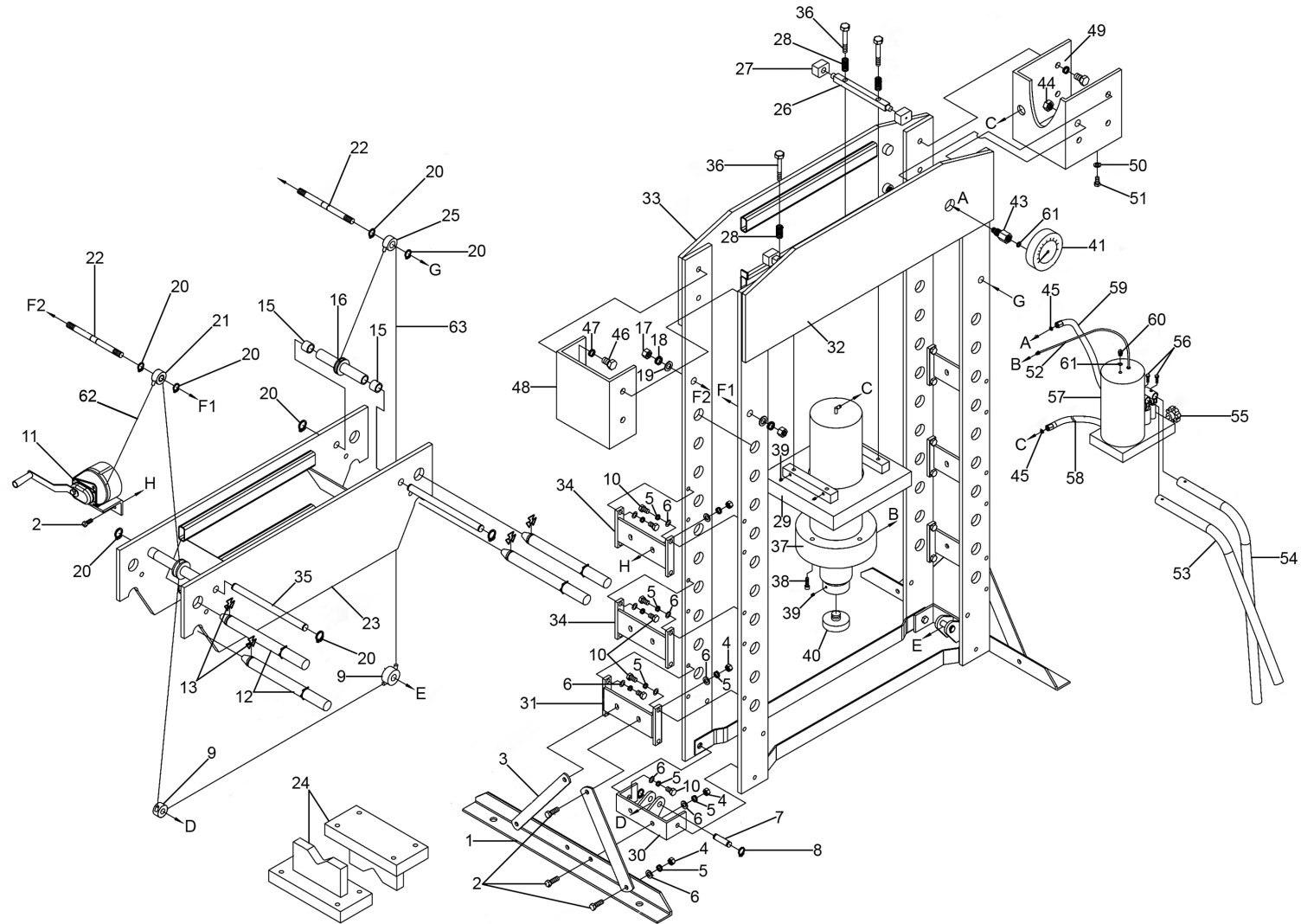

Parts Information:
Hydraulic Press 75 Tonne Floor Type
Model No: YK759F



NOTE: It is our policy to continually improve products and as such we reserve the right to alter data, specifications and component parts without prior notice.

There may be alternative versions of this product, please contact us should you require this information.

IMPORTANT: No liability is accepted for incorrect use of product. Spare parts must be fitted by a competent person

WARRANTY: Guarantee is 12 months from purchase date, proof of which will be required for any claim.

Sealey Group, Kempson Way, Suffolk Business Park, Bury St Edmunds, Suffolk. IP32 7AR



01284 757500



sales@sealey.co.uk



www.sealey.co.uk



Parts Information:
Hydraulic Press 75 Tonne Floor Type
Model No: YK759F

Item	Part No.	Description	Qty
1	YK759FAH.01	Base Section	2
2	SS1235.S	Hex Head Set Screw M12 x 35mm	14
3	YK759FAH.03	Support	4
4	SN12.S	Steel Nut M12	48
5	SWM12.S	Spring Washer M12	32
6	FWM12.S	Flat Washer M12	32
7	YK759FAH.07	Pin	2
8	600TR/27	External Circlip 14.5mm ID.	4
9	YK759FAH.09	Roller	2
10	SS1230.S	Hex Head Set Screw M12 x 30mm	16
11	YK759F.11	Hand Winch	1
12	YK759F.12	Pin, Bed Frame	4
13	YK759FAH.13	Retaining Clip	8
15	YK759FAH.15	Bush	2
16	YK759FAH.16	Shaft Wheel	1
17	SN20.S	Steel Nut M20	2
18	SWM20.S	Spring Washer M20	2
19	FWM20.S	Flat Washer M20	2
20	YK759FAH.20	External Circlip 18.3mm ID.	4
21	YK759FAH.21	Roller	1
22	YK759F.22	Bolt	2
23	YK759FAH.23	Bed Frame	1
24	YK759FAH.24	V-Block	2
25	YK759FAH.25	Roller	1
26	YK759F.26	Connecting Rod	2
27	B/6202ZZ	Bearing	4
28	YK759FAH.28	Spring Ø 16.9mm	4
29	YK759FAH.29	Under Plate	1
30	YK759FAH.30	Connecting Plate 1	1
31	YK759F.31	Connecting Plate 2	1
32	YK759F.32	Post 1	1
33	YK759F.33	Post 2	1
34	YK759FAH.34	Connecting Plate 3	4
35	YK759FAH.35	Pin	2
36	HHB10100.S	Hex Head Bolt M10 x 100mm	4
37	YK759F.37	Ram Assembly	1

Item	Part No.	Description	Qty
38	SCB1035.SB	Socket Cap Bolt M10 x 35mm Black	4
39	GSM810.S	Grub Screw M8 x 10mm	4
40	YK759FAH.40	Saddle, Serrated (M) Ø 78mm (Shaft Ø 25mm)	1
41	YK759FAH.41	Gauge, 120T Ø110mm BTM Fitting (1000KgF/cm ²)	1
43	YK759FAH.43	Gauge Fitting	1
44	YK309FAH.24	Half Nut, Fine Pitch M20 x 1.5mm	1
45	AK458DX.V4-20	O-Ring (8.84 x 5.28 x 1.78)	2
46	SS1630.S	Hex Head Set Screw M16 x 30mm	2
47	SWM16.S	Spring Washer M16	2
48	YK759FAH.48	Connecting Plate 4	1
49	YK759FAH.49	Connecting Plate 5	1
50	FWM10.S	Flat Washer M10	4
51	SS1020.S	Hex Head Set Screw M10 x 20mm	4
52	YK759F.52	Oil Hose 4 x 6 x 1180mm	1
53	YK759F.53	Handle 1	1
54	YK759FAH.54	Handle 2	1
55	YK509FAH.50	Release Valve	1
56	SS820.S	Hex Head Set Screw M8 x 20mm	2
57	YK759F.57N	Pump Assembly	1
58	YK759FAH.58	Oil Hose 1 (740mm)	1
59	YK759FAH.59	Oil Hose 2 (1420mm)	1
60	YK759F.60	Oil Filler Nut	1
61	YK759FAH.61	Nylon Ring	2
62	YK759FAH.67	Cable 1	1
63	YK759FAH.68	Cable 2	1
--	YK759FAH.P3	Plastic Roller Cover(P.9) (Not Shown)	--
--	YK759FAH.P1	Plastic Roller Cover (P.21) (Not Shown)	--
--	YK759FAH.P2	Plastic Roller Cover (P.25) (Not Shown)	--
--	YK759F.64	Ram Connector, Oil Hose (Not Shown)	--
--	YK759F.65	Seal Kit, Pump (Not Shown)	--
--	YK759FAH.CC	Cable Clamp (Not Shown)	--
--	YK759F.JC	Joining Clip (Not Shown)	--
--	KP-30A-1948	Cable Clamp (Not Shown)	--

NOTE: It is our policy to continually improve products and as such we reserve the right to alter data, specifications and component parts without prior notice. There may be alternative versions of this product, please contact us should you require this information.

IMPORTANT: No liability is accepted for incorrect use of product. Spare parts must be fitted by a competent person

WARRANTY: Guarantee is 12 months from purchase date, proof of which will be required for any claim.

Sealey Group, Kempson Way, Suffolk Business Park, Bury St Edmunds, Suffolk. IP32 7AR



01284 757500



sales@sealey.co.uk



www.sealey.co.uk