

Item	Part No.	Description
8	MG-2/C9	SAFETY VALVE
9	YK50FM/64	SCREW
14	KPM-30/2133	BUSHING
16	YK50FM/42	HANDLE SOCKET
17	KMM-15/1366	CLIP

Item	Part No.	Description
18	YK50FAH/37	PLUG
21	A-5578	CONNECTOR
22	A-5110	GAUGE 700kg/cm2,100mm OD, Back Fitting.
48	ME-12001/1139	FILLER PLUG
52	YK50FAH/RK	REPAIR KIT

NOTE: It is our policy to continually improve products and as such we reserve the right to alter data, specifications and component parts without prior notice.

IMPORTANT: No liability is accepted for incorrect use of product.

WARRANTY: Guarantee is 12 months from purchase date, proof of which will be required for any claim.

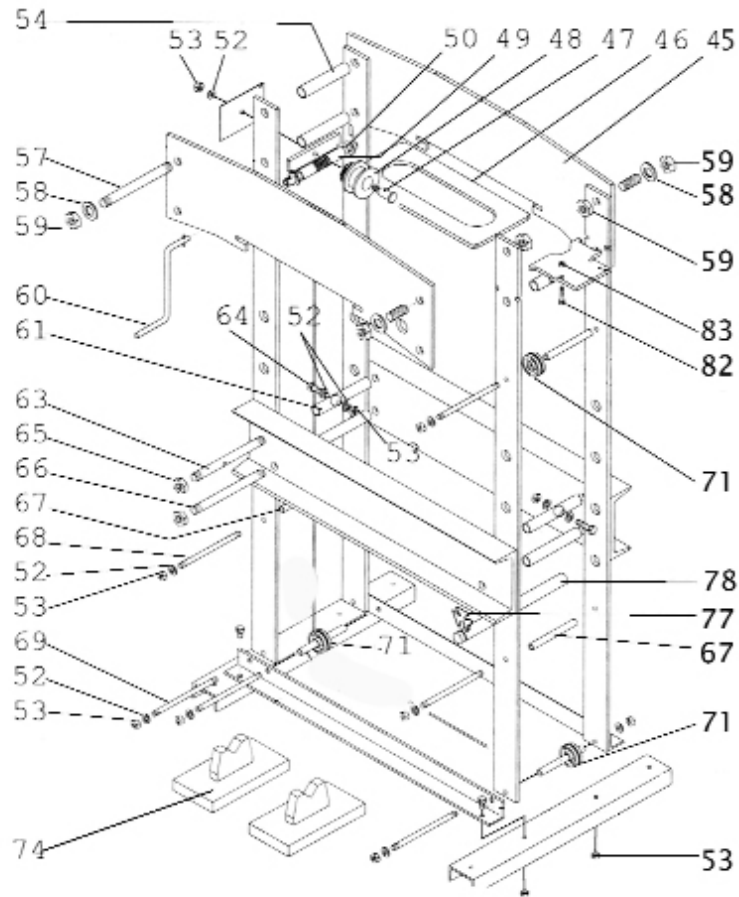

Item	Part No.	Description
46	YK30FAH/46	CYLINDER SUPPORT
47	YK50FAH/66	AXLE
48	YK50FM/48	PULLEY,WORM GEAR
49	KPM-30/1957	WORM GEAR SHAFT
50	YK50FM/58	WASHER M22
52	YK50FM/50	WASHER
53	YK50FAH/59	NUT
54	KPM-30/1815	BUSHING
57	KPM-30/1670	AXLE
58	YK50FM/58	WASHER M22
59	YK50FAH/83	NUT
60	YK50FM/35	HANDLE,PUMPING
61	KPM-30/1370-S	BUSHING

Item	Part No.	Description
63	KPM-30/1367	AXLE
64	YK50FM/64	SCREW
65	YK50FAH/59	NUT
66	KPM-30/1367-S	AXLE
67	KPM-30/2206	BUSHING
68	KPM-30/1264	AXLE
69	KPM-30/1367	AXLE
71	YK50FM/71	PULLEY
74	KCK-50A/C15	V BLOCK
77	KMM-15/1366	CLIP
78	MG-2/1344	AXLE
82	EF-1.5/1315	BOLT M8X40
83	YK50FAH/59	NUT

NOTE: It is our policy to continually improve products and as such we reserve the right to alter data, specifications and component parts without prior notice.

IMPORTANT: No liability is accepted for incorrect use of product.

WARRANTY: Guarantee is 12 months from purchase date, proof of which will be required for any claim.



Parts Information:
**Air/Hydraulic Press 50tonne Floor
Type Model No: YK50FAH**

Item	Part No.	Description
--	YK50FM/03	RELEASE VALVE KNOB (NOT SHOWN)
--	MG-2/1130	O-RING (NOT SHOWN)
--	SB-8.0	STEEL BALL 8.0mm (NOT SHOWN)
--	SB-5.6	STEEL BALL 5.6mm (NOT SHOWN)
--	MB-22-A/1286	CIRCLIP (NOT SHOWN)
--	MG-2/1161	CIRCLIP (NOT SHOWN)
--	MG-2/1133	SEAL (NOT SHOWN)
--	BK05-C7M	HANDLE SOCKET ASS'Y (NOT SHOWN)
--	MB-22-A/1130	O-RING (NOT SHOWN)
--	YK50FAH/18	CIRCLIP (NOT SHOWN)
--	YK50FM/20	CONNECTOR (NOT SHOWN)
--	YK50FAH/21	PIPE (NOT SHOWN)
--	CMK-50	RAM (NOT SHOWN)
--	YK50FM/23	RING (NOT SHOWN)
--	ME50001/1134H	SEAL (NOT SHOWN)
--	CSK-50/1164	RING (NOT SHOWN)
--	CSK-50/1348	O-RING (NOT SHOWN)
--	CMK-50	RAM (NOT SHOWN)
--	YK50FAH/30	SPRING (NOT SHOWN)
--	YK50FAH/31	GUIDE PISTON (NOT SHOWN)
--	YK50FAH/32	PISTON HEAD (NOT SHOWN)

Item	Part No.	Description
--	ME-1501/1162	SPRING (NOT SHOWN)
--	BKN-09	AIR AND HYDRAULIC PUMP COMPLETE (NOT SHOWN)
--	ME-1501/1134	SEAL (22x12.5x7) (NOT SHOWN)
--	YK50FM/40	O-RING (NOT SHOWN)
--	YK50FAH/41	O-RING (NOT SHOWN)
--	YK50FAH/45	FRAME (NOT SHOWN)
--	YK50FM/51	COVER (NOT SHOWN)
--	YK50FAH/55	UPRIGHT (NOT SHOWN)
--	YK50FAH/56	FRAME (NOT SHOWN)
--	KPM-30/1197	AXLE (NOT SHOWN)
--	YK50FAH/62	TABLE (NOT SHOWN)
--	SN20.S	STEEL NUT M20 ZINC DIN934(SINGLE) (NOT SHOWN)
--	YK50FAH/73	CROSS SECTION (NOT SHOWN)
--	KMM-30/1333	SCREW (NOT SHOWN)
--	YK50FM/76	FOOT (NOT SHOWN)
--	YK50FAH/78	AXLE (250mm x 35mm dia) (NOT SHOWN)
--	YK50FAH/81	UPRIGHT (NOT SHOWN)
--	BKN-09	AIR AND HYDRAULIC PUMP COMPLETE (NOT SHOWN)

NOTE: It is our policy to continually improve products and as such we reserve the right to alter data, specifications and component parts without prior notice.

IMPORTANT: No liability is accepted for incorrect use of product.

WARRANTY: Guarantee is 12 months from purchase date, proof of which will be required for any claim.

Sealey Group, Kempson Way, Suffolk Business Park, Bury St Edmunds, Suffolk. IP32 7AR



01284 757500



01284 703534



sales@sealey.co.uk



www.sealey.co.uk