

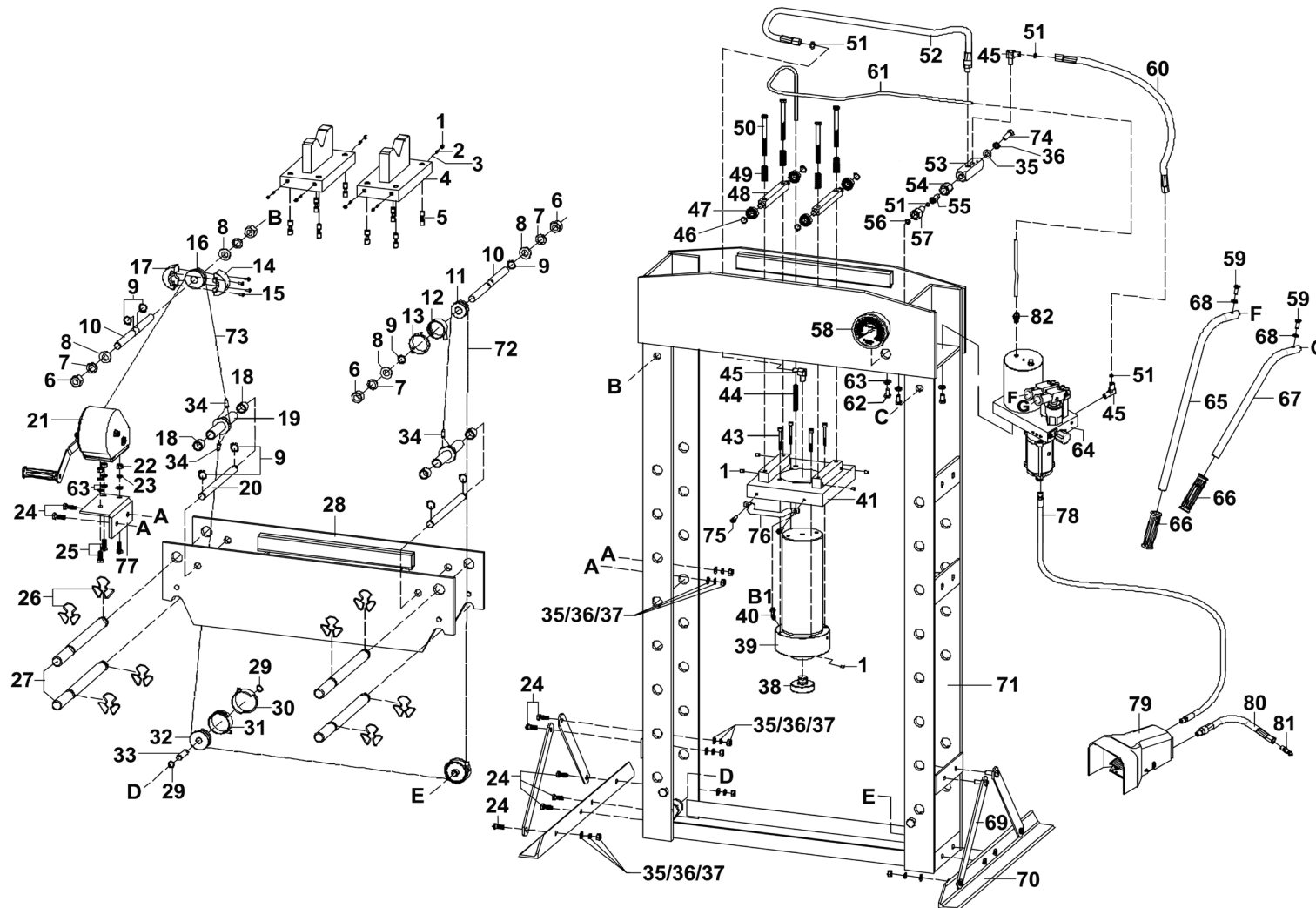

Parts Information:
Premier Air/Hydraulic Floor Type Press with Foot Pedal 50 Tonne
Model No: YK509FAH.V2



NOTE: It is our policy to continually improve products and as such we reserve the right to alter data, specifications and component parts without prior notice.

There may be alternative versions of this product, please contact us should you require this information.

IMPORTANT: No liability is accepted for incorrect use of product. Spare parts must be fitted by a competent person

WARRANTY: Guarantee is 12 months from purchase date, proof of which will be required for any claim.

Sealey Group, Kempson Way, Suffolk Business Park, Bury St Edmunds, Suffolk. IP32 7AR



01284 757500



sales@sealey.co.uk



www.sealey.co.uk



Parts Information:
**Premier Air/Hydraulic Floor Type Press
 with Foot Pedal 50 Tonne
 Model No: YK509FAH.V2**

Item	Part No.	Description	Qty
1	GSM810.S	Grub Screw M8 x 10mm	13
2	YK509FAH.V2-02	Spring Ø 4.8mm	8
3	SB-5.6	Steel Ball 5.6mm	8
4	YK509FAH.V2-04	V-Block	2
5	YK509FAH.V2-05	Roller	8
6	YK509FAH.V2-06	Nut	4
7	YK509FAH.V2-07	Washer	4
8	YK509FAH.V2-08	Spring Washer	4
9	SM353CEV2.048	External Circlip ID: 18.4mm	8
10	YK509FAH.V2-10	Threaded Rod	2
11	YK509FAH.V2-11	Roller	1
12	YK509FAH.V2-12	Protective Housing C	1
13	YK509FAH.V2-13	Protective Housing D	1
14	YK509FAH.V2-14	Protective Housing A	1
15	YK509FAH.V2-15	Screw	4
16	YK509FAH.V2-16	Roller	1
17	YK509FAH.V2-17	Protective Housing B	1
18	YK509FAH.V2-18	Bush	4
19	YK509FAH.V2-19	Shaft Wheel	2
20	YK509FAH.V2-20	Pin M20 x 275mm	2
21	YK509FAH.V2-21	Hand Winch	1
22	SN10.S	Steel Nut M10	3
23	SWM10.S	Spring Washer M10	3
24	SS1235.S	Hex Head Set Screw M12 x 35mm	14
25	SS1025.S	Hex Head Set Screw M10 x 25mm	3
26	YK509FAH.V2-26	Retaining Clip	8
27	YK509FAH.V2-27	Pin, Table Support 400 x 30mm	4
28	YK509FAH.V2-28	Bed Frame	1
29	YK509FAH.V2-29	Ring	4
30	YK509FAH.V2-30	Protective Housing E	2
31	YK509FAH.V2-31	Protective Housing F	2
32	YK509FAH.V2-32	Roller	2
33	YK509FAH.V2-33	Roller Pin	2
34	YK509FAH.V2-34	Cable Protection	3
35	FWM12.S	Flat Washer M12	15
36	SWM12.S	Spring Washer M12	15
37	SN12.S	Steel Nut M12	14
38	YK509FAH.V2-38	Saddle (Serrated)	1
39	YK509FAH.V2-39	Ram Assembly	1
40	YK509FAH.V2-40	Air Hose Connection	1
41	YK509FAH.V2-41	Under Plate	1

Item	Part No.	Description	Qty
43	YK509FAH.V2-43	Screw	4
44	YK509FAH.V2-44	Spring	1
45	YK509FAH.V2-45	Elbow Fitting	3
46	YK509FAH.V2-46	Retaining Ring	4
47	B/6202ZZ	Bearing 6202ZZ	4
48	YK509FAH.V2-48	Connecting Rod	2
49	YK509FAH.V2-49	Spring Ø 16.5mm	4
50	HHB10100.S	Hex Head Bolt M10 x 100mm	4
51	AK458DX.V4-20	O-Ring (8.84 x 5.28 x 1.78mm)	4
52	YK509FAH.V2-52	Oil Hose 2	1
53	YK509FAH.V2-53	Holddown	1
54	YK509FAH.V2-54	Deep Nut	1
55	YK509FAH.V2-55	Banjo Fixing	1
56	YK509FAH.V2-56	Nylon Ring	1
57	YK509FAH.V2-57	Gauge Fitting	1
58	YK509FAH.V2-58	Pressure Gauge 1000Kgf/cm ² 80T Ø 110mm Rear Fitting	1
59	SS820.S	Hex Head Set Screw M8 x 20mm	2
60	YK509FAH.V2-60	Oil Hose 20mm x 270mm	1
61	YK509FAH.V2-61	Oil Hose (6 x 8 x 1340mm)	1
62	YK509FAH.V2-62	Screw	3
63	FWM10.S	Flat Washer M10	6
64	YK509FAH.V2-64	Pump Assembly	1
65	YK509FAH.V2-65	Handle	1
66	YK509FAH.V2-66	Handle Grip	2
67	YK509FAH.V2-67	Handle 1	1
68	FWM8.S	Flat Washer M8	2
69	YK509FAH.V2-69	Support	4
70	YK509FAH.V2-70	Base Section	2
71	YK509FAH.V2-71	Frame	1
72	YK509FAH.V2-72	Cable A	1
73	YK509FAH.V2-73	Cable B	1
74	SS1225.S	Hex Head Set Screw M12 x 25mm	1
75	YK509FAH.V2-75	Screw For Carry Handle	2
76	YK509FAH.V2-76	Carry Handle	1
77	YK509FAH.V2-77	Plate For Hand Winch	1
78	YK509FAH.V2-78	Air Hose 179mm	1
79	YK509FAH.V2-79	Foot Pedal	1
80	YK509FAH.V2-80	Air Hose 15mm x 230mm	1
81	YK509FAH.V2-81	Quick Coupler (M)	1
82	YK509FAH.V2-82	Oil Filler Nut	1

NOTE: It is our policy to continually improve products and as such we reserve the right to alter data, specifications and component parts without prior notice. There may be alternative versions of this product, please contact us should you require this information.

IMPORTANT: No liability is accepted for incorrect use of product. Spare parts must be fitted by a competent person

WARRANTY: Guarantee is 12 months from purchase date, proof of which will be required for any claim.

Sealey Group, Kempson Way, Suffolk Business Park, Bury St Edmunds, Suffolk. IP32 7AR



01284 757500



sales@sealey.co.uk



www.sealey.co.uk