

Parts Information:  
**Premier Air/Hydraulic Floor Type Press  
 with Foot Pedal 30 Tonne  
 Model No: YK309FAH.V2**

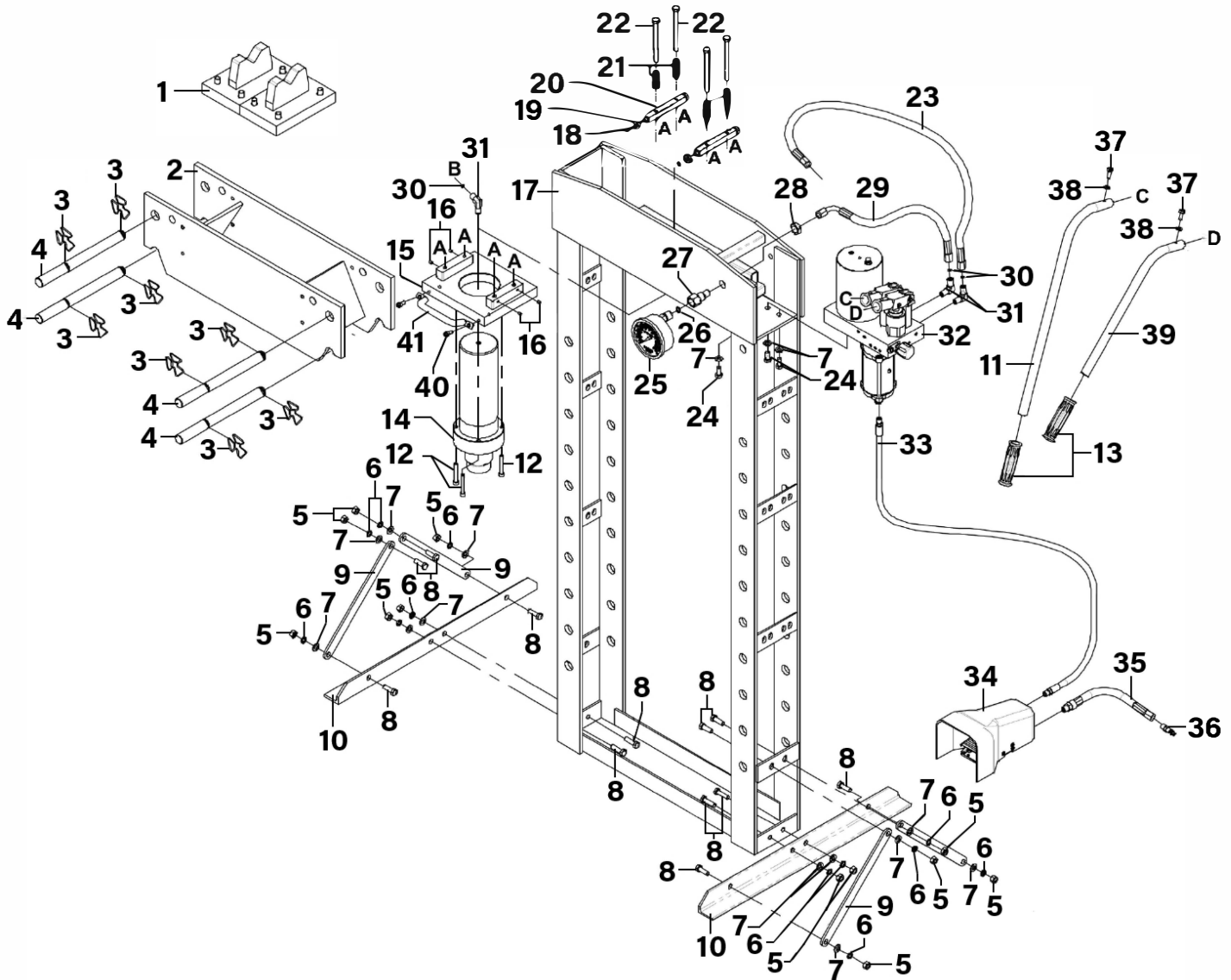

Item	Part No.	Description	Qty
1	YK309FAH.V2-01	V-Block	2
2	YK309FAH.V2-02	Bed Frame	1
3	YK309FAH.V2-03	Circlip	8
4	YK309FAH.V2-04	Bed Frame Pin	4
5	SN10.S	Steel Nut M10	12
6	FWM10.S	Flat Washer M10	12
7	SWM10.S	Spring Washer M10	15
8	SS1025.S	Hex Head Set Screw M10 x 25mm	12

Item	Part No.	Description	Qty
9	YK309FAH.V2-09	Support	4
10	YK309FAH.V2-10	Base Section	2
11	YK309FAH.V2-11	Handle	1
12	YK309FAH.V2-12	Bolt for Ram Assembly	4
13	YK309FAH.V2-13	Handle Grip	2
14	YK309FAH.V2-14	Ram Assembly	1
15	YK309FAH.V2-15	Upper Plate	1
16	GSM68.S	Grub Screw M6 x 8 mm	4

**NOTE:** It is our policy to continually improve products and as such we reserve the right to alter data, specifications and component parts without prior notice. There may be alternative versions of this product, please contact us should you require this information.

**IMPORTANT:** No liability is accepted for incorrect use of product. Spare parts must be fitted by a competent person

**WARRANTY:** Guarantee is 12 months from purchase date, proof of which will be required for any claim.



Parts Information:  
**Premier Air/Hydraulic Floor Type Press  
with Foot Pedal 30 Tonne  
Model No: YK309FAH.V2**

Item	Part No.	Description	Qty
17	YK309FAH.V2-17	Frame	1
18	YK309FAH.V2-18	R-Pin	4
19	YK309FAH.V2-19	Roller	4
20	YK309FAH.V2-20	Link Rod	2
21	YK309FAH.V2-21	Spring Ø 16.8mm	4
22	HHB10120.S	Hex Head Bolt M10 x 120mm	4
23	YK309FAH.V2-23	Oil Hose (2)	1
24	SS1020.S	Hex Head Set Screw M10 x 20mm	3
25	YK309FAH.V2-25	Gauge 1000Kgf/cm <sup>2</sup> 50T Ø 110mm Rear Fitting	1
26	YK309FAH.V2-26	Nylon Ring	1
27	YK309FAH.V2-27	Gauge Fitting	1
28	YK309FAH.V2-28	M20 x 1.5mm Fine Pitch Half Nut	1
29	YK309FAH.V2-29	Oil Hose (1)	1

Item	Part No.	Description	Qty
30	PWDM3600.P28	O-Ring (8.32 x 4.76 x 1.78mm)	3
31	YK309FAH.V2-31	Elbow For Ram/Pump Assembly	3
32	YK309FAH.V2-32	Pump Assembly	1
33	YK309FAH.V2-33	Air Hose	1
34	YK309FAH.V2-34	Foot Pedal	1
35	YK309FAH.V2-35	Air Hose 16mm x 200mm	1
36	YK309FAH.V2-36	Quick Coupler (Male)	1
37	SS820.S	Hex Head Set Screw M8 x 20mm	2
38	FWM8.S	Flat Washer M8	2
39	YK309FAH.V2-39	Handle	1
40	YK309FAH.V2-40	Screw for Carry Handle	1
41	YK309FAH.V2-41	Carry Handle	2

**NOTE:** It is our policy to continually improve products and as such we reserve the right to alter data, specifications and component parts without prior notice. There may be alternative versions of this product, please contact us should you require this information.

**IMPORTANT:** No liability is accepted for incorrect use of product. Spare parts must be fitted by a competent person

**WARRANTY:** Guarantee is 12 months from purchase date, proof of which will be required for any claim.

Sealey Group, Kempson Way, Suffolk Business Park, Bury St Edmunds, Suffolk. IP32 7AR



01284 757500



sales@sealey.co.uk



www.sealey.co.uk