

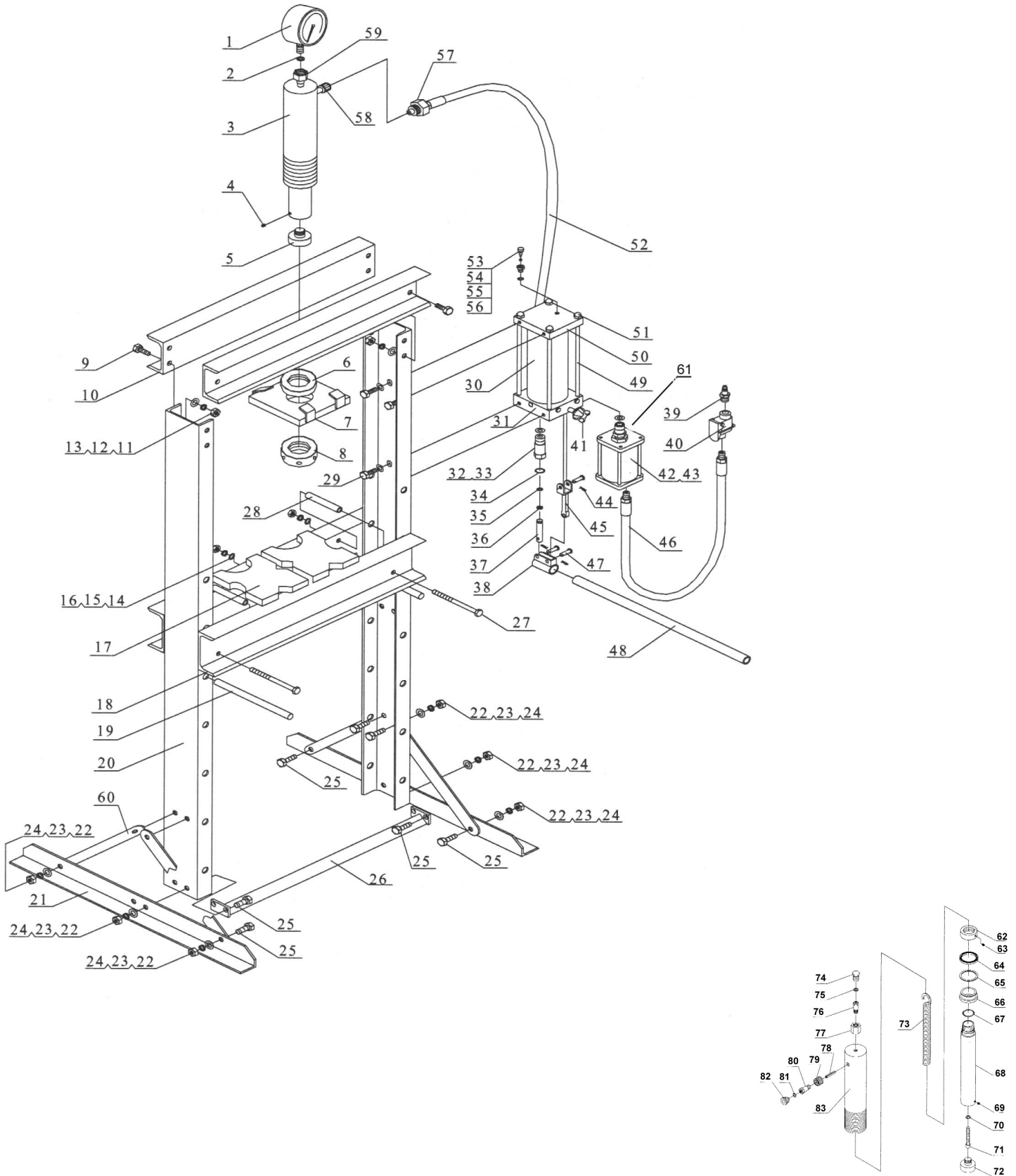

Parts Information:
Air/Hydraulic Press Yankee 20tonne Floor
Type
Model No: YK20FAH



NOTE: It is our policy to continually improve products and as such we reserve the right to alter data, specifications and component parts without prior notice.

IMPORTANT: No liability is accepted for incorrect use of product.

WARRANTY: Guarantee is 12 months from purchase date, proof of which will be required for any claim.

Sealey Group, Kempson Way, Suffolk Business Park, Bury St Edmunds, Suffolk. IP32 7AR



01284 757500



01284 703534



sales@sealey.co.uk



www.sealey.co.uk



Parts Information:
**Air/Hydraulic Press Yankee 20tonne Floor
Type
Model No: YK20FAH**

Item	Part No.	Description
1	YK20FAH.01	Gauge1000kgf/cm2 28t 110mm od btm Fitting
2	YK759FAH.61	Nylon Ring
3	YK20FAH.RC	Hydraulic Ram Complete.
4	YK20FAH.04	Grub Screw m6x5
5	YK20FAH.05	Serrated Saddle
6	YK20FAH.06	Round Nut, Upper Ring
7	YK20FAH.07	Plate
8	YK20FAH.08	Round Nut, Lower
9	YK20FAH.09	Bolt m16x35
10	YK20FAH.10	Cross Beam, Upper
11	SN16.S	Steel Nut m16 Zinc din934(Single)
12	SWM16.S	Spring Washer m16 Zinc (Single)
13	FWM16.S	Flat Washer m16 Single
14	FWM10.S	Flat Washer m10 Single
15	SWM10.S	Spring Washer m10 Zinc (Single)
16	SN10.S	Steel Nut m10 Zinc din934(Single)
17	YK20FV3-17	V Block (190x100x30)
18	YK20FAH.18	Press Bed Frame
19	YK20FV3-19	Pin, Table Support 250x25mm
20	YK20FAH.20	Frame Post
21	YK20FAH.21	Base Section
22	FWM12.S	Flat Washer m12 Single
23	SWM12.S	Spring Washer m12 Zinc (Single)
24	SN12.S	Steel Nut m12 Zinc din934(Single)
25	SS1015.S	Hex Head Set Screw m10x15mm Single
26	YK20FAH.26	Lower Cross Member
27	HHB10130.S	Hex Head Bolt m10x130mm Single
28	YK20FAH.28	Bushing
29	SS1016.S	Hex Head Set Screw m10x16mm Single
30	YK20FAH.30	Reservoir
31	YK20FAH.31	Pump Assy
32	YK20FAH.32	Ring
33	YK20FAH.33	Small Pump Cylinder
34	YK20FAH.34	Ring
35	YK20FAH.35	O-Ring
36	YK20FAH.36	Nylon Ring
37	YK20FAH.37	Small Pumping Piston
38	YK20FAH.38	Handle Bracket
39	YK20FAH.39	Air Inlet Filter
40	YK20FAH.40	Air Valve
41	YK20FAH.41	Release Valve
42	YK20FAH.42	Ring

Item	Part No.	Description
43	YK20FAH.43	Air Motor
44	YK20FAH.44	R-Clip
45	YK20FAH.45	Tie Rod
46	YK20FAH.46	Air Hose
47	YK20FAH.47	Pin
48	YK30F.27	Handle
49	YK20FAH.49	Bolt
50	YK20FAH.50	Plate
51	SN10.SD	Steel Nut m10 domed (Single)
52	YK20FAH.52	Hydraulic Hose
53	YK20FAH.53	Screw
54	YK20FAH.54	Sealing Ring
55	YK20FAH.55	Oil Filler Nut
56	YK20FAH.56	Nylon Ring
57	YK20FAH.57	Hose Fitting
58	YK20FAH.58	Connection Nut
59	YK20FAH.R15	Gauge Coupler
--	YK509FAH.60	Deep Nut (NOT SHOWN)
60	YK20FAH.60	Support
61	YK20FAH.61	Air Motor Plate
62	YK20FAH.R01	Circular Nut
63	GSM66.S	Grub Screw m6x6 (Single)
64	YK20FAH.R03	Sealing Ring
65	YK20FAH.R04	Ring
66	YK20FAH.R05	Bushing
67	YK20FAH.R06	O-Ring
68	YK20FAH.R07	Ram
69	YK20FAH.R08	Screw m6x10
70	YK20FAH.R09	Sealing Washer
71	YK20FAH.R10	Bolt m10
72	YK20FAH.R11	Toe
73	YK20FAH.R12	Spring
74	YK20FAH.R13	Screw
75	YK759FAH.61	Nylon Ring
76	YK20FAH.R15	Gauge Coupler
77	YK509FAH.60	Deep Nut
78	YK20FAH.R17	Pin
79	YK20FAH.R18	Connection Nut
80	YK20FAH.R19	Coupler
81	YK20FAH.R20	O-Ring
82	YK20FAH.R21	Dust Cap
83	YK20FAH.R22	Cylinder

NOTE: It is our policy to continually improve products and as such we reserve the right to alter data, specifications and component parts without prior notice.

IMPORTANT: No liability is accepted for incorrect use of product.

WARRANTY: Guarantee is 12 months from purchase date, proof of which will be required for any claim.

Sealey Group, Kempson Way, Suffolk Business Park, Bury St Edmunds, Suffolk. IP32 7AR



01284 757500



01284 703534



sales@sealey.co.uk



www.sealey.co.uk