

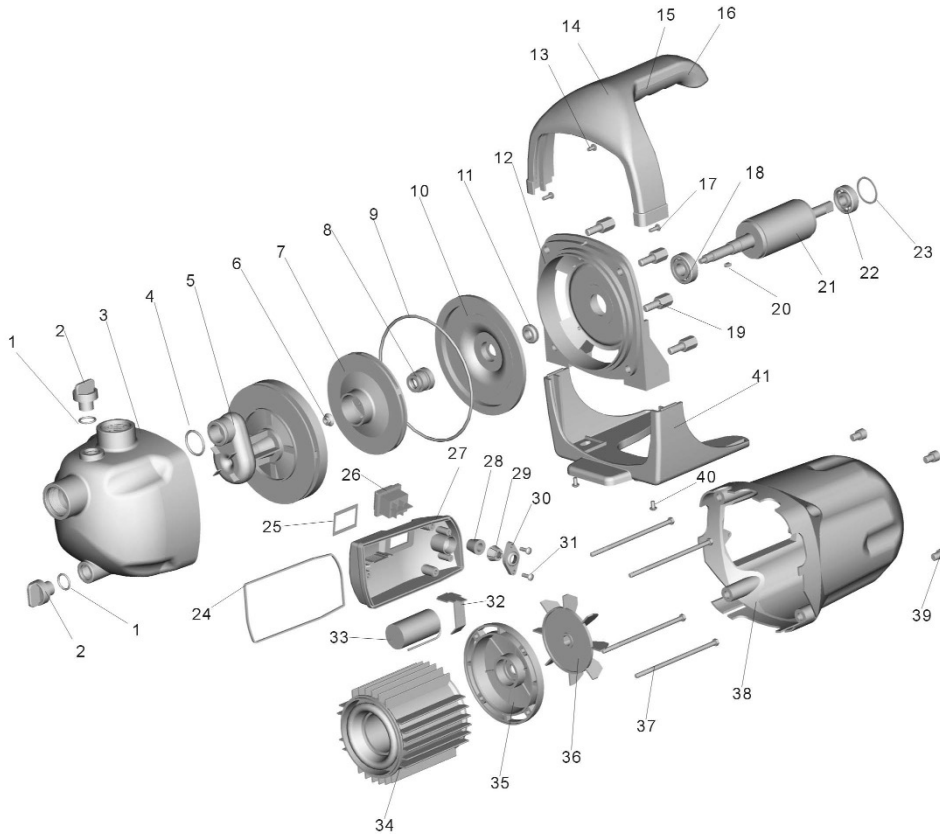

Parts Information:
**Surface Mounting Water Pump 60ltr/min
 230V
 Model No: WPS060**



Item	Part No.	Description
1	WPS060.01	Sealing O-Ring
2	WPS060.02	Plug
3	WPS060.03	Pump Body
4	WPS060.04	Sealing O-Ring
5	WPS060.05	Diffuser
6	NLN10.S	Nyloc Nut M10 Zinc (Single)
7	WPS060.07	Impeller
8	WPS060.08	Mechanical Seal
9	WPS060.09	Sealing O-Ring
10	WPS060.10	Pump Support Cover
11	WPS060.11	Water Proof Gland
12	WPS060.12	Frame
13	WPS060.13	Screw
14	WPS060.14	Handle
15	WPS060.15	Handle Grip
16	WPS060.16	Self-Driving Screw
17	WPS060.17	Self-Driving Screw
18	B/6202-2RS	Bearing 6202-2RS
19	WPS060.19	Plug
20	WPS060.20	Shaft Key
21	WPS060.21	Rotor

Item	Part No.	Description
22	B/6201-2RS	Bearing 6201-2RS
23	WPS060.23	Wave Spring
24	WPS060.24	Seal Ring
25	WPS060.25	Seal Cushion For Switch
26	WPS060.26	Waterproof Switch
27	WPS060.27	Terminal Box
28	WPS060.28	Seal Cover
29	WPS060.29	Wire Buckle
30	WPS060.30	Impact Cover
31	WPS060.31	Self-Driving Screw
32	WPS060.32	Capacitor Clip
33	WPS060.33	Capacitor (16uf)450V 50/60HZ 70x35
34	WPS060.34	Motor Stator
35	WPS060.35	End Plate
36	WPS060.36	Fan
37	WPS060.37	Bolt M5x135
38	WPS060.38	Pump Cover
39	WPS060.39	SKT. HD Bolt M8x10
40	WPS060.40	Self-Driving Screw
41	WPS060.41	Pump Base

NOTE: It is our policy to continually improve products and as such we reserve the right to alter data, specifications and component parts without prior notice.

IMPORTANT: No liability is accepted for incorrect use of product.

WARRANTY: Guarantee is 12 months from purchase date, proof of which will be required for any claim.

Sealey Group, Kempson Way, Suffolk Business Park, Bury St Edmunds, Suffolk. IP32 7AR



01284 757500



01284 703534



sales@sealey.co.uk



www.sealey.co.uk