

Issue: 2  
Date Issued: 24/02/2009

Item	Part No.	Description	Qty
1	153/29500003	Complete Pump	1
1a	153/21700010	Air Inlet Valve	1
1b	153/441A00026	Silencer	1
2	153/18000061	Drain Hose	1
3	153/25200046	Suction Hose	1
4	153/27600010	Hose Clamp	1
5	153/14900016	Wheel, Ø150mm	2
6	153/26900023	Toothed Lock Washer	2
7	153/29500009	Nozzle, Ø10.5mm	1
8	153/29500008	Nozzle, Ø8.5mm	1
9	153/29500007	Nozzle, Ø6.5mm	1
10	153/29500012	Nozzle, M14	1
11	153/29500011	Nozzle, M12	1
12	153/29500010	Nozzle, M10	1
13	153/14200015	Teflon Washer	1
14	153/29500013	Self-Locking Nut, M14	1
15	153/146N00009	Self-Locking Nut, M12	1
16	153/135.00024	Self-Locking Nut, M10	1
17	153/29500002	Spacer	1
18	153/26100005	Fitting Ø12	1
	153/41700009	Sleeve F/F	1
19	153/18000009	Fitting Ø12	1
	153/41700012	Extension Piece	1

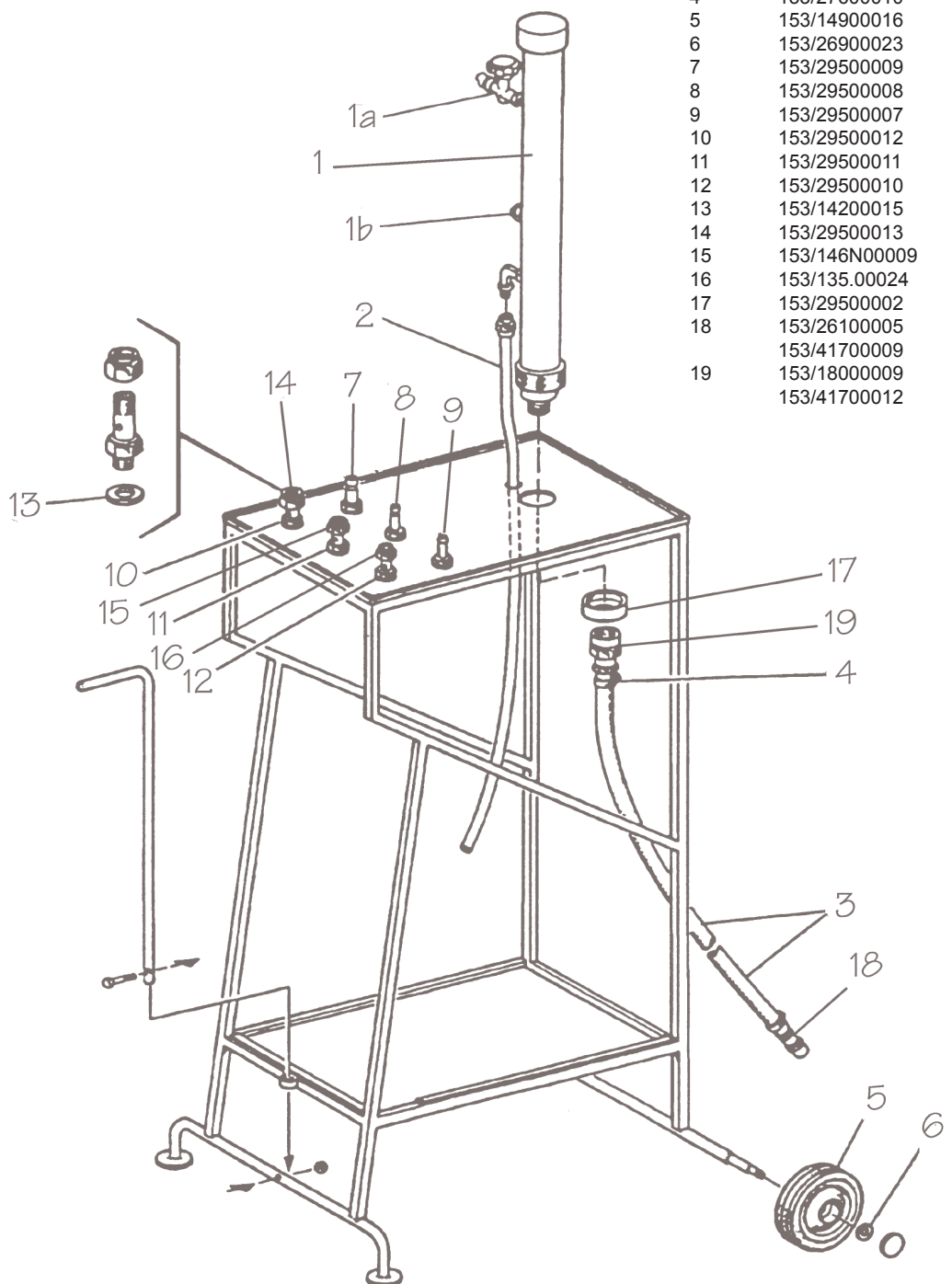

**NOTE:** It is our policy to continually improve products and as such we reserve the right to alter data, specifications and component parts without prior notice.

**IMPORTANT:** No liability is accepted for incorrect use of product.

**WARRANTY:** Guarantee is 12 months from purchase date, proof of which will be required for any claim.

**INFORMATION:** For a copy of our latest catalogue and promotions call us on 01284 757525 and leave your full name and address, including postcode.

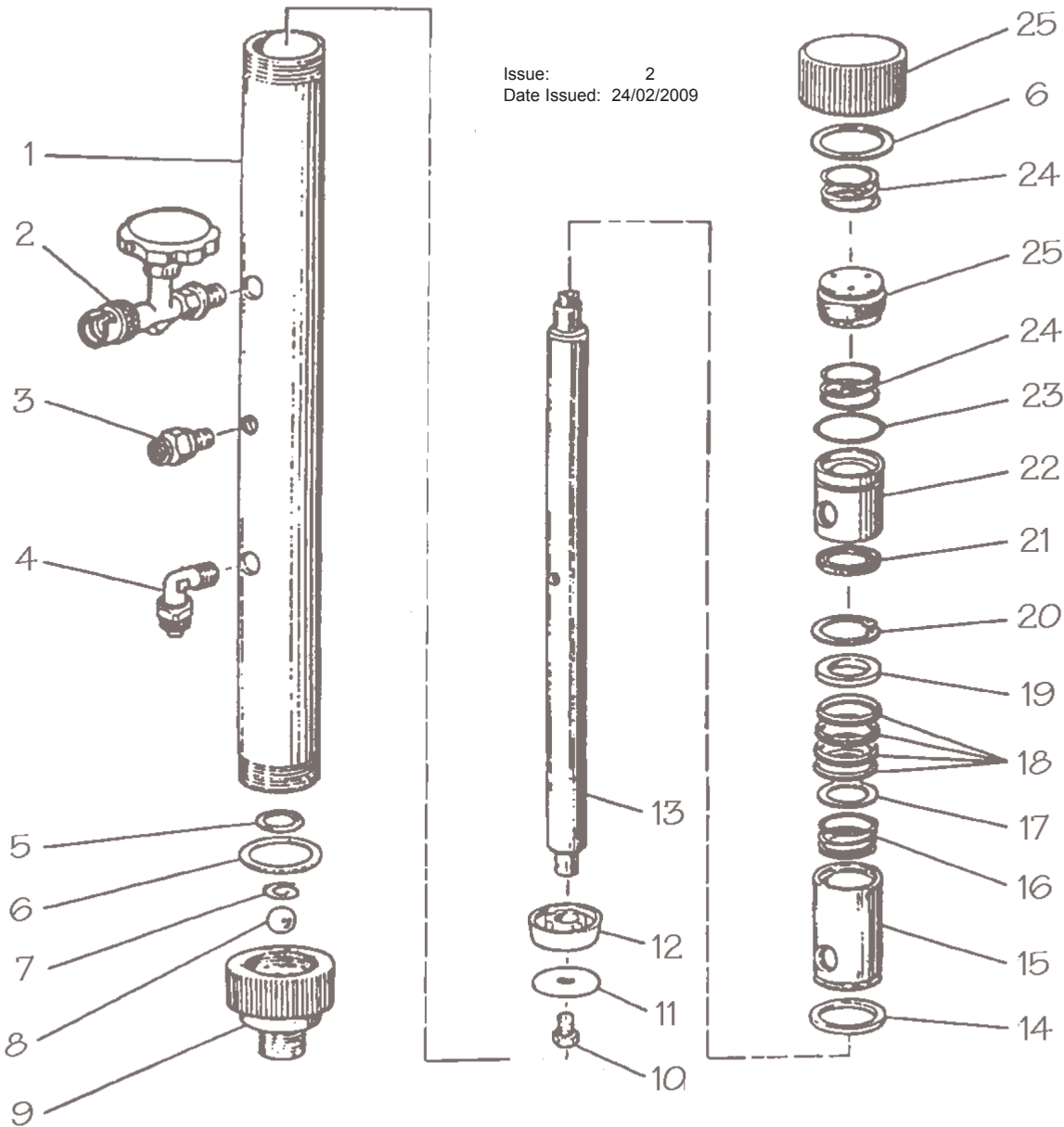

Issue: 2  
Date Issued: 24/02/2009

Item	Part No.	Description	Qty	Item	Part No.	Description	Qty
1	153/18000003N	Pump Housing	1	15	153/18000003M	Gasket Holder	1
2	153/21700010	Air Inlet Valve	1	16	153/18000003W	Spring	1
3	153441A00026	Silencer	1	17	153/18000003J	Metal Washer	1
4	153/18000045	Connector	1	18*	153/18000003D	Gasket	1
5*	153/18000003P	C-Ring, Ø20	1	19*	153/18000003S	Gasket Press Ring	1
6	153/18000003H	Washer	1	20*	153/18000003K	C-Ring, Ø29	1
7	153/18000003O	Standing Valve Spring	1	21*	153/18000003B	Lip Seal	1
8	153/18000003E	Nylon Ball, 1/2.	1	22	153/18000003U	Gasket Holder	1
9	153/18000003L	Standing Valve	1	23*	153/18000003C	Gasket	1
10	153/18000003Y	Screw	1	24	153/18000003T	Upper Spring Cap	1
11	153/18000003Z	Support Washer	1	25*	153/18000003I	Rubber Gasket/Housing	1
12*	153/18000003F	Gasket	1	26	153/18000003X	Pump Cap	1
13	153/18000003Q	Pump Rod	1				
14*	153/18000003G	O-Ring	1				
				*	TP95/RK	Pump Seal Repair Kit	

**NOTE:** It is our policy to continually improve products and as such we reserve the right to alter data, specifications and component parts without prior notice.

**IMPORTANT:** No liability is accepted for incorrect use of product.

**WARRANTY:** Guarantee is 12 months from purchase date, proof of which will be required for any claim.

**INFORMATION:** For a copy of our latest catalogue and promotions call us on 01284 757525 and leave your full name and address, including postcode.