

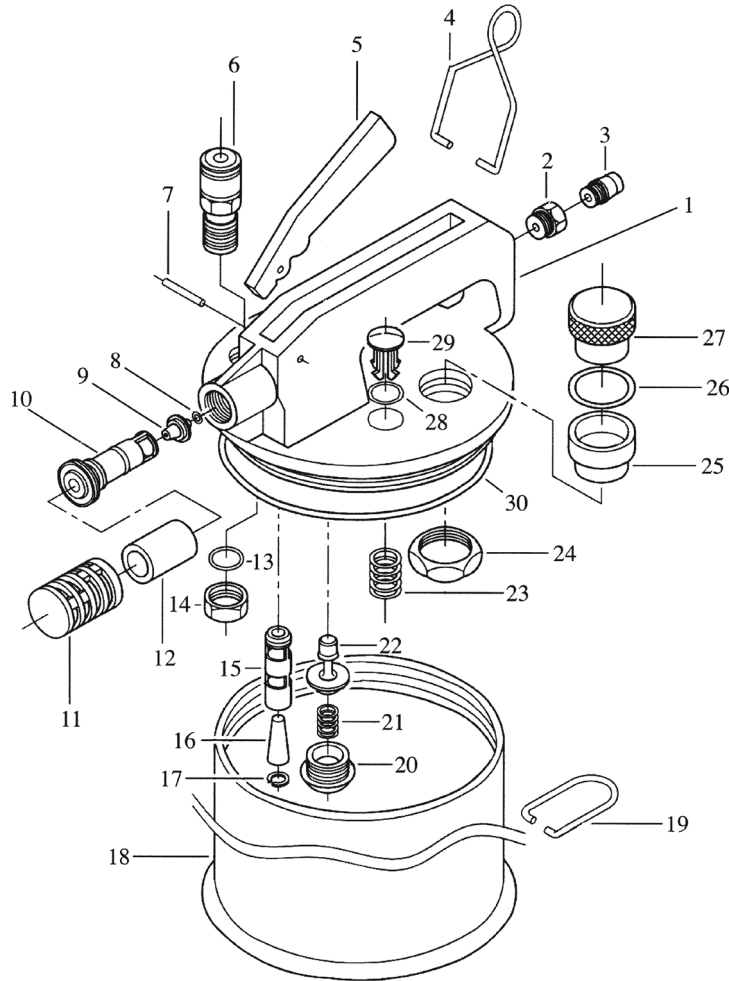

Parts Information:  
**Vacuum Oil & Fluid Extractor Air Operated**  
**5.5ltr**  
**Model No: TP6902**



Item	Part No.	Description
1	TP6902-01	Cover Housing
2	TP6902-02	Inlet Nut
3	TP6902-03	Air Inlet Coupler
4	TP6902-04	Fixing Ring
5	TP6902-05	Trigger
6	TP6902-06	Fluid Inlet Coupler
7	TP6902-07	Pin
8	TP6902-08	O-Ring
9	TP6902-09	Vacuum Valve
10	TP6902-10	Vacuum Body
11	TP6902-11	Noise Reduction Cover
12	TP6902-12	Noise Reduction Net
13	TP6902-13	O-Ring
14	TP6902-14	Lock Nut
15	TP6902-15	Safety Valve
16	TP6902-16	Safety Cup
17	TP6902-17	Circlip

Item	Part No.	Description
18	TP6902-18	Tank
19	TP6902-19	Steady
20	TP6902-20	Locking Screw
21	TP6902-21	Spring
22	TP6902-22	Valve
23	TP6902-23	Spring
24	TP6902-24	Lock Nut
25	TP6902-25	Oil Outlet Housing
26 & 27	TP6902-26	Oil Outlet Cover + O-Ring
28	TP6902-28	O-Ring
29	TP6902-29	Safety Valve
30	TP6902-30	Packing
--	TP6902-V2.32	Nylon Hose, 7.8 x 9.8 OD (NOT SHOWN)
--	TP6902-V2.34	Nylon Hose, 5.3 x 6.7 OD (NOT SHOWN)
--	TP6902-V2.38	Tube, Silicon Rubber (NOT SHOWN)
--	TP6902-34	Guide Wire (NOT SHOWN)

**NOTE:** It is our policy to continually improve products and as such we reserve the right to alter data, specifications and component parts without prior notice.

**IMPORTANT:** No liability is accepted for incorrect use of product.

**WARRANTY:** Guarantee is 12 months from purchase date, proof of which will be required for any claim.

Sealey Group, Kempson Way, Suffolk Business Park, Bury St Edmunds, Suffolk. IP32 7AR



01284 757500



01284 703534



sales@sealey.co.uk



www.sealey.co.uk