

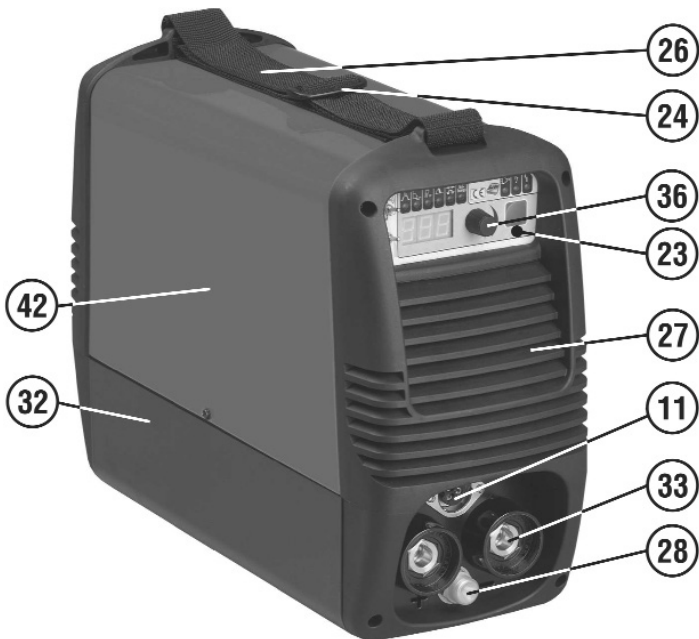

Parts Information:  
Inverter TIG Welder 160Amp AC/DC HF &  
Lift Start  
Model No: TIG175HF

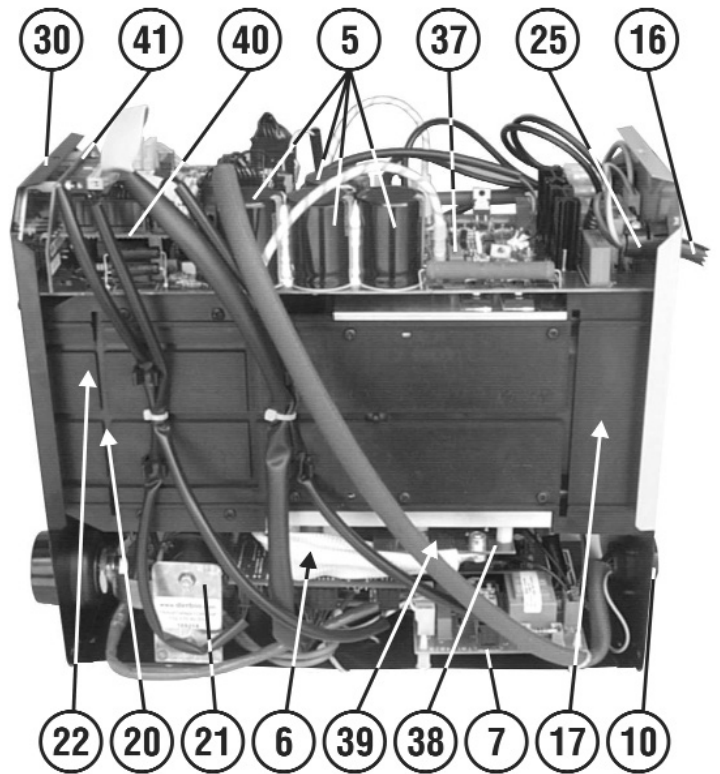
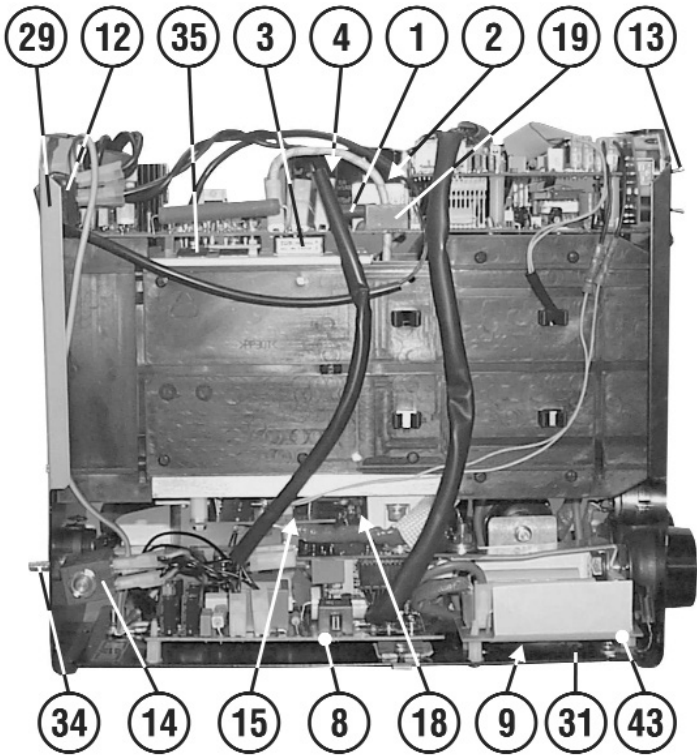

**NOTE:** It is our policy to continually improve products and as such we reserve the right to alter data, specifications and component parts without prior notice.

**IMPORTANT:** No liability is accepted for incorrect use of product.

**WARRANTY:** Guarantee is 12 months from purchase date, proof of which will be required for any claim.

Sealey Group, Kempson Way, Suffolk Business Park, Bury St Edmunds, Suffolk. IP32 7AR



01284 757500



01284 703534



sales@sealey.co.uk



www.sealey.co.uk



Parts Information:  
**Inverter TIG Welder 160Amp AC/DC HF & Lift Start**  
**Model No: TIG175HF**

Item	Part No.	Description
1	120/112048	Resistor
2	120/112342	Relay
3	120/112357	Rectifier
4	120/112513	Varistor
5	120/112514	Capacitor 470uf 400V 50x35
6	120/113585	SCR
7	120/114028	Torch Pushbutton Card
8	120.114381	H.F Card
9	120/120176	Capacitor
10	120.120513	Control Cable
11	120.120514	Socket Cable
12	120.121007	Switch
13	120.121104	Switch
14	120/122035	Electro-Valve 230V
15	120.121128	Thermostat
16	120/132158	Mains Cable
17	120/152214	Fan
18	120/152219	Shunt
19	120/152230	Transformer
20	120.169213	Power Transformer
21	120.169215	HF Transformer
22	120.169227	Inductance
23	120.313768	Front Panel
24	120/322065	Buckle
25	120.322112	Bushing
26	120/322408	Belt
27	120.322508	Frame
28	120/602052	Fitting, Ext Gas Pipe (120/gh)
29	120.638620	Back Panel
30	120.644884	Front Panel
31	120.644885	Bottom

Item	Part No.	Description
31	120.644886	Bottom
33	120/712036	Dinse Socket
34	120/990120	Coupler, Gas Hose
35	120.990729	Kit Diodes-igbt
36	120.990661	Kit Knob
37	120.990727	Primary Kit
38	120.990728	Secondary Kit
39	120.990729	Kit Diodes-igbt
40	120.990730	Control Board Kit
41	120.990731	Panel Kit
42	120.990826	Cover Kit
43	120.990764	Kit Support Control PCB
--	INV/TIG/1	Tig Welding Accessory Kit tg175hf (NOT SHOWN)
--	INV/25	Inverter Arc Welding Kit 25mm <sup>2</sup> (NOT SHOWN)
--	INV/TIG/5	Tig Welder Foot Pedal Power Control (NOT SHOWN)
--	INV/TIG/7	Tig Welder Power Control (NOT SHOWN)
--	090123	Electrode Tungsten 1.6 Green (NOT SHOWN)
--	090133	Electrode Tungs/Thor 1.6 Red (NOT SHOWN)
--	1106	Electrode Tungs/Thor 1.6 Red (NOT SHOWN)
--	090134	Electrode Tungs/Thor 2.4 Red (NOT SHOWN)
--	090163	Electrode Tungs/Zirc 1.6 White (NOT SHOWN)
--	090164	Electrode Tungs/Zirc 2.4 White (NOT SHOWN)
--	090193	Electrode Tungs/Cer 1.6 Grey (NOT SHOWN)
--	090194	Electrode Tungs/Cer 2.4 Grey (NOT SHOWN)
--	120.801081	MMA Welding Kit 300a 25mmq 4+3m dx 50 (NOT SHOWN)
--	120.742424	Tig Torch dwt-17 4Mtr 180a Complete (NOT SHOWN)
--	120.802627	Tig Welding Accessory Kit tg175hf (NOT SHOWN)

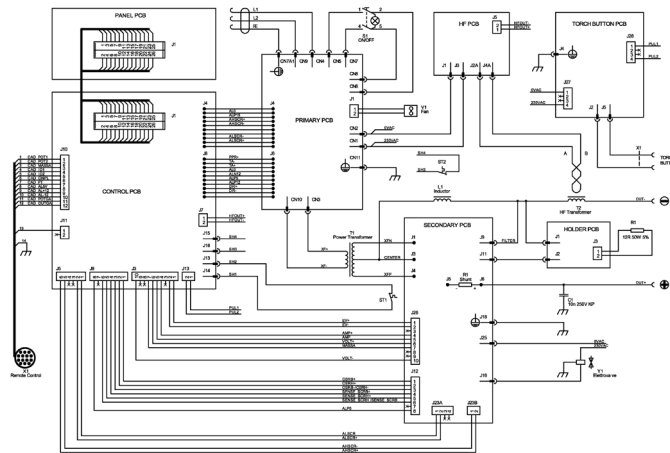

**NOTE:** It is our policy to continually improve products and as such we reserve the right to alter data, specifications and component parts without prior notice.

**IMPORTANT:** No liability is accepted for incorrect use of product.

**WARRANTY:** Guarantee is 12 months from purchase date, proof of which will be required for any claim.

**Sealey Group**, Kempson Way, Suffolk Business Park, Bury St Edmunds, Suffolk. IP32 7AR



01284 757500



01284 703534



sales@sealey.co.uk



www.sealey.co.uk