

ITEM	PART NO	DESCRIPTION
1	168/500170	TORCH BODY STANDARD
2	168/500346	LONG BLACK CAP
3	168/500670	COLLET 2.4MM
4	168/500666	COLLET 1.6MM
5	168/500770	COLLET BODY 2.4MM
6	168/500766	COLLET BODY 1.6MM
7	168/500524	CERAMIC CUP 9.5MM (10N48)
8	168/500364	O-RING
9	168/500408	REAR HEAD INSERT
10	168/500402	HEAT SHIELD FOR COLLET BODY
11	168/501600	HANDLE COMPLETE SB

13. CIRCUIT SCHEMATIC

- Mains input (single phase), rectifier unit and condenser.
- Transistors and drivers switching bridge (IGBT). Turns the mains rectified voltage into high frequency alternating voltage (32kHz) and permits power regulation according to the current / Voltage of weld to be done.
- High frequency transformer: The primary windings are fed by the voltage converted by Block 2, it has the function of adapting voltage and current to values required by the ARC welding procedure and, simultaneously, isolates the welding circuit from mains.
- Secondary rectifier bridge with inductance. Changes the alternating voltage/current supplied by secondary windings into continuous current/voltage at a low wavelength.
- Transistor switching bridge (IGBT) and driver. It transforms the output current to the secondary circuit from DC to AC for AC TIG welding.
- Regulation and control electronics. Controls instantly the value of welding current transistors and compares it with the value set by the operator and modulates the drive impulses of the IGBTs' drivers which execute the regulation.
- Machine operation control logic. Sets up the welding cycles, controls the actuators and monitors the safety systems
- Display, parameter setting and running modes panel.
- HF striking generator.
- Electrovalve for gas protection.
- Machine intelligent cooling fan.
- Remote regulation.

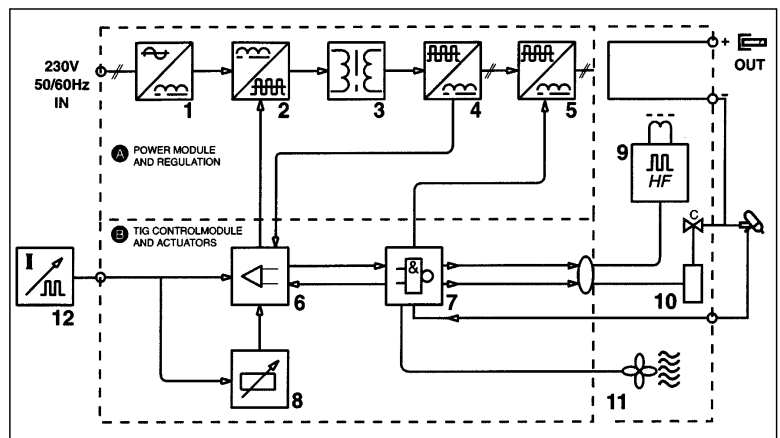

INVERTER

PARTS LISTING FOR :

MODEL : **TIG170/HF**

Issue Date:- 181001
Issue No :- 1

ITEM	PART NO	DESCRIPTION
1	120/114201	BOX HF TYPE C
2	120/990044	KIT PRIMARY PCB
3	120/990048	KIT SECONDARY PCB
4	120/313599	FRONT PANEL CARD
5	120/990077	TIG CONTROL PCB KIT
6	120/120043	CONTROL CABLE
7	120/122050	SECONDARY CABLE
9	120/122035	ELECTRO-VALVE
10	120/122058	KNOB FOR SWITCH
11	120/122444	SWITCH (A 2002)
12	120/132158	MAINS CABLE
13	120/152000	FAN
14	120/990597	AUXILIARY TRANSFORMER
15	120/990623	TRANSFORMER
16	120/169154	HF TRANSFORMER
17	120/164943	INDUCTANCE
18	120/313137	FRONT PANEL ASSEMBLY
19	120/322536	FRAME
20	120/322538	HANDLE
21	120/650119	BOTTOM COVER
22	120/655109	COVER
23	120/712036	DINSE SOCKET
24	120/990026	KNOB KIT
25	120/112357	RECTIFIER
26	120/112048	RESISTOR
27	120/112513	VARISTOR
28	120/112514	CAPACITOR
29	120/112689	DIODE
30	120/112690	IGBT
31	120/112898	RELAY
32	120/112899	DIODE
33	120/112190	FUSE
34	120/122508	THERMAL SWITCH 10.0A
35	120/152219	SHUNT
36	120/152232	PULSE TRANSFORMER
37	120/169088	AUXILIARY TRANSFORMER
38	120/482290	FRONT PANEL
39	120/482691	BACK PANEL
40	120/990120	COUPLER, GAS HOSE
41	120/990046	BUSHING & NUT, CABLE
42	120/990054	KIT IGBT
43	120/602052	FITTING, EXT GAS PIPE (120/GH)
N/S	120/114093	HIGH FREQUENCY CARD (PCB)
N/S	INV/TIG/3	TIG WELDING ACCESSORY KIT

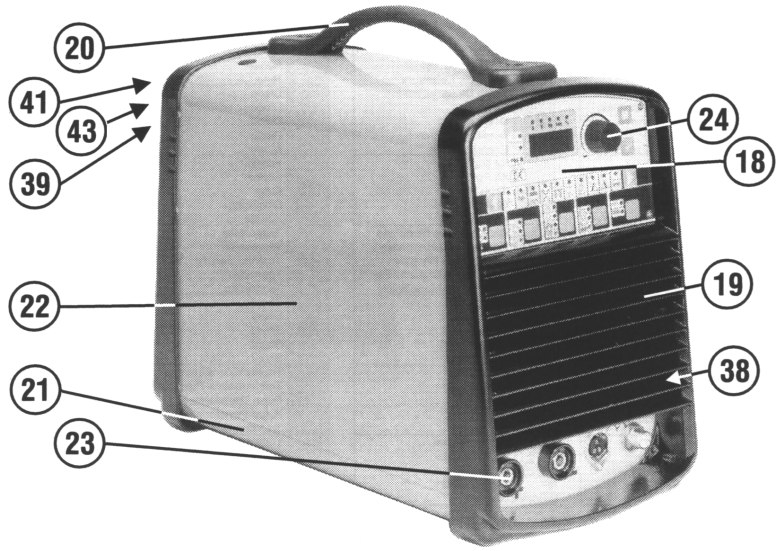

ITEM	PART NO	DESCRIPTION
N/S	090123	ELECTRODE TUNGSTEN 1.6 GREEN
N/S	090133	ELECTRODE TUNGS/THOR 1.6 RED
N/S	090124	ELECTRODE TUNGS/THOR 2.4 RED
N/S	090163	ELECTRODE TUNGS/ZIRC 1.6 WHITE
N/S	090164	ELECTRODE TUNGS/ZIRC 2.4 WHITE
N/S	090193	ELECTRODE TUNGS/CER 1.6 GREY
N/S	090194	ELECTRODE TUNGS/CER 2.4 GREY

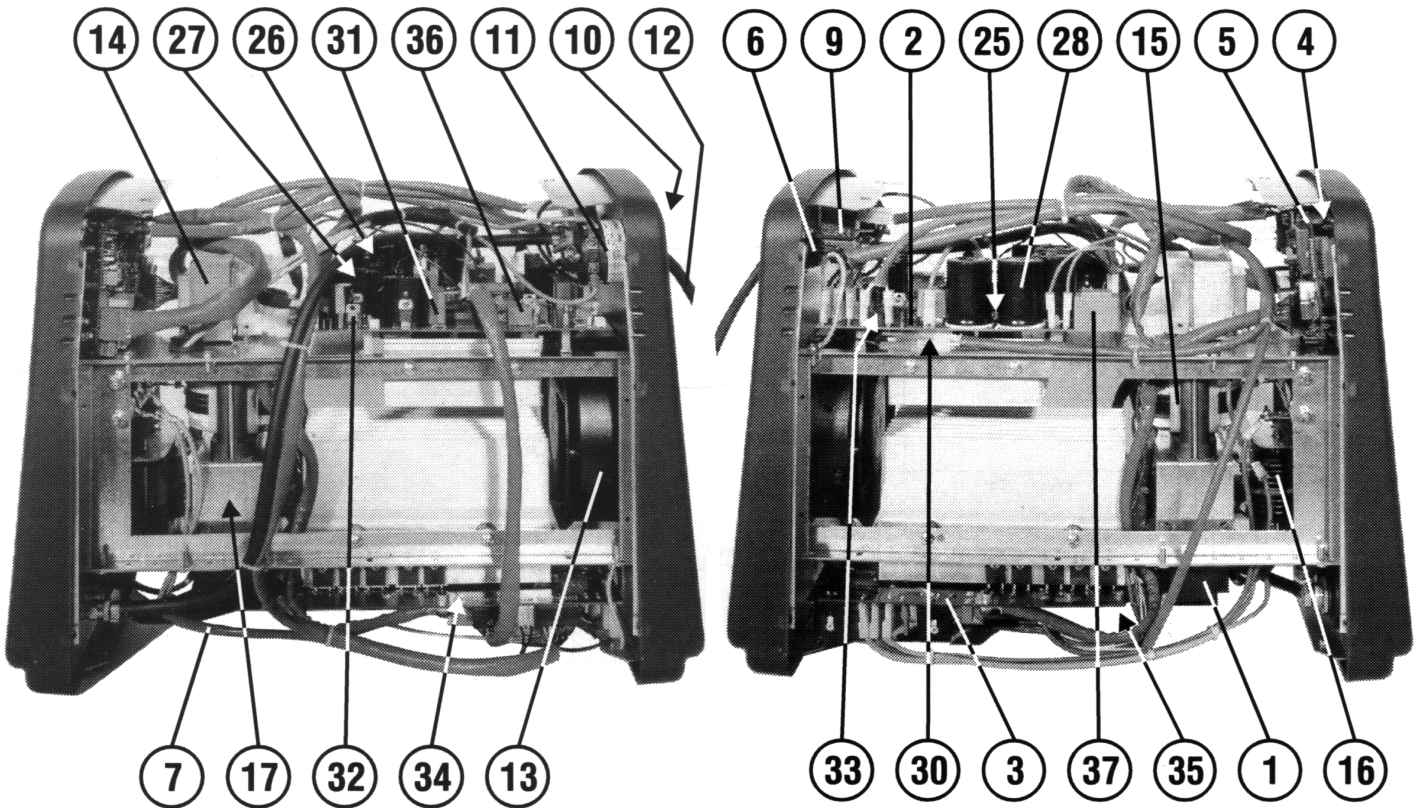

Sole UK Distributor
Sealey Group,
Bury St. Edmunds, Suffolk.

01284 757500

01284 703534

E-mail: sales@sealey.co.uk