

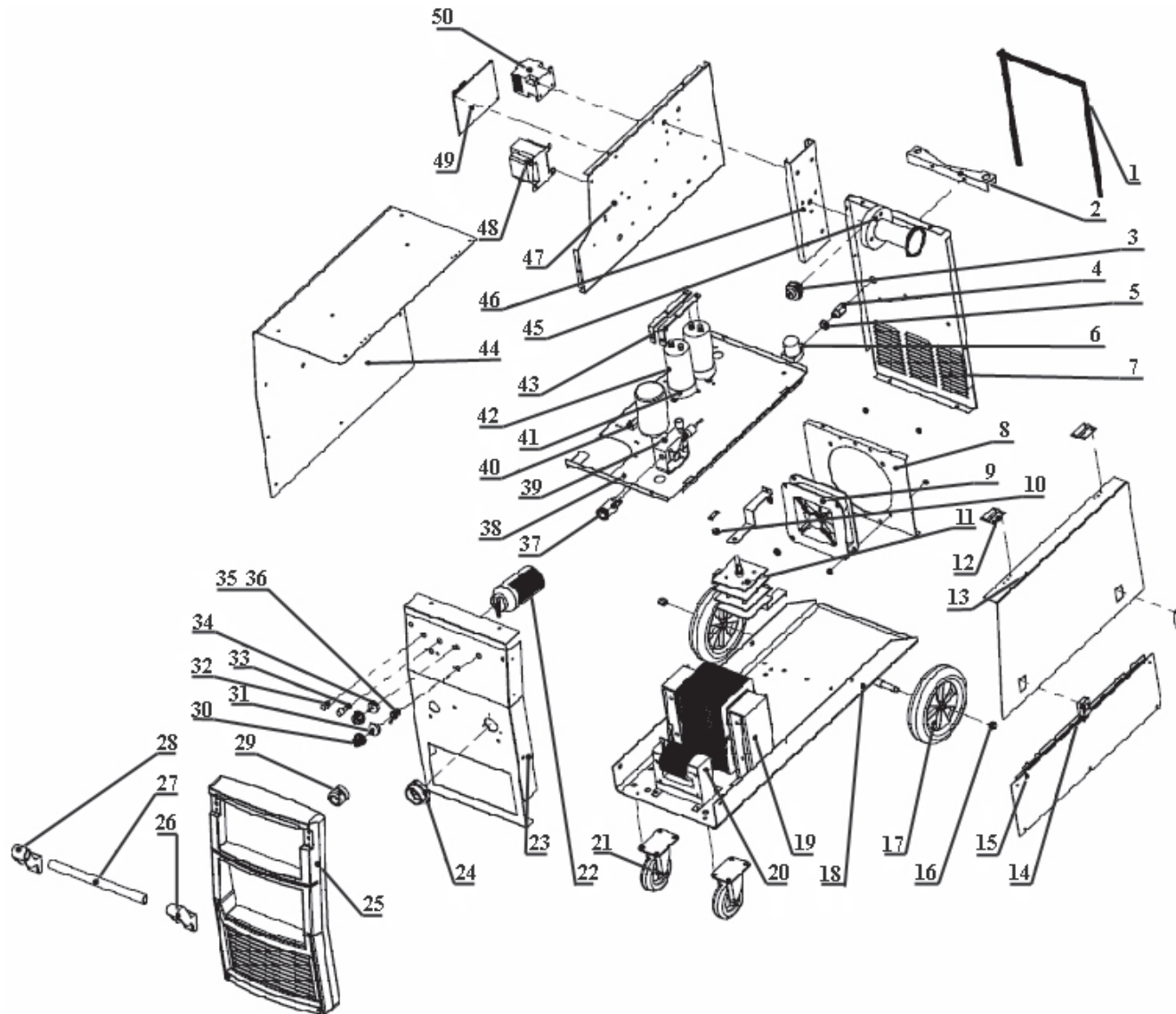

Parts Information:
Professional MIG Welder 250Amp 230V with Binzel® Euro Torch
Model No: SUPERMIG255



Sealey Group, Kempson Way, Suffolk Business Park, Bury St Edmunds, Suffolk. IP32 7AR



01284 757500



01284 703534



sales@sealey.co.uk



www.sealey.co.uk



Parts Information:
**Professional MIG Welder 250Amp 230V
with Binzel® Euro Torch
Model No: SUPERMIG255**

Item	Part No.	Description
1	SMIG275.01	CHAIN
2	SMIG275.02	CYLINDER SUPPORT
3	SMIG275.03	CABLE GLAND
4	SMIG275.04	GAS CONNECTOR
5	SMIG275.05	COPPER NUT
6	SMIG275.06	ELECTRO-VALVE
7	SMIG275.07	REAR PANEL
8	SMIG255.08	FAN MOUNTING PANEL
9	SMIG255.09	FAN
10	SMIG255.10	METAL SUPPORT
11	SMIG255.11	RECTIFIER (SINGLE PHASE)
12	SMIG275.12	PLASTIC HINGE
13	SMIG275.13	UPPER SIDE PANEL, RIGHT
14	SMIG275.14	DOOR LOCK
15	SMIG255.15	LOWER SIDE PANEL, RIGHT
16	SN10.SD	STEEL NUT M10 DOMED (SINGLE)
17	SMIG275.17	WHEEL, FIXED (203x12x43)
18	SMIG255.18	BOTTOM PANEL
19	SMIG255.19	TRANSFORMER
20	SMIG255.20	REACTANCE
21	SMIG275.21	WHEEL, CASTOR (75x15x32x115)
22	SMIG255.22	SWITCH
23	SMIG255.23	FRONT PANEL
24	SMIG275.24	TORCH HOLDER
25	SMIG275.25	FRONT FRAME
26	SMIG275.26	HANDLE SUPPORT, RIGHT
27	SMIG275.27	HANDLE
28	SMIG275.28	HANDLE SUPPORT, LEFT
29	SMIG275.29	QUICK SOCKET 'EU TYPE'
30	PMIG3530.30	POTENTIOMETER KNOB
31	SMIG180.V3-08	POTENTIOMETER (c/w SWITCH)
32	SMIG275.32	INDICATOR LIGHT (GREEN)
33	SMIG275.33	INDICATOR LIGHT (YELLOW)

Item	Part No.	Description
34	SMIG180.V3-06	POTENTIOMETER
35	SMIG275.35	TOGGLE SWITCH
36	PMIG3530.24	GRIP
37	SMIG275.37	COPPER HEAD FOR QUICK SOCKET
38	SMIG275.38	MIDDLE PANEL 'A'
39	PMIG3530.41	DRIVE MOTOR
--	M/MIG210.24A	WIRE FEED ROLLER (0.9-1.0mm) (not shown)
--	SMIG275.52	WIRE FEEDER ROLLER 0.6-0.8mm (not shown)
40	SMIG275.40	RESISTOR
41	SMIG275.41	CLAMP FOR CAPACITOR
42	SMIG255.42	CAPACITOR
43	SMIG275.43	CONNECT BAR
44	SMIG275.44	SIDE PANEL, LEFT
45	SMIG275.45	SPOOL HOLDER
46	SMIG275.46	SPOOL HOLDER SUPPORT
47	SMIG255.47	MIDDLE PANEL 'B'
48	SMIG275.48	CONTROL TRANSFORMER
49	SMIG275.49	MAIN CONTROL BOARD
50	SMIG275.50	AC CONTACTOR
--	M/MIG210.58	MIG TORCH 3mtr EURO CONNECTOR BINZEL TB15 (not shown)
--	REG/MT	MIG GAS REGULATOR 2 GAUGE INDUSTRIAL (not shown)
--	SMIG275.54	THREADED SLEEVE (GAS HOSE CONNECTION) (not shown)
--	SMIG275.55	GAS VALVE CONNECTOR (FOR GAS HOSE) (not shown)
--	SMIG275.54	THREADED SLEEVE (GAS HOSE CONNECTION) (not shown)
--	SMIG275.55	GAS VALVE CONNECTOR (FOR GAS HOSE) (not shown)
--	MIG/GH	HOSE, GAS PER METRE (5mm ID BLACK NYLON HOSE) (not shown)

NOTE: It is our policy to continually improve products and as such we reserve the right to alter data, specifications and component parts without prior notice.

IMPORTANT: No liability is accepted for incorrect use of product.

WARRANTY: Guarantee is 12 months from purchase date, proof of which will be required for any claim.

Sealey Group, Kempson Way, Suffolk Business Park, Bury St Edmunds, Suffolk. IP32 7AR



01284 757500



01284 703534



sales@sealey.co.uk



www.sealey.co.uk