

Original Date: 140400
Issue Date: 1140400
Version No: 0
Date Modified: N/A

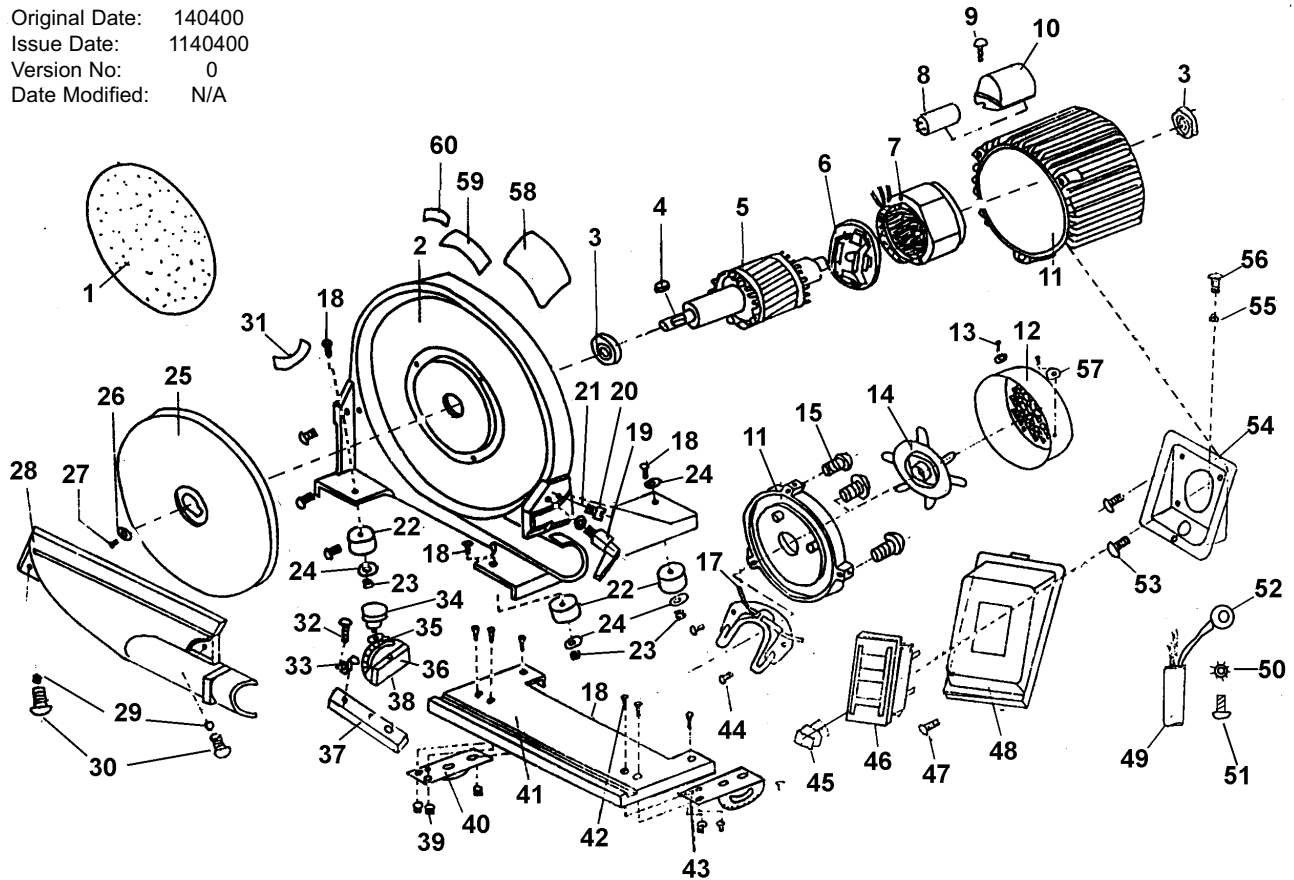

ITEM	PART NO	DESCRIPTION	ITEM	PART NO	DESCRIPTION
1	SM31C/01	SANDING DISC	32	SM31C/32	SCREW M5x6
2	SM31C/02	BASE	33	SM31C/33	M.GAUGE POINTER
3	SM31C/03	BEARING	34	SM31C/34	KNOB BOLT
4	SM31C/04	KEY	35	SM31C/35	BIG FLAT WASHER d6
5	SM31C/05	ROTOR	36	SM31C/36	MITRE GAUGE
6	SM31C/06	CENTRIFUGAL SWITCH	37	SM31C/37	GAUGE SLIDE
7	SM31C/07	STATOR/WINDINGS	38	SM31C/38	PIN 5x12
8	SM31C/08	CAPACITOR	39	SM31C/39	NUT M6
9	SM31C/09	SCREW M4x8	40	SM31C/40	TRUNION (1)
10	SM31C/10	CAPACITOR BOX	41	SM31C/41	WORK TABLE
11	SM31C/11	MOTOR HOUSING	42	SM31C/42	PANHEAD SCREW M6x20
12	SM31C/12	FAN COVER	43	SM31C/43	TRUNION (2)
13	SM31C/13	SCREW M4x8	44	SM31C/44	SCREW M4x6
14	SM31C/14	FAN	45	SM31C/45	SWITCH KEY
15	SM31C/15	SCREW M5x20	46	SM31C/46	SAFETY SWITCH
16	SM31C/16	END BALL	47	SM31C/47	SCREW M4x6
17	SM31C/17	SCREW M6x25	48	SM31C/48	SWITCH PLATE
19	SM31C/19	TABLE LOCK ASSEMBLY	49	SM31C/49	CORD & PLUG
20	SM31C/20	ADJUSTING PIN	50	SM31C/50	TOOTH WASHER d5
21	SM31C/21	FLAT WASHER d6	51	SM31C/51	SCREW M5x10
22	SM31C/22	RUBBER PAD	52	SM31C/52	EARTHING LUG
23	SM31C/23	NUT M6	53	SM31C/53	SCREW M5x10
24	SM31C/24	FLAT WASHER	54	SM31C/54	WIRING BOX
25	SM31C/25	DISC	55	SM31C/55	EARTHING MARK
26	SM31C/26	WASHER	56	SM31C/56	RIVET 2x6
27	SM31C/27	PANHEAD SCREW M6x20	57	SM31C/57	FLAT WASHER d4
28	SM31C/28	DUST CHUTE COVER	58	SM31C/58	NAME PLATE
29	SM31C/29	SPRING WASHER d6	59	SM31C/59	WARNING LABEL
30	SM31C/30	SCREW M6x20	60	SM31C/60	ROTATION ARROW
31	SM31C/31	REFERENCE LABLE			

NOTE: It is our policy to continually improve products and as such we reserve the right to alter data, specifications and component parts without prior notice.



01284 757500



01284 703534

E-mail: sales@sealey.co.uk