

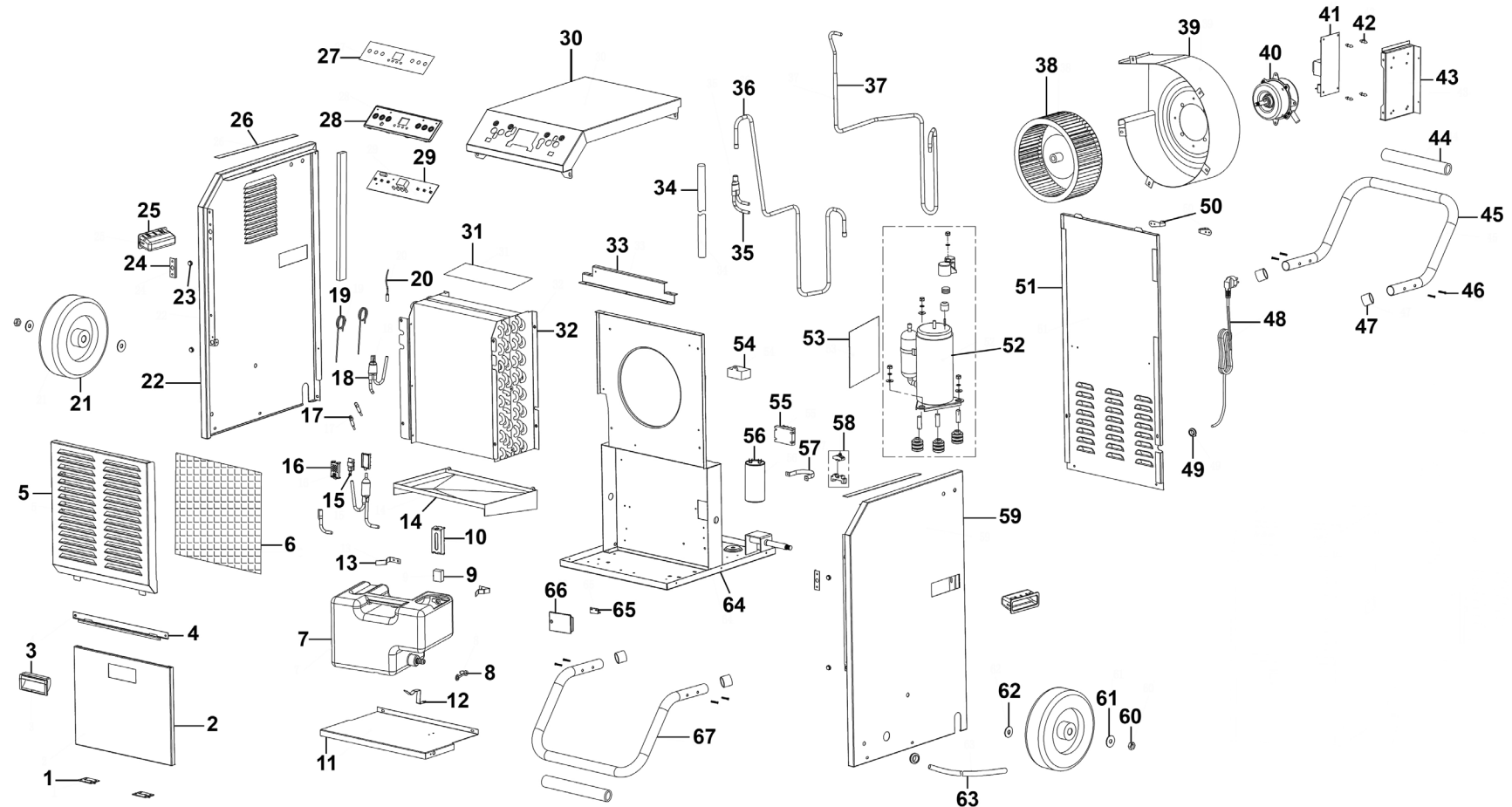

Parts Information:  
**Industrial Dehumidifier 70L**  
**Model No: SDH70.V4**



**NOTE:** It is our policy to continually improve products and as such we reserve the right to alter data, specifications and component parts without prior notice.

There may be alternative versions of this product, please contact us should you require this information.

**IMPORTANT:** No liability is accepted for incorrect use of product. Spare parts must be fitted by a competent person

**WARRANTY:** Guarantee is 12 months from purchase date, proof of which will be required for any claim.

Sealey Group, Kempson Way, Suffolk Business Park, Bury St Edmunds, Suffolk. IP32 7AR



01284 757500



sales@sealey.co.uk



www.sealey.co.uk



Parts Information:  
**Industrial Dehumidifier 70L**  
**Model No: SDH70.V4**

| Item | Part No.    | Description                       | Qty |
|------|-------------|-----------------------------------|-----|
| 1    | SDH70-V4-01 | Magnet (A)                        | 3   |
| 2    | SDH70-V4-02 | Front Panel Lower Cover           | 1   |
| 3    | SDH70-V4-03 | Front Handle Grip                 | 1   |
| 4    | SDH70-V4-04 | Front Support Strip               | 1   |
| 5    | SDH70-V4-05 | Front Panel Upper Cover           | 1   |
| 6    | SDH70-V4-06 | Front Filter                      | 1   |
| 7    | SDH70-V4-07 | Water Tank                        | 1   |
| 8    | SDH70-V4-08 | Water Tank Plug                   | 1   |
| 9    | SDH70-V4-09 | Water Tank Float                  | 1   |
| 10   | SDH70-V4-10 | Float Cover                       | 1   |
| 11   | SDH70-V4-11 | Base Plate                        | 1   |
| 12   | SDH70-V4-12 | Water Tank Bracket (A)            | 1   |
| 13   | SDH70-V4-13 | Water Tank Bracket (B)            | 1   |
| 14   | SDH70-V4-14 | Water Tray                        | 1   |
| 15   | SDH70-V4-15 | Humidity Sensor                   | 1   |
| 16   | SDH70-V4-16 | Front Cover for Humidity Sensor   | 1   |
| 17   | SDH70-V4-17 | Capillary Outlet Tube             | 2   |
| 18   | SDH70-V4-18 | Filter (3-Way)                    | 1   |
| 19   | SDH70-V4-19 | Capillary                         | 2   |
| 20   | SDH70-V4-20 | Temperature Sensor                | 1   |
| 21   | SDH70-V4-21 | Fixed, Plastic Wheel              | 2   |
| 22   | SDH70-V4-22 | Side Panel, Left                  | 1   |
| 23   | SDH70-V4-23 | Magnet (B)                        | 4   |
| 24   | SDH70-V4-24 | Fixed Plate for Magnet            | 2   |
| 25   | SDH70-V4-25 | Side Handle Grip                  | 2   |
| 26   | SDH70-V4-26 | Protection Foam for Side Panel    | 2   |
| 27   | SDH70-V4-27 | Display Key Panel                 | 1   |
| 28   | SDH70-V4-28 | Control Panel                     | 1   |
| 29   | SDH70-V4-29 | Display PCB Board                 | 1   |
| 30   | SDH70-V4-30 | Top Panel                         | 1   |
| 31   | SDH70-V4-31 | Protection Foam for Evaporator    | 1   |
| 32   | SDH70-V4-32 | Evaporator                        | 1   |
| 33   | SDH70-V4-33 | Sealed Plate for Fan              | 1   |
| 34   | SDH70-V4-34 | Protection Foam for Pressure Pipe | 1   |

| Item | Part No.    | Description                         | Qty |
|------|-------------|-------------------------------------|-----|
| 35   | SDH70-V4-35 | Fluid Inlet Tube                    | 1   |
| 36   | SDH70-V4-36 | Pressure Pipe (High)                | 1   |
| 37   | SDH70-V4-37 | Pressure Pipe (Low)                 | 1   |
| 38   | SDH70-V4-38 | Fan                                 | 1   |
| 39   | SDH70-V4-39 | Fan Cover                           | 1   |
| 40   | SDH70-V4-40 | Motor                               | 1   |
| 41   | SDH70-V4-41 | PCB                                 | 1   |
| 42   | SDH70-V4-42 | Support Colum for PCB               | 1   |
| 43   | SDH70-V4-43 | Fixed Bracket for PCB               | 1   |
| 44   | SDH70-V4-44 | Foam Sleeve for Front/Bottom Sleeve | 2   |
| 45   | SDH70-V4-45 | Front/Bottom Frame                  | 1   |
| 46   | SDH70-V4-46 | Screw                               | 8   |
| 47   | SDH70-V4-47 | End Plug                            | 4   |
| 48   | SDH70-V4-48 | Power Cord                          | 1   |
| 49   | SDH70-V4-49 | Power Cord Grip                     | 2   |
| 50   | SDH70-V4-50 | Hanging Clip                        | 2   |
| 51   | SDH70-V4-51 | Rear Panel                          | 1   |
| 52   | SDH70-V4-52 | Compressor                          | 1   |
| 53   | SDH70-V4-53 | Protection Foam for Compressor      | 1   |
| 54   | SDH70-V4-54 | Motor Capacitor                     | 1   |
| 55   | SDH70-V4-55 | Control Terminal                    | 1   |
| 56   | SDH70-V4-56 | Capacitor for Compressor            | 1   |
| 57   | SDH70-V4-57 | Capacitor Clip                      | 1   |
| 58   | SDH70-V4-58 | Wire Block Complete                 | 1   |
| 59   | SDH70-V4-59 | Side Panel, Right                   | 1   |
| 60   | SDH70-V4-60 | Nut                                 | 2   |
| 61   | SDH70-V4-61 | Washer                              | 2   |
| 62   | SDH70-V4-62 | Spring Washer                       | 2   |
| 63   | SDH70-V4-63 | Outlet Pipe                         | 1   |
| 64   | SDH70-V4-64 | Base                                | 1   |
| 65   | SDH70-V4-65 | Lock Button                         | 1   |
| 66   | SDH70-V4-66 | Backing Plate                       | 1   |
| 67   | SDH70-V4-67 | Front/Bottom Frame                  | 1   |

**NOTE:** It is our policy to continually improve products and as such we reserve the right to alter data, specifications and component parts without prior notice. There may be alternative versions of this product, please contact us should you require this information.

**IMPORTANT:** No liability is accepted for incorrect use of product. Spare parts must be fitted by a competent person

**WARRANTY:** Guarantee is 12 months from purchase date, proof of which will be required for any claim.

Sealey Group, Kempson Way, Suffolk Business Park, Bury St Edmunds, Suffolk. IP32 7AR



01284 757500



sales@sealey.co.uk



www.sealey.co.uk