

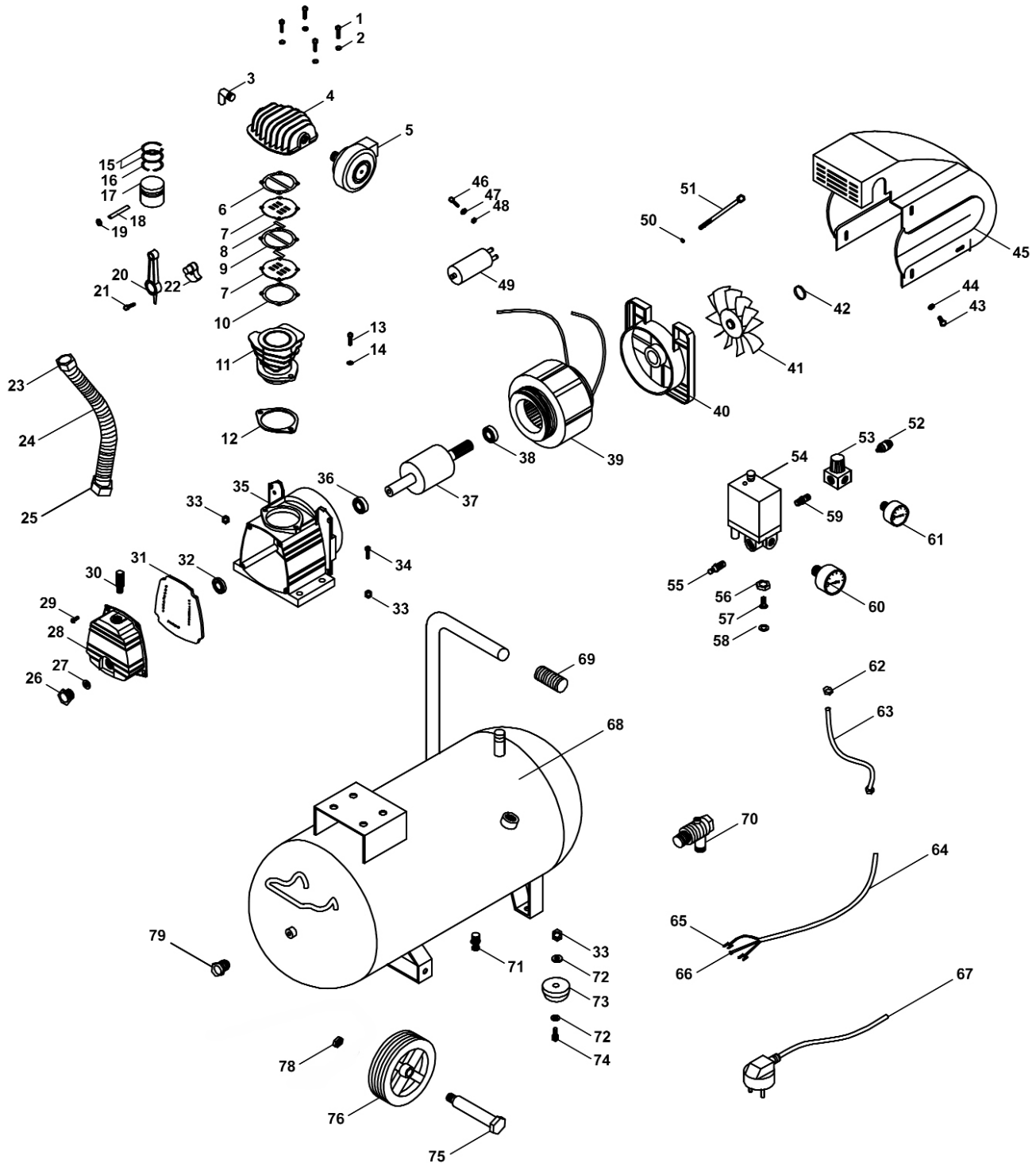

Parts Information:
Compressor 24ltr Direct Drive 2hp 110V
Model No: SAC2420E110V



NOTE: It is our policy to continually improve products and as such we reserve the right to alter data, specifications and component parts without prior notice.

IMPORTANT: No liability is accepted for incorrect use of product.

WARRANTY: Guarantee is 12 months from purchase date, proof of which will be required for any claim.

Sealey Group, Kempson Way, Suffolk Business Park, Bury St Edmunds, Suffolk. IP32 7AR



01284 757500



01284 703534



sales@sealey.co.uk



www.sealey.co.uk



Parts Information:
Compressor 24ltr Direct Drive 2hp 110V
Model No: SAC2420E110V

1	SAC5020E.01	HEAD BOLT (M6*55)
2	SWM6.S	SPRING WASHER M6 ZINC (SINGLE)
3	SAC0610EV2.22	ELBOW 3/8"M x 3/8"M
4	SA22503.04	CYLINDER HEAD
5	SAC5030VE2.30	AIR FILTER
6	SAC2420EV2.24	CYLINDER HEAD GASKET
7	SAC5020E.07	VALVE PLATE
8	SA22503.08	VALVE
9	SAC5030VE.09	VALVE GASKET
10	SAC5030VE.10	CYLINDER GASKET
11	SAC5020E.11	CYLINDER
12	SAC5020E.12	CYLINDER GASKET
13	SAC5020E.13	BOLT
14	SAC5020E.14	SPRING WASHER
15	SAC5020E.15	COMPRESSION RING
16	SAC5020E.15	COMPRESSION RING
17	SAC5030VE.17	PISTON
18	SAC5020E.18	SPRING PIN
19	SAC5020E.19	CIRCLIP
20	SAC5020E.20	CONNECTING ROD
21	SA2250-V2.21	SOCKET CAP BOLT BLACK M8X20
22	SAC5020E.22	CRANK SHAFT
23	SAC5020E.23	NUT
24	SAC5020E.24	EXHAUST PIPE
25	SAC5020E.24	EXHAUST PIPE
26	SA2225-V3.27	OIL SIGHT GLASS RING
27	SA2225-V3.27	OIL SIGHT GLASS RING
28	SA2250-V2.28	FRONT CAP
29	SFS616.S	HEX HEAD FLANGE BOLT M6x16 SINGLE
30	SAC3103B.P44	BREATHER
31	SAC5020E.31	GASKET
32	SA2250-V2.32	SHAFT SEAL (20x40x7)
33	SN8.S	STEEL NUT M8 ZINC DIN934 (SINGLE)
34	SAC5020E.34	BOLT (M8*45)
35	SA2250-V2.35	CRANKCASE
36	B/6204-2RS	BEARING 6204-2RS
37	SAC5020E.37	ROTOR
38	B/6202-2RS	BEARING 6202-2RS
39	SAC5020E.39A	STATOR (110V)
40	SAC5020E.40	REAR COVER

Item	Part No.	Description
41	SA2225-V2.63	FAN
42	SAC5020E.42	FAN RING
43	SAC5020E.43	BOLT (M5*12)
44	SAC5020E.44	WASHER
45	SAC5020E.45	PUMP HOUSING
46	SAC5020E.46	BOLT (M3*6)
47	SAC5020E.47	WASHER
48	SAC5020E.48	SPRING WASHER
49	SAC5020E.49A	CAPACITOR
50	SAC5020E.50	SPRING WASHER
51	SAC5020E.51	BOLT M5X100
52	SAC5030VE.79	AIR VALVE
53	SAC5030VE.80	REGULATOR
54	SA2225-V3.58	PRESSURE SWITCH 15Amp 12 Bar 175psi
55	SAC5020E.55	SAFETY VALVE
56	SAC5020E.56	NUT M16x1.50 FINE PITCH
57	SAC5020E.57	CONNECTOR
58	SAC5020E.58	WASHER
59	SAC5030VE.82	CONNECTOR
60	SAC0610E.55	PRESSURE GAUGE (d.50),0-200psi,rear fit
61	SAC5020E.61	GAUGE 200psi, 40mm OD, REAR MOUNTING
62	SAC5020E.62	UNLOADING SCREW NUT
63	SAC2420E.63	UNLOADING PIPE
64	SAC5020E.64	ELECTRIC CABLE
65	SAC5020E.65	CABLE CONNECTOR (U)
66	SAC5020E.66	CABLE CONNECTOR (O)
67	SAC5020E.67A	POWER LEAD (110V)
68	SAC2420E.68	TANK 24ltr
69	SAC0610E.63	HANDLE GRIP
70	SAC5020E.70	CHECK VALVE
71	SAC5030VE.75	DRAIN VALVE
72	SAC5020E.72	WASHER
73	SAC5020E.73	RUBBER FOOT
74	SS825.S	HEX HEAD SET SCREW M8x25mm SINGLE
75	SAC5030VE.74	WHEEL SHAFT (c/w NUT & WASHER)
76	SAC5030VE.73	WHEEL, FIXED (150x13x34)
78	SN10.S	STEEL NUT M10 ZINC DIN934(SINGLE)
79	SAC5030VE.76	TANK PLUG

NOTE: It is our policy to continually improve products and as such we reserve the right to alter data, specifications and component parts without prior notice.

IMPORTANT: No liability is accepted for incorrect use of product.

WARRANTY: Guarantee is 12 months from purchase date, proof of which will be required for any claim.

Sealey Group, Kempson Way, Suffolk Business Park, Bury St Edmunds, Suffolk. IP32 7AR



01284 757500



01284 703534



sales@sealey.co.uk



www.sealey.co.uk