

PARTS LIST FOR: AIR OPERATED PINSTRIPE REMOVING TOOL Model: SA95

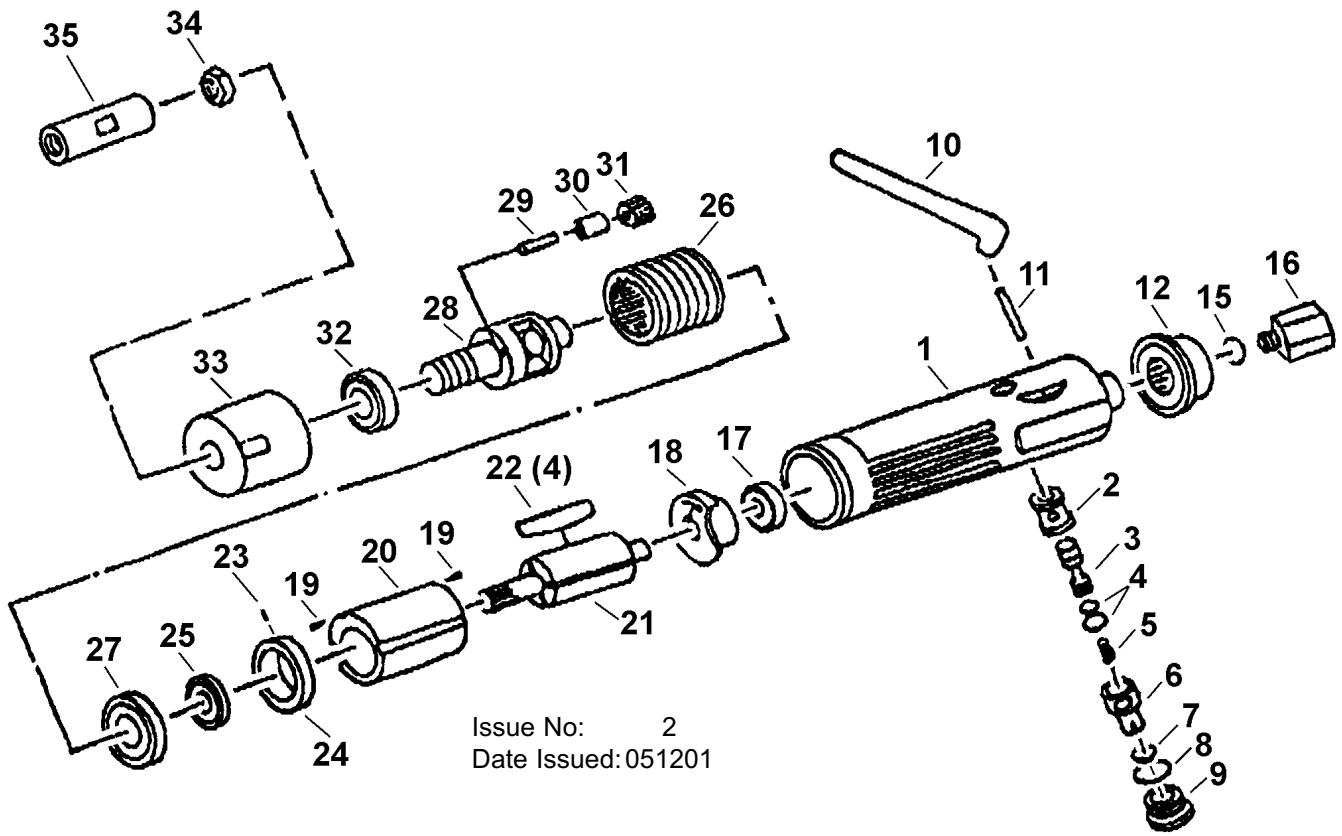

Issue No: 2
Date Issued: 051201

Item	Part No.	Description	Item	Part No.	Description
1	SA95F/01	Motor Housing	20	SA95F/20	Cylinder
2	SA95F/02	Valve Bushing	21	SA95F/21	Rotor
3	SA95F/03	Valve Stem	22	SA95F/22	Rotor Blade
4	SA95F/04	O-ring	23	SA95F/23	Roll Pin
5	SA95F/05	Spring	24	SA95F/24	Front End Plate
6	SA95F/06	Air Regulator	25	B/608ZZ	Bearing
7	SA95F/07	O-ring	26	SA95F/26	Internal Gear
8	SA95F/08	O-ring	27	B/6001ZZ	Bearing
9	SA95F/09	Valve Screw	28	SA95F/28	Planet Cage
10	SA95F/10	Throttle Lever	29	SA95F/29	Planet Pin
11	SA95F/11	Lever Pin	30	SA95F/30	Idle Gear Bushing
12	SA95F/12	Exhaust Sleeve	31	SA95F/31	Planet Gear
15	SA95F/15	O-ring	32	B/626ZZ	Bearing
16	SA95F/16	Inlet Bushing	33	SA95F/33	Housing Cap
17	B/6000ZZ	Bearing	34	SA95F/34	Nut
18	SA95F/18	Rear End Plate	35	SA95F/35	Body
19	SA95F/19	Motor Pin			

NOTE: It is our policy to continually improve products and as such we reserve the right to alter data, specifications and component parts without prior notice. **IMPORTANT:** No liability is accepted for incorrect use of this equipment. **WARRANTY:** Guarantee is 12 months from purchase date, proof of which will be required for any claim. **INFORMATION:** For a copy of our latest catalogue and promotions call us on 01284 757525 and leave your full name and address, including postcode.