

Item	Part No.	Description
1	SH56510390	Upper Cover (New Type)
2	SH56510320	Lower Cover (New Type)
3	SH9420171	Pressure Switch (C/W Reg) 16Amp 12Bar 175psi
--	SH30700048	Tank 10Ltr (NOT SHOWN)
4	SH51912000	Tank 10Ltr (New Type)
--	SH15300310	Drain Valve 1/4" (NOT SHOWN)
6	SH56510580	Drain Valve (New Type)
7	SH59110010	Spring (New Type)
8	SH36507080	Return Valve (New Type)

Item	Part No.	Description
9	SH56910280	1/2" Connection(New)5mm Thick
10	SH50510320	Rubber Gasket (New Type)
--	SH00400103	Screw (NOT SHOWN)
11	SH57310620	Screw (New Type)
--	SH00200111	Pressure Switch Pipe (NOT SHOWN)
12	SH54310400	Pressure Switch Pipe (New Type)
--	SH00200126	Rubber Foot (NOT SHOWN)
13	SH56510160	Rubber Foot (New Type)

NOTE: It is our policy to continually improve products and as such we reserve the right to alter data, specifications and component parts without prior notice.
IMPORTANT: No liability is accepted for incorrect use of product.
WARRANTY: Guarantee is 12 months from purchase date, proof of which will be required for any claim.

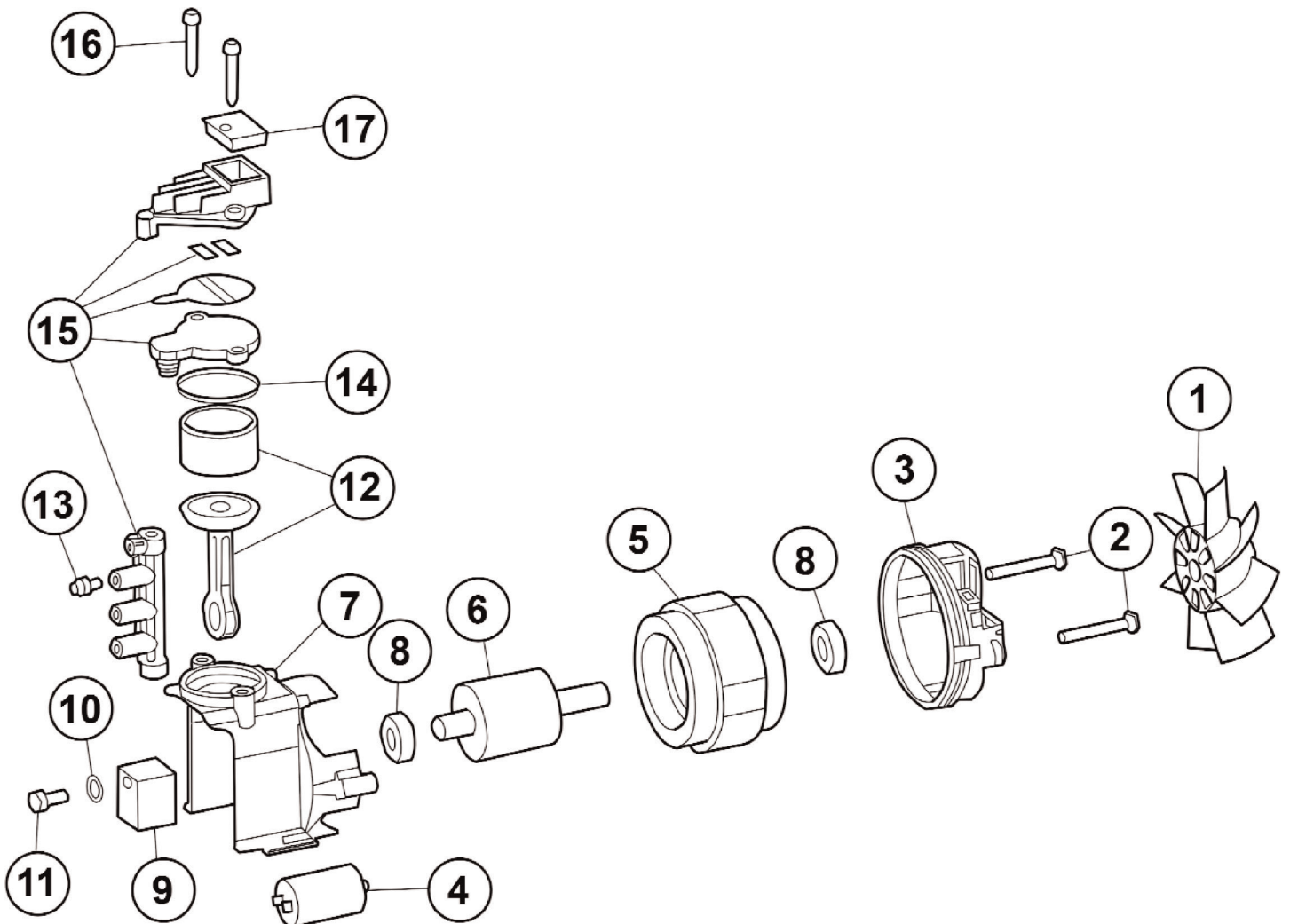

Item	Part No.	Description
--	SH00200103	Fan (NOT SHOWN)
1	SH51010110	Fan (New Type)
2	SH00400102	Head Screw
3	SH50410060	Back Cover (New Type)
4	SH59210050	Capacitor 20uf 430/400V 70x45
5	SH53311080	Stator 2 Core Cable
--	SH00300041P	Rotor (NOT SHOWN)
6	SH53311060	Rotor (New Type)
7	SH00100110	Body Cylinder
--	B/6004-2RS	Bearing 6004-2RS (NOT SHOWN)
8	SH50310140	Bearing (New Type)
--	SH00500107	Balance Weight (NOT SHOWN)

Item	Part No.	Description
9	SH50210010	Balance Weight
10	FWM10.S	Flat Washer M10 Single
--	SH00400229	Wrist Pin (NOT SHOWN)
11	SH57310240	Wrist Pin (New Type) see cm
--	SH001001131	Connecting Rod & Cylinder (NOT SHOWN)
12	SH52510700	Con Rod And Cyl Liner
13	SH56910050	1/4" Pressure Connector
14	SH50510460	Head Gasket (New Type)
15	SH52510170	Valve Plate Kit (New Type)
16	SH00400102	Head Screw
--	SH00200186	Filter Cover (NOT SHOWN)
17	SH50410020	Filter Cover

NOTE: It is our policy to continually improve products and as such we reserve the right to alter data, specifications and component parts without prior notice.

IMPORTANT: No liability is accepted for incorrect use of product.

WARRANTY: Guarantee is 12 months from purchase date, proof of which will be required for any claim.