

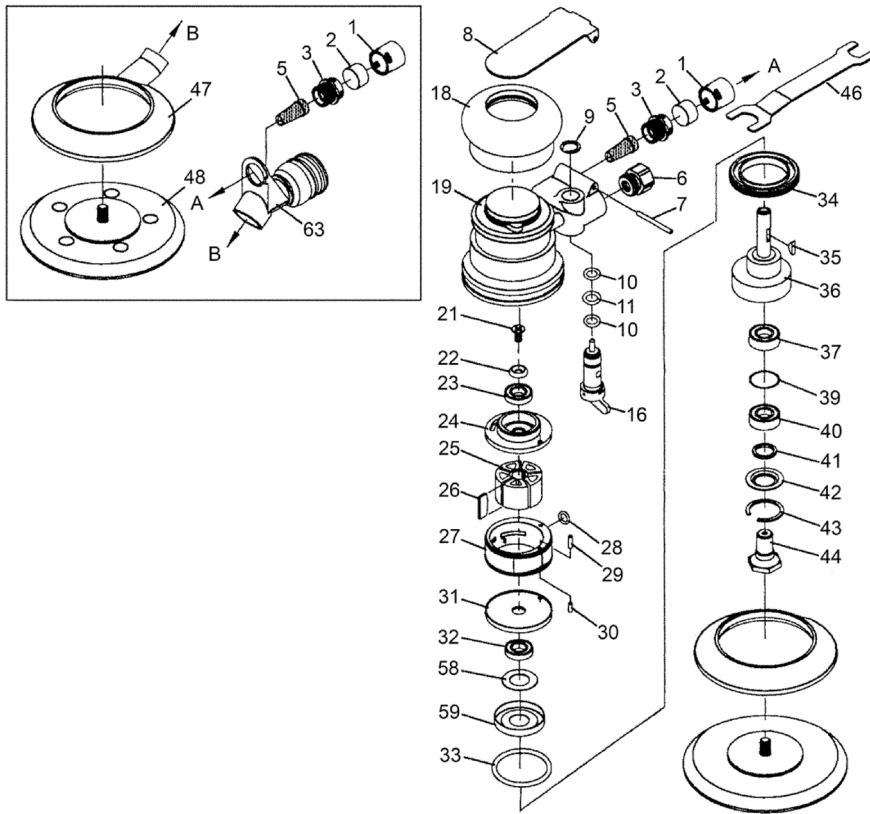

Parts Information:
Air Palm Sander 150mm Dust-Free
Model No: SA801.V2



Item	Part No.	Description
1	SA800.V2/01	Cover
2	SA800.V2-02	Felt
3	SA800.V2-03	Muffer Body
5	SA800.V2-05	Cone Muffer
6	SA800.V2-06	Inlet Bushing
7	SA800.V2-07	Spring Pin
8	SA800.V2-08	Lever
9	SA800.V2-09	Snap Ring
10	SA800.V2-10	O-Ring
11	SA800.V2-11	O-Ring
16	SA800.V2-16	Regulator Assembly
18	SA800.V2-18	Rubber Cover
19	SA800.V2-19	Housing
21	SA800.V2-21	Flat Screw
22	SA800.V2-22	Washer
23	B/6000ZZ	Bearing 6000ZZ
24	SA800.V2-24	Rear Plate
25	SA800.V2-25	Rotor
26	SA800.V2-26	Rotor Blade
27	SA800.V2-27	Cylinder
28	SA800.V2-28	O-Ring
29	SA800.V2-29	Spring Pin

Item	Part No.	Description
30	SA800.V2-30	Spring Pin
31	SA800.V2-31	Front Plate
32	B/6000ZZ	Bearing 6000ZZ
33	SA800.V2-33	O-Ring
34	SA800.V2-34	Guard Bushing
35	SA800.V2-35	Rotor Key
36	SA800.V2-36	Shaft Balancer, 6" Pad
37	B/6001	Bearing 6001
39	SA800.V2-39	Washer
40	B/6001-RS	Bearing 6001-RS
41	SA800.V2/41	Felt Ring
42	SA800.V2/42	Bearing Shield
43	SA800.V2-43	Snap Ring
44	SA800.V2-44	Shaft
46	SA800.V2-46	Spanner
47	SA801.V2-47	Shroud
48	AK290	Universal Dust-Free Hook/Loop DA Backing Pad 150mmx 5/16"UNF
58	SA800.V2-58	Washer
59	SA801.V2-59	Safeguard Bushing
63	SA801.V2-63	Vacuum Adaptor
--	AK289	Univ Dust-Free Stick-On DA Backing Pad 150mm x 5/16"UNF & M8 (NOT SHOWN)

NOTE: It is our policy to continually improve products and as such we reserve the right to alter data, specifications and component parts without prior notice.

IMPORTANT: No liability is accepted for incorrect use of product.

WARRANTY: Guarantee is 12 months from purchase date, proof of which will be required for any claim.

Sealey Group, Kempson Way, Suffolk Business Park, Bury St Edmunds, Suffolk. IP32 7AR



01284 757500



01284 703534



sales@sealey.co.uk



www.sealey.co.uk