

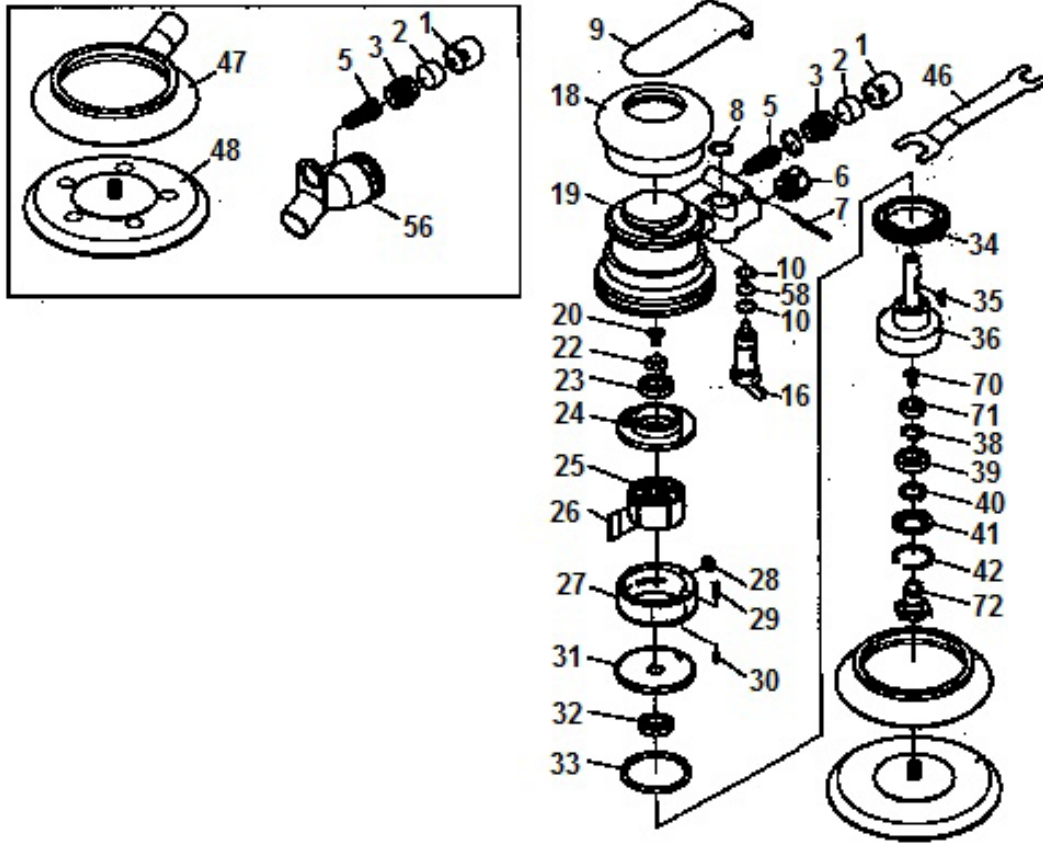

Parts Information:  
**Air Palm Sander 6" Dust-Free**  
**Model No: SA801**



Item	Part No.	Description
1	SA800.V2/01	Cover
2	SA800.V2-02	Felt
3	SA800.V2-03	Muffler Body
5	SA800.V2-05	Cone Muffler
6	SA800.V2-06	Inlet Bushing
7	SA800.V2-07	Spring Pin
8	SA800.V2-08	Lever
9	SA800.V2-09	Ext Circlip 14mm OD.
10	SA800.V2-10	O-Ring
16	SA800.16	Regulator Assembly
18	SA800.V2-18	Rubber Cover
19	SA800.V2-19	Housing
20	SA800.V2-21	Flat Screw
22	SA800.V2-22	Washer
23	B/6000ZZ	Bearing 6000ZZ
24	SA800.24	Rear Plate
25	SA800.25	Rotor
26	SA800.V2-26	Rotor Blade
27 - 30	SA800.A	Cylinder Assembly
31	SA800.V2-31	Front Plate

Item	Part No.	Description
32	B/6000ZZ	Bearing 6000ZZ
33	SA800.33	O-Ring
34	SA800.V2-34	Guard Bushing
35	SA800.V2-35	Rotor Key
36	SA800.36	Motor Shaft Balancer
38	SA800.38	Snap Ring
39	B/6001-2RS	Bearing 6001-2RS
40	SA800.V2/41	Felt Ring
41	SA800.V2/42	Bearing Shield
42	SA800.V2-43	Snap Ring
46	SA800.V2-46	Spanner
47	SA801.V2-47	Shroud
48	AK290	Universal Dust-Free Hook/Loop DA Backing Pad 150mmx 5/16"UNF
56	SA801.56	Vacuum Adaptor
58	SA800.58	O-Ring
70	SA800.70	Screw
71	SA800.71	Bearing
72	SA800.72	Shaft
--	AK289	Univ Dust-Free Stick-On DA Backing Pad 150mm x 5/16"UNF & M8 (NOT SHOWN)

**NOTE:** It is our policy to continually improve products and as such we reserve the right to alter data, specifications and component parts without prior notice.

**IMPORTANT:** No liability is accepted for incorrect use of product.

**WARRANTY:** Guarantee is 12 months from purchase date, proof of which will be required for any claim.

**Sealey Group**, Kempson Way, Suffolk Business Park, Bury St Edmunds, Suffolk. IP32 7AR



01284 757500



01284 703534



sales@sealey.co.uk



www.sealey.co.uk