



INSTRUCTIONS FOR AIR OPERATED STAPLER

Model: SA78X

Thank you for purchasing a Sealey Product. Manufactured to a high standard this product will, if used according to these instructions and properly maintained, give you years of trouble free performance.

IMPORTANT: PLEASE READ THESE INSTRUCTIONS CAREFULLY. NOTE THE SAFE OPERATIONAL REQUIREMENTS, WARNINGS AND CAUTIONS. USE THIS PRODUCT CORRECTLY AND WITH CARE FOR THE PURPOSE FOR WHICH IT IS INTENDED. FAILURE TO DO SO MAY CAUSE DAMAGE AND/OR PERSONAL INJURY AND WILL INVALIDATE THE WARRANTY. PLEASE KEEP INSTRUCTIONS SAFE FOR FUTURE USE.

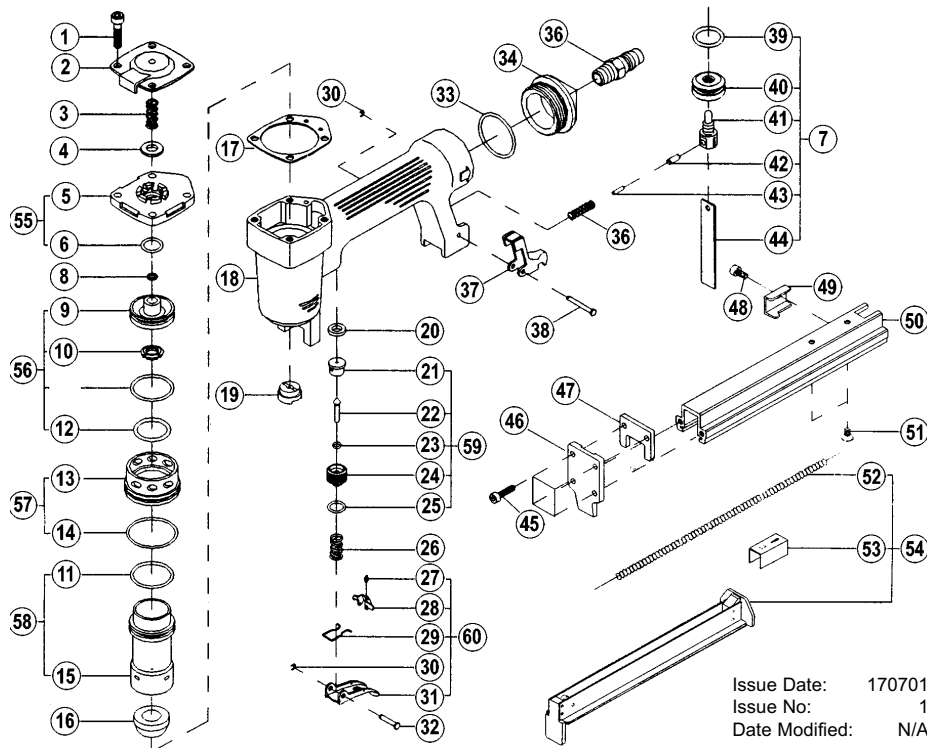

Issue Date: 170701
Issue No: 1
Date Modified: N/A

ITEM	PART NO.	DESCRIPTION	ITEM	PART NO.	DESCRIPTION
1	SA78X/01	SCREW 5*22	31	SA78X/31	TRIGGER
2	SA78X/02	EXHAUST COVER	32	SA78X/32	STEP PIN 5*17.5
3	SA78X/03	COMPRESSION SPRING	33	SA78X/33	O-RING 31.42*2.62
4	SA78X/04	SEAL,AIR	34	SA78X/34	TAIL COVER
5	SA78X/05	CYLINDER CAP	35	SA78X/35	AIR PLUG
6	SA78X/06	O-RING 11.8*2.4	36	SA78X/36	COMPRESSION SPRING
7	SA78X/07	PISTON SET	37	SA78X/37	CLICK LEVER
8	SA78X/08	WASHER 7.3*4.7*0.8	38	SA78X/38	STEP PIN 5*26
9	SA78X/09	HEAD VALVE PISTON	39	SA78X/39	O-RING 17.3*3
10	SA78X/10	PISTON STOPPER	40	SA78X/40	PISTON HEAD
11	SA78X/11	O-RING 26.6*2.4	41	SA78X/41	DRIVER BLADE PIN
12	SA78X/12	O-RING 21.3*3	42	SA78X/42	OUTER SPRING PIN 4*10
13	SA78X/13	COLLAR	43	SA78X/43	INNER SPRING PIN 2.5*10
14	SA78X/14	O-RING 33*2	44	SA78X/44	DRIVER BLADE
15	SA78X/15	CYLINDER	45	SA78X/45	SCREW 4*16
16	SA78X/16	BUMPER	46	SA78X/46	DRIVER GUIDE
17	SA78X/17	GASKET	47	SA78X/47	SPACER
18	SA78X/18	BODY	48	SA78X/48	SCREW 4*8
19	SA78X/19	NOZZLE	49	SA78X/49	STOPPER
20	SA78X/20	SEAL,AIR	50	SA78X/50	UPPER MAG
21	SA78X/21	TRIGGER VALVE HEAD	51	SA78X/51	SCREW 4*8
22	SA78X/22	TRIGGER VALVE STEM	52	SA78X/52	EXTENSION SPRING
23	SA78X/23	O-RING 3.8*1.5	53	SA78X/53	PUSHER
24	SA78X/24	TRIGGER VALVE GUIDE	54	SA78X/54	MAGAZINE ASSEMBLY
25	SA78X/25	O-RING 9.8*1.9	55	SA78X/55	CYLINDER CAP SET
26	SA78X/26	COMPRESSION SPRING	56	SA78X/56	HEAD VALVE PISTON SET
27	SA78X/27	TRIGGER SPRING	57	SA78X/57	COLLAR SET
28	SA78X/28	TRIGGER STOPPER	58	SA78X/58	CYLINDER ASSEMBLY
29	SA78X/29	HOLDER SPRING	59	SA78X/59	TRIGGER VALVE SET
30	SA78X/30	E-RING 2.5 DIAM	60	SA78X/60	TRIGGER SET

1. SAFETY INSTRUCTIONS

- ⚠ **WARNING!** Ensure Health & Safety, local authority, and general workshop practice regulations are adhered to when using this equipment.
- ⚠ **WARNING!** Disconnect from air supply before refilling with staples, servicing or performing maintenance.
- 3 Maintain the stapler in good condition (use an authorised service agent).
- 3 Replace or repair damaged parts. Use genuine parts only. Non-authorized parts may be dangerous and will invalidate the warranty.
- 3 Use in suitable clean and tidy working area, free from unrelated materials and ensure there is adequate lighting.
- ⚠ **WARNING!** Always wear approved eye or face and hand protection when operating the stapler
- 3 Remove ill fitting clothing. Remove ties, loose jewellery, and contain and/or tie back long hair.
- 3 Wear appropriate protective clothing and keep hands and body clear of working parts.
- 3 Maintain correct balance and footing. Ensure the floor is not slippery and wear non-slip shoes.
- 3 Keep children and unauthorised persons away from the working area.
- 3 Check moving parts alignment on a regular basis.
- 3 Ensure workpiece is secure before operating the stapler. Never hold a workpiece by hand.
- 3 Avoid unintentional operation by always engaging the trigger safety catch when not in use or during pauses in operation.
- ⚠ **WARNING!** Ensure correct air pressure is maintained and not exceeded. Recommended pressure 50-90psi.
- 3 Keep air hose away from heat, oil and sharp edges. Check air hose for wear before each use and ensure that all connections are secure.
- 3 Prolonged exposure to vibration from this stapler poses a health risk. It is the Employer's/Owners and operator's responsibility to correctly assess the potential hazard and issue guidelines for safe periods of use and offer suitable protective equipment.
- 7 DO NOT point the staple discharge outlet at yourself or anyone else.
- 7 DO NOT use any power source except an air compressor.
- 7 DO NOT operate the stapler near any inflammable substance or on any container that once contained an inflammable substance.
- 7 DO NOT use the stapler for a task it is not designed to perform.
- 7 DO NOT operate stapler if any parts are damaged or missing as this may cause failure and/or personal injury.
- 7 DO NOT carry the stapler by the hose, or yank the hose from the air supply.
- 7 DO NOT place the stapler close to your face and do not point at other persons or animals.
- 7 DO NOT operate stapler when you are tired, under the influence of alcohol, drugs or intoxicating medication.
- 7 DO NOT carry the stapler with your finger on the trigger.
- 7 DO NOT direct air from the air hose at yourself or others.
- 3 When not in use engage the trigger safety catch, disconnect from air supply and store in a safe, dry, childproof location.

NOTE: It is our policy to continually improve products and as such we reserve the right to alter data, specifications and component parts without prior notice. **IMPORTANT:** No liability is accepted for incorrect use of this equipment. **WARRANTY:** Guarantee is 12 months from purchase date, proof of which will be required for any claim. **INFORMATION:** Call us for a copy of our latest catalogue and promotions on 01284 757525 and leave your full name and address including your postcode.



Sole UK Distributor, Sealey Group, Bury St. Edmunds, Suffolk.



01284 757500



01284 703534

E-mail: sales@sealey.co.uk

2. INTRODUCTION & SPECIFICATION

The SA78X is a light weight well balanced stapler suitable for stapling a wide variety of materials including woods, plastics and fabrics. It has a rubber comfort grip and trigger safety catch. The kit supplied includes a starter pack of staples, goggles, hex keys and air tool oil. A carrying case is supplied.

SPECIFICATION		Staples available in packs of 5000 (20 gauge).		
	Part No.	Crown.	Length	
Capacity6,8,10,12,14mm 20 gauge staples	SA-AS/06	12.8	6mm	
Operating Pressure50 - 90psi	SA-AS/08	12.8	8mm	
Air Consumption4cfm	SA-AS/10	12.8	10mm	
Air Inlet1/4" BSP	SA-AS/12	12.8	12mm	
Weight0.8kg	SA-AS/14	12.8	14mm	

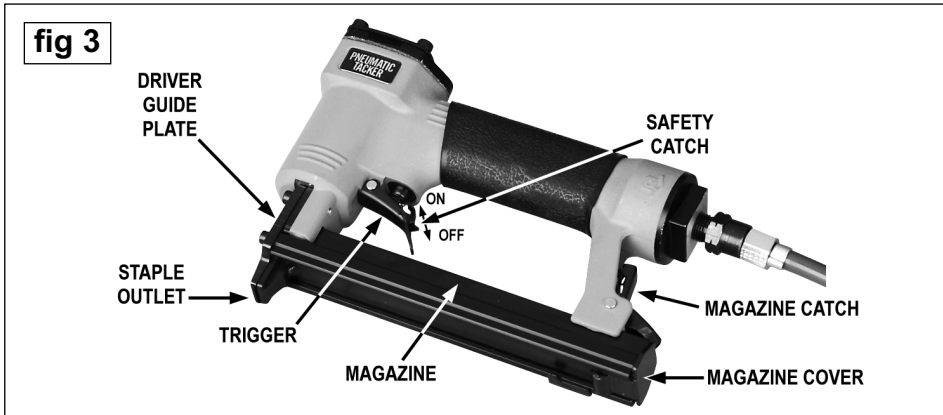

3. PREPARING STAPLER FOR USE

3.1. Air Supply

- 3.1.1. Ensure the safety catch on the air valve trigger is in place before connecting to the air supply.
- 3.1.2. You will require an air pressure between 50-90psi, and an air flow according to the specification above.
- 3.1.3. **WARNING!** Ensure the air supply is clean and does not exceed 90 psi while operating the stapler. Too high an air pressure and unclean air will shorten the product life due to excessive wear, and may be dangerous causing damage and/or personal injury.
- 3.1.4. Drain the air tank daily. Water in the air line will damage the stapler **and will invalidate your warranty.**
- 3.1.5. Clean air inlet filter weekly. Recommended hook-up procedure is shown in fig 1.
- 3.1.6. Line pressure should be increased to compensate for unusually long air hoses (over 8 metres). The minimum hose diameter should be 1/4" I.D. and fittings must have the same inside dimensions.
- 3.1.7. Keep hose away from heat, oil and sharp edges. Check hoses for wear, and make certain that all connections are secure.

3.2. Couplings.

Vibration may cause failure if a quick change coupling is connected directly to the air stapler. To overcome this, connect a leader hose to the stapler. A quick change coupling may then be used to connect the leader hose to the air line recoil hose. See fig 1 & 2.

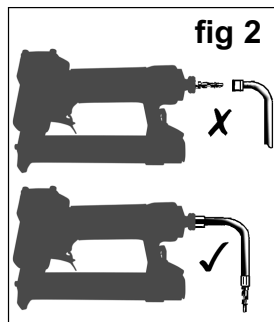
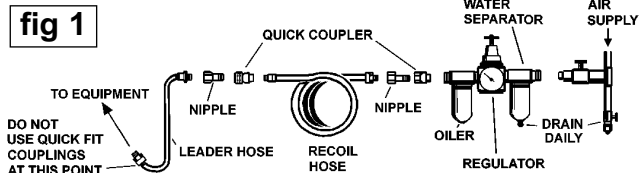

4. OPERATING INSTRUCTIONS

- WARNING! Ensure you read, understand and apply safety instructions before use.**
- 4.1 Before connecting to an air line ensure that the safety catch on the trigger is engaged by pivoting it towards the stapler body. (See fig.3)
 - 4.2 Load the magazine with staples before connecting the airline. To load the staples press and hold open the magazine catch (situated below the air inlet) and slide open the magazine cover to its full extent. Place a batch of staples into the open magazine chamber with the staple legs facing outwards.
 - 4.3 Slide the magazine cover shut until it clicks into place behind the catch. As you do this the internal spring will start to bear onto the batch of staples holding them in place ready for stapling.
 - 4.4 Connect the air line to the stapler as described in Section 3.
 - 4.5 Bring the stapler to the workpiece and when ready to commence stapling pivot the trigger safety catch towards the end of the trigger to release it. Ensure that the staple outlet is pressed flat onto the material to be stapled and is at approximately 90° to the surface.
 - 4.6 When the trigger is depressed a single staple will be fired. To fire the next staple release the trigger and depress again. Repeat as required.
 - 4.7 When the work is complete or when you have paused, engage the safety catch to prevent accidental discharge of staples.

5. MAINTENANCE

- WARNING!** Disconnect stapler from air supply before refilling with staples, servicing or performing maintenance. Replace damaged parts.
Use genuine parts only. Non-authorized parts may be dangerous and will invalidate the warranty.
- 5.1. Lubricate the air stapler daily with a few drops of the air tool oil supplied, dripped into the air inlet before use. (To re-order air tool oil use Sealey part Nos. ATO/500 or ATO1000.)
 - 5.2. Clean the stapler after use and engage safety catch.
 - 5.3. Loss of power or erratic action may be due to the following:
 - a) Excessive drain on the air line. Moisture or restriction in the air pipe. Incorrect size or type of hose connectors. To remedy check the air supply and follow instructions in chapter 3.
 - b) Grit or gum deposits in the stapler may also reduce performance. If your model has an air strainer (located in the area of the air inlet), remove the strainer and clean it. Flush the stapler out with gum solvent oil or an equal mixture of SAE No 10 oil and kerosene. Allow to dry before use.
 If you continue to experience problems, contact your local Sealey service agent.
 - 5.4. For a full service contact your local Sealey service agent.
 - 5.5. When not in use, disconnect from air supply, clean stapler and store in a safe, dry, childproof location.
 - 5.6. On a weekly basis check the security of the hex bolts holding the driver guide plate in place and tighten if necessary. (see fig.3)

Declaration of Conformity

CE We, the sole importer into the UK, declare that the product listed here is in conformity with the following EEC standards and directives. The construction file for this product is held by the Manufacturer and may be inspected, by a national authority, upon request to Jack Sealey Ltd.

**Air Operated Stapler
Model: SA78X**

98/37/EC Machinery Directive
93/68/EEC Marking Directive

Signed by Mark Sweetman

17th July 2001

For Jack Sealey Ltd. Sole importer into the UK of Sealey Power Products.