

SEALEY POWER PRODUCTS

SEALEY POWER PRODUCTS

INSTRUCTIONS FOR

AIR OPERATED RANDOM ORBITAL SANDER

Model: **SA7/S**

Thank you for purchasing a Sealey Product. Manufactured to a high standard this product will, if used according to these instructions and properly maintained, give you years of trouble free performance.

IMPORTANT: PLEASE READ THESE INSTRUCTIONS CAREFULLY. NOTE THE SAFE OPERATIONAL REQUIREMENTS, WARNINGS AND CAUTIONS. USE THIS PRODUCT CORRECTLY AND WITH CARE FOR THE PURPOSE FOR WHICH IT IS INTENDED. FAILURE TO DO SO MAY CAUSE DAMAGE OR PERSONAL INJURY AND WILL INVALIDATE THE WARRANTY. PLEASE KEEP INSTRUCTIONS SAFE FOR FUTURE USE.

1. SAFETY INSTRUCTIONS

- ⚠ **WARNING!** Ensure Health & Safety, local authority, and general workshop practice regulations are adhered to when using this equipment.
- ⚠ **WARNING!** Disconnect from air supply before changing accessories or servicing.
- 3 Maintain the sander in good condition (use an authorised service agent).
- 3 Replace or repair damaged parts. Use genuine parts only. Non-authorized parts may be dangerous and will invalidate the warranty.
- 3 Use in suitable clean and tidy working area, free from unrelated materials and ensure there is adequate lighting.
- 3 Before each use check abrasive pads for condition. If worn or damaged replace immediately.
- 3 Ensure the abrasive pad rating is the same as, or, greater than the RPM rating of the sander.
- 3 Ensure there are no flammable or combustible materials near the work area.
- ⚠ **WARNING!** Always wear approved eye or face and hand protection when operating the sander.
- 3 Use face, dust, or respiratory protection in accordance with COSHH regulations.
- 3 Depending on the task, sander noise level may exceed 85dB in which case wear safety ear defenders.
- 3 Remove ill fitting clothing. Remove ties, watches, rings, other loose jewellery, and contain and/or tie back long hair.
- 3 Wear appropriate protective clothing and keep hands and body clear of working parts.
- 3 Maintain correct balance and footing. Ensure the floor is not slippery and wear non-slip shoes.
- 3 Keep children and unauthorised persons away from the working area.
- 3 Check moving parts alignment on a regular basis.
- 3 Ensure workpiece is secure before operating the sander. Never hold a workpiece by hand.
- 3 Check the workpiece to ensure there are no protruding screws, bolts, nuts, nails, stones, etc.
- 3 Avoid unintentional starting.
- ⚠ **WARNING!** Ensure correct air pressure is maintained and not exceeded. Recommended pressure 70-90psi
- 3 Keep air hose away from heat, oil and sharp edges. Check air hose for wear before each use and ensure that all connections are secure.
- 3 Prolonged exposure to vibration from this sander poses a health risk. It is the operator's responsibility to correctly assess the potential hazard and issue guidelines for safe periods of use and offer suitable protective equipment.
- 7 DO NOT use the sander for a task it is not designed to perform.
- 7 DO NOT operate sander if any parts are damaged or missing as this may cause failure and/or personal injury.
- 7 DO NOT use cloth backed sanding pads. Use only appropriate paper adhesive pads, following pad instructions.
- ⚠ **WARNING!** DO NOT sand any materials containing asbestos.
- 7 DO NOT carry the sander by the hose, or yank the hose from the air supply.
- 7 DO NOT force, or apply heavy pressure to the sander, let the sander do the work.
- 7 DO NOT place attachments close to your face and do not point at other persons or animals.
- 7 DO NOT operate sander when you are tired, under the influence of alcohol, drugs or intoxicating medication.
- 7 DO NOT use sander where there is flammable liquids, solids or gases such as paint solvents and including waste wiping or cleaning rags etc.
- 7 DO NOT carry the sander with your finger on the power lever.
- 7 DO NOT direct air from the air hose at yourself or others.
- 3 When not in use disconnect from air supply and store in a safe, dry, childproof location.

Item	Part No	Description	Item	Part No	Description
1	SA7S/01	SCREW	27	SA7S/27	RETAINING RING
2	SA7S/02	FLAT WASHER	28	SA7S/28	CAP SCREW (S)
3	SA7S/03	WASHER WAVE	29	SA7S/29	CAP SCREW (L)
4	SA7S/04	SPINDLE LOCK	30	SA7S/30	RIVE HOUSING
5	SA7S/05	SPACER	31	SA7S/31	GASKET
6	SA7S/06	WAVE WASHER	32	SA7S/32	MOTOR HOUSING
7	SA7S/07	HEX. NUT	33	SA7S/33	HOUSING COVER
9	SA7S/09	RETAINING RING	34	SA7S/34	VALVE-SPEED REGULATOR
10	SA7S/10	WAVE WASHER	35	SA7S/35	O-RING
11	SA7S/11	DRIVE SPINDLE	36	SA7S/36	RING RETAINING
12	SA7S/12	USE B/6201ZZ BEARING	37	SA7S/37	THROTTLE VALVE SPRING
13	SA7S/13	WASHER WAVE	38	SA7S/38	O-RING
14	SA7S/14	FONT SCREW	39	SA7S/39	VALVE STEM
15	SA7S/15	ORBITAL HUB	40	SA7S/40	O-RING
16	SA7S/16	SOCKET SCREW	41	SA7S/41	O-RING
17	SA7S/17	ROTOR SHAFT	42	SA7S/42	VALVE BODY
18	SA7S/18	KEY	43	SA7S/43	BRACKET
19	SA7S/19	WAVE WASHER	44	SA7S/44	HINGE SCREW
20	SA7S/20	USE B/6200Z BEARING	45	SA7S/45	HEX. NUT
21	SA7S/21	END PLATE	46	SA7S/46	LOCK WASHER
22	SA7S/22	ROTOR	47	SA7S/47	HEX. NUT
23	SA7S/23	ROTOR BLADE [9mm]	48	SA7S/48	THROTTLE LEVER
24	SA7S/24	CYLINDER	49	SA7S/49	HANDING COVER
25	SA7S/25	LOCATING PIN	50	SA7S/50	HOSE ADAPTOR
26	SA7S/26	O-RING		SA7S/RG	RANDOM BALANCE GUARD

Original Date: 220800
 Issue Date: 220800
 Issue No: 1
 Date Modified: N/A

NOTE: It is our policy to continually improve products and as such we reserve the right to alter data, specifications and component parts without prior notice. **IMPORTANT:** No liability is accepted for incorrect use of this equipment. **WARRANTY:** Guarantee is 12 months from purchase date, proof of which will be required for any claim. **INFORMATION:** Call us for a copy of our latest catalogue and promotions on 01284 757525 and leave your full name and address including your postcode.

SEALEY POWER PRODUCTS

Sole UK Distributor, Sealey Group, Bury St. Edmunds, Suffolk.



01284 757500



01284 703534

E-mail: sales@sealey.co.uk

1.2. LEAD PAINT WARNING!
 Paint once contained lead as a traditional ingredient. Contact with the dust from the removal of such paint is toxic and must therefore be avoided. The following action must be taken before using the sander on a surface that you suspect may contain lead paint.

- User must determine potential hazard relating to age of paint to be removed. (Modern paints do not have lead content).
- DANGER!** Keep all persons and pets away from the working area. The following persons are particularly vulnerable to the effects of lead paint dust: *Expectant women, babies and children.*
- We recommend personal protection by using the following safety items:
 - Paint Spray Respirator (Our ref SSP16EN)
 - PE Coated Hooded Coverall (Our ref SSP266).
 - Latex Gloves (Our ref SSP24).
- Take adequate measures to contain the paint dust, flakes and scrapings.
- Continue to wear safety equipment as in (3) above and thoroughly clean all areas when task is complete. Ensure paint waste is disposed of in sealed bags or containers.

2. INTRODUCTION & SPECIFICATIONS

The SA7/S has a light weight aluminium body with a smooth double bearing counter balance assembly for fatigue-free operation.

Pad size	150mm	Air Inlet	1/4" BSP
Thread size5/16" UNF	Sound93.3dB (A)
Free Speed10000rpm92.8dB (C)
Operating Pressure90psi	Vibration	<2.5m/s ²
Air Consumption4cfm	Weight2kg

3. PREPARING SANDER FOR USE

- ### 3.1. Air Supply
- Ensure the sander air valve (or throttle) is in the "off" position before connecting to the air supply.
 - You will require an air pressure between 70-90psi, and an air flow according to the specification above.
 - WARNING!** Ensure the air supply is clean and does not exceed 90 psi while operating the sander. Too high an air pressure and unclean air will shorten the product life due to excessive wear, and may be dangerous causing damage and/or personal injury.
 - Drain the air tank daily. Water in the air line will damage the sander **and will invalidate your warranty.**
 - Clean air inlet filter weekly. Recommended hook-up procedure is shown in fig 1.
 - Line pressure should be increased to compensate for unusually long air hoses (over 8 metres). The minimum hose diameter should be 1/4" I.D. and fittings must have the same inside dimensions.
 - Keep hose away from heat, oil and sharp edges. Check hoses for wear, and make certain that all connections are secure.

3.2. Couplings.

Vibration may cause failure if a quick change coupling is connected directly to the air sander. To overcome this, connect a leader hose to the sander. A quick change coupling may then be used to connect the leader hose to the air line recoil hose. See fig 1 & 2.

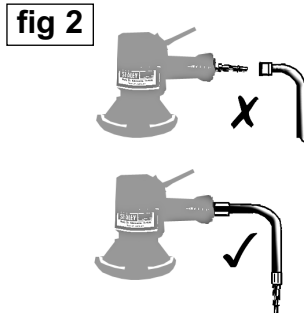
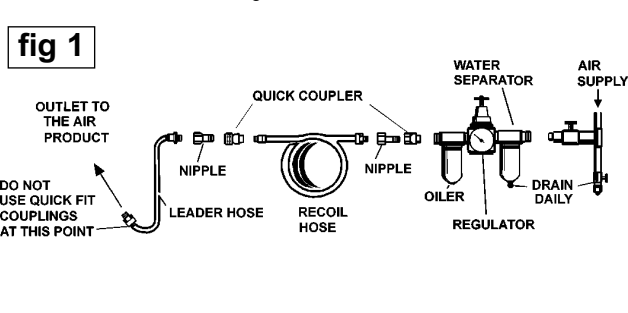

4. OPERATING INSTRUCTIONS

WARNING! Ensure you read, understand and apply safety instructions fore use.

- ### 4.1. Assembly.
- Apply appropriate sanding pad to the backing disc. Use only pads with speed ratings equal to or higher than the speed rating of the sander. **DO NOT** use cloth backed sanding pads.
 - Connect air supply to sander and press the control valve lever and check that the sander is working correctly.
 - The air flow may be regulated by turning the control knob on the side of the handle.

4.2. Operating.

The sander is designed to provide two sanding actions, "rotary" and "random orbit". These actions are controlled by the spindle lock position (fig 3). For a random orbit, turn the spindle lock so that the flat (A) faces the drive spindle (B). For rotary action turn the spindle lock so the flat is away from the drive spindle.

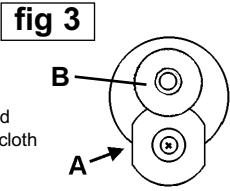

Always use grit pad appropriate for the job. Work progressively from coarse grades to finer grades. **DO NOT** go from coarse to fine in one step as it may be difficult to remove swirl marks left by the coarser grit. **DO NOT** apply excessive pressure, let the sander do the work for you. Start the sander and bring the sanding disc to the the work surface evenly and slowly. Move the sander back and forth in overlapping areas. Remove the sanding disc from the work surface before stopping the sander. Regularly check the sanding pad for wear, always changed a cracked or damaged pad.

DO NOT allow sander to run in "idle rotation" for an extended period of time as this will shorten life of bearings.

5. MAINTENANCE

- WARNING!** Disconnect sander from air supply before changing accessories, servicing or performing maintenance. Replace or repair damaged parts. *Use genuine parts only. Non-authorized parts may be dangerous and will invalidate the warranty.*
- Lubricate the air sander daily with a few drops of good grade air tool oil such as Sealey ATO/500 or ATO1000, dripped into the air inlet before use.
 - Clean the sander after use and change pads when required.
 - Loss of power or erratic action may be due to the following:
 - Excessive drain on the air line. Moisture or restriction in the air pipe. Incorrect size or type of hose connectors. To remedy check the air supply and follow instructions in chapter 3.
 - Grit or gum deposits in the sander may also reduce performance. If your model has an air strainer (located in the area of the air inlet), remove the strainer and clean it. Flush the sander out with gum solvent oil or an equal mixture of SAE No 10 oil and kerosene. Allow to dry before use.

If you continue to experience problems, contact your local Sealey service agent.
 - For a full service contact your local Sealey service agent.
 - When not in use, disconnect from air supply, clean sander and store in a safe, dry, childproof location.

Declaration of Conformity

CE We, the sole importer into the UK, declare that the product listed here is in conformity with the following EEC standards and directives. The construction file for this product is held by the Manufacturer and may be inspected, by a national authority, upon request to Jack Sealey Ltd.

Air Operated Orbital Sander
Model: SA7/S
 98/37/EC Machinery Directive
 93/68/EEC Marking Directive

Signed by Mark Sweetman

 22nd August 2000
For Jack Sealey Ltd. Sole importer into the UK of Sealey Power Products.