

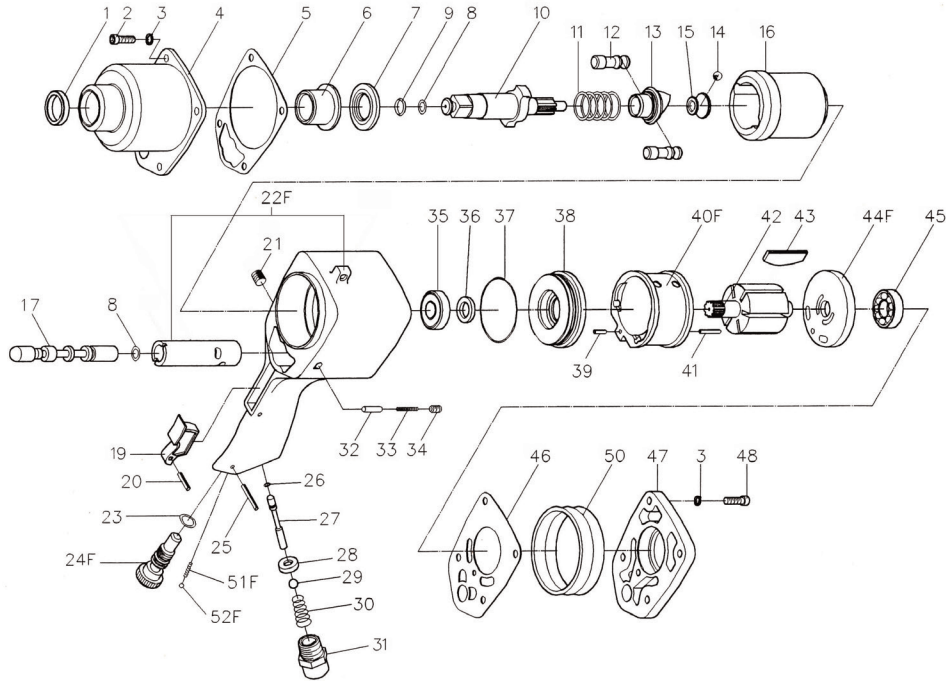

Parts Information:  
**Air Impact Wrench 1/2" Sq Drive Extra Heavy-Duty**  
**Model No: SA5/S.V3**



Item	Part No.	Description
1	SA5S.V3-01	OIL SEAL
2	SA5S.V3-02	CAP SCREW
3	SWM5.SB	SPRING WASHER M5 BLACK (SINGLE)
4	SA5S.V3-04	HAMMER CASE
5	SA5S.V3-05	FRONT GASKET
6	SA5S.V3-06	ANVIL BUSHING
7	SA5S.V3-07	SPACER
8	SA5S.V3-08	O-RING
9	SA5S.V3-09	ANVIL COLLAR
10	SA5S.V3-10	ANVIL 1"
11	SA5S.V3-11	SPRING
12	SA5S.V3-12	HAMMER PIN
13	SA5S.V3-13	DRIVE CAM
14	SB-8.0	STEEL BALL 8.0mm
15	SA5S.V3-15	CAM
16	SA5S.V3-16	HAMMER CAGE
17	SA5S.V3-17	REVERSE VALVE
19	SA5S.V3-19	TRIGGER
20	SA5S.V3-20	SPRING PIN
21	SA5S.V3-21	SET SCREW
22F	SA5S.V3-22F	HOUSING (incl. part 18)
23	SA5S.V3-23	O-RING
24F	SA5S.V3-24F	AIR REGULATOR
25	SA5S.V3-25	SPRING PIN M3X25
26	SA5S.V3-26	O-RING

Item	Part No.	Description
27	SA5S.V3-27	VALVE STEM
28	SA5S.V3-28	BUSHING
29	SB-9.5	STEEL BALL 9.5mm
30	SA5S.V3-30	SPRING
31	SA5S.V3-31	AIR INLET (1/4"PT)
32	SA5S.V3-32	PIN
33	SA5S.V3-33	SPRING
34	GSM58.S	GRUB SCREW M5x8 (SINGLE)
35	B/6001Z	BEARING 6001Z
36	SA5S.V3-36	OIL SEAL
37	SA5S.V3-37	O-RING
38	SA5S.V3-38	FRONT END PLATE
39	SA5S.V3-39	SPRING PIN
40F	SA5S.V3-40F	CYLINDER
41	SA5S.V3-41	SPRING PIN M3X18
42	SA5S.V3-42	ROTOR
43	SA5S.V3-43	ROTOR BLADE
44F	SA5S.V3-44F	REAR END PLATE
45	B/6001	BEARING 6001
46	SA5S.V3-46	REAR GASKET
47	SA5S.V3-47	REAR COVER
48	SA5S.V3-48	CAP SCREW
50	SA5S.V3-50	RUBBER PROTECTOR
51F	SA5S.V3-51E	SPRING
52F	SB-4.0	STEEL BALL 4.0mm

**NOTE:** It is our policy to continually improve products and as such we reserve the right to alter data, specifications and component parts without prior notice.

**IMPORTANT:** No liability is accepted for incorrect use of product.

**WARRANTY:** Guarantee is 12 months from purchase date, proof of which will be required for any claim.

Sealey Group, Kempson Way, Suffolk Business Park, Bury St Edmunds, Suffolk. IP32 7AR



01284 757500



01284 703534



sales@sealey.co.uk



www.sealey.co.uk