

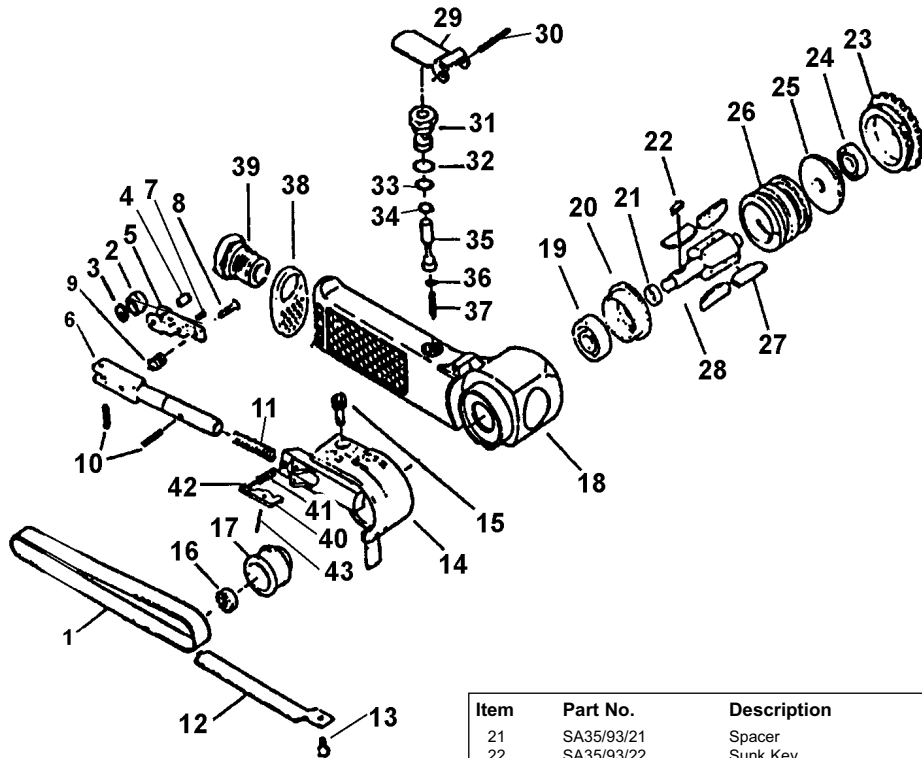

INSTRUCTIONS FOR AIR OPERATED 10mm BELT SANDER Model: SA35

Thank you for purchasing a Sealey Product. Manufactured to a high standard this product will, if used according to these instructions and properly maintained, give you years of trouble free performance.

IMPORTANT: PLEASE READ THESE INSTRUCTIONS CAREFULLY. NOTE THE SAFE OPERATIONAL REQUIREMENTS, WARNINGS AND CAUTIONS. USE THIS PRODUCT CORRECTLY AND WITH CARE FOR THE PURPOSE FOR WHICH IT IS INTENDED. FAILURE TO DO SO MAY CAUSE DAMAGE AND/OR PERSONAL INJURY AND WILL INVALIDATE THE WARRANTY. PLEASE KEEP INSTRUCTIONS SAFE FOR FUTURE USE.



Item	Part No.	Description
1	SA35/B60G SA35/B80G SA35/B100G SA35/B120G	Belt, 60G (pack of 5) Belt, 80G (pack of 5) Belt, 100G (pack of 5) Belt, 120G (pack of 5)
2	‡	Idle Pulley Sub Ass'y
3	‡	Washer
4	‡	Idle Pulley Shaft
5	‡	Bracket
6	‡	Tension Bar
7	‡	Hex Set Screw
8	‡	Screw
9	‡	Spring
10	‡	Spring Pins
11	‡	Spring
12	SA35/93/12	Shoe
13	SA35/93/13	Screw
14	‡SA35/93/14	Guard Sub Assembly
15	‡SA35/93/15	Hex Bolt
16	SA35/93/16	Hex Nut
17	SA35/93/17	Drive Pulley
18	SA35/93/18	Housing
19	B/628ZZ	Bearing
20	SA35/93/20	End Plate

Item	Part No.	Description
21	SA35/93/21	Spacer
22	SA35/93/22	Sunk Key
23	SA35/93/23	Cap
24	B/607ZZ	Ball Bearing
25	SA35/93/25	End Plate
26	SA35/93/26	Cylinder
27	SA35/93/27	Blade Ass'y
28	SA35/93/28	Rotor
29	SA35/93/29	Throttle Lever
30	SA35/93/30	Lever Pin
31	SA35/93/31	Valve Body
32	SA35/93/32	O-Ring
33	SA35/93/33	O-Ring
34	SA35/93/34	O-Ring
35	SA35/93/35	Valve Stem
36	SA35/93/36	O-Ring
37	SA35/93/37	Valve Spring
38	SA35/93/38	Deflector
39	SA35/93/39	Air Inlet
40	‡	Tension Bar
41	‡	Spring
42	‡	Lever Pin
43	‡	Lever Pin
‡	SA35/93/06-TBA	Tension Bar Ass'y

Items marked '‡' are components of Tension Bar Assembly.
Items 14 & 15 are also available separately.

1. SAFETY INSTRUCTIONS

- ⓘ **WARNING!** Ensure Health & Safety, local authority, and general workshop practice regulations are adhered to when using this equipment.
- ⓘ **WARNING!** Disconnect from air supply before changing accessories or servicing.
- 3 Maintain the sander in good condition (use an authorised service agent).
- 3 Replace or repair damaged parts. Use genuine parts only. Unauthorised parts may be dangerous and will invalidate the warranty.
- 3 Use in suitable clean and tidy working area, free from unrelated materials and ensure there is adequate lighting.
- 3 Before each use check abrasive belt for condition. If worn or damaged replace immediately.
- 3 Use only the correct size and type of sanding belt with this sander.
- 3 Ensure there are no flammable or combustible materials near the work area.
- ⓘ **WARNING!** Always wear approved eye or face and hand protection when operating the sander.
- 3 Use face, dust, or respiratory protection in accordance with COSHH regulations.
- 3 Depending on the task, sander noise level may exceed 85dB, in which case wear safety ear defenders.
- 3 Remove ill fitting clothing. Remove ties, watches, rings, other loose jewellery and contain and/or tie back long hair.
- 3 Wear appropriate protective clothing and keep hands and body clear of working parts.
- 3 Maintain correct balance and footing. Ensure the floor is not slippery and wear non-slip shoes.
- 3 Keep children and unauthorised persons away from the work area.
- 3 Check moving parts alignment on a regular basis.
- 3 Ensure workpiece is secure before operating the sander. Never hold a workpiece by hand.
- 3 Check the workpiece to ensure there are no protruding screws, bolts, nuts, nails, rivets, etc.
- 3 Avoid unintentional starting.
- ⓘ **WARNING!** Ensure correct air pressure is maintained and not exceeded. Recommended pressure 70-90psi.
- 3 Keep air hose away from heat, oil and sharp edges. Check air hose for wear before each use and ensure that all connections are secure.
- 3 Prolonged exposure to vibration from this sander poses a health risk. It is the owner's responsibility to correctly assess the potential hazard and issue guidelines for safe periods of use and offer suitable protective equipment.
- 7 DO NOT use the sander for a task it is not designed to perform.
- 7 DO NOT operate sander if any parts are damaged or missing as this may cause failure and/or personal injury.
- ⓘ **WARNING!** DO NOT sand any materials containing asbestos.
- 7 DO NOT carry the sander by the hose, or yank the hose from the air supply.
- 7 DO NOT force, or apply heavy pressure to, the sander, let the sander do the work.
- 7 DO NOT switch the sander on whilst the belt is in contact with the workpiece.
- 7 DO NOT operate sander when you are tired or under the influence of alcohol, drugs or intoxicating medication.
- 7 DO NOT use sander where there are flammable liquids, solids or gases such as paint solvents and including waste wiping or cleaning rags etc.
- 7 DO NOT carry the sander with your finger on the power lever.
- 7 DO NOT direct air from the air hose at yourself or others.
- 3 When not in use disconnect from air supply and store in a safe, dry, childproof location.

NOTE: It is our policy to continually improve products and as such we reserve the right to alter data, specifications and component parts without prior notice. **IMPORTANT:** No liability is accepted for incorrect use of this equipment. **WARRANTY:** Guarantee is 12 months from purchase date, proof of which will be required for any claim. **INFORMATION:** For a copy of our latest catalogue and promotions call us on 01284 757525 and leave your full name and address, including postcode.

SEALEY POWER PRODUCTS Sole UK Distributor, Sealey Group, Bury St. Edmunds, Suffolk.
 ☎ 01284 757500 📠 01284 703534 ✉ sales@sealey.co.uk



1.2. LEAD PAINT WARNING!

Paint once contained lead as a traditional ingredient. The dust from the removal of such paint is toxic if ingested/inhaled and must, therefore, be avoided. The following actions must be taken before using the sander on a surface that you suspect may contain lead paint.

1. User must determine potential hazard relating to age of paint to be removed. (Modern paints do not have lead content).
2. **DANGER!** Keep all persons and pets away from the work area. The following persons are particularly vulnerable to the effects of lead paint dust: *Expectant women, babies and children.*
3. We recommend personal protection by using the following safety items:
 - a) Paint Spray Respirator (Sealey ref. SSP16EN)
 - b) PE Coated Hooded Coverall (Sealey ref. SSP266). c) Latex Gloves (Sealey ref. SSP24).
4. Take adequate measures to contain the paint dust, flakes and scrapings.
5. Continue to wear safety equipment as in (3) above and thoroughly clean all areas when task is complete. Ensure paint waste is disposed of in sealed bags or containers.

2. INTRODUCTION & SPECIFICATION

The SA35 Belt Sander features an articulated sanding arm, belt tracking control, heavy-duty nose roller and one-handed trigger operation. Suitable for sanding areas with limited access.

Specification

Belt	10 x 320mm	Weight0.8kg
Air Pressure	90psi	Airborne Noise87.8dB (A)
Air Consumption12cfm		86.5dB (C)
Air inlet	1/4" BSP	Vibration level	<2.5m/s ²

3. PREPARING FOR USE

3.1. Air Supply

- 3.1.1. Ensure the sander air valve (or throttle) is in the "off" position before connecting to the air supply.
- 3.1.2. You will require an air pressure between 70-90psi, and an air flow of 12cfm.
- 3.1.3. **WARNING!** Ensure the air supply is clean and does not exceed 90 psi. Too high an air pressure and unclean air will shorten the product life due to excessive wear, and may be dangerous causing damage and/or personal injury.
- 3.1.4. Drain the air tank daily. Water in the air line will damage the sander **and will invalidate your warranty.**
- 3.1.5. Clean compressor air inlet filter weekly. Recommended hook-up procedure is shown in fig.1.
- 3.1.6. Line pressure should be increased to compensate for unusually long air hoses (over 8 metres). The minimum hose size should be 1/4" I.D. and fittings must have the same inside dimensions.
- 3.1.7. Keep hoses away from heat, oil and sharp edges. Check hoses for wear, and make certain that all connections are secure.

3.2. Couplings.

Vibration may cause failure if a quick change coupling is connected directly to the air sander. To overcome this, connect a leader hose to the sander. A quick change coupling may then be used to connect the leader hose to the air line recoil hose. See figs.1 & 2.

fig. 1

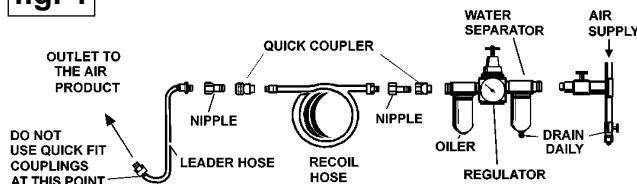
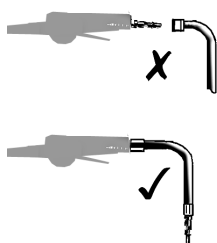

fig. 2



4. OPERATING INSTRUCTIONS

- 4.1. Unpack the product and check contents against the parts listed below. If there is anything damaged or missing contact your supplier immediately.

Contents: a) SA35 Belt Sander.
b) 3 x Sanding Belt c) 2 x Hex. Key

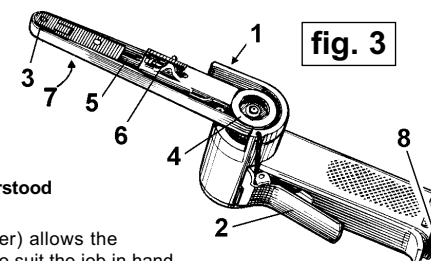

WARNING! Ensure that you have read and understood the safety instructions in Section 1.

- 4.2. Loosening clamp bolt (fig.3.1. on the top of sander) allows the angle between the grip and the belt to be altered to suit the job in hand. After adjustment retighten the clamp bolt.
- 4.3. Once connected to the air supply the sander is started by squeezing the trigger (2).
- 4.4. To remove and replace the sanding belt push the idle pulley (3) towards the drive pulley (4) against spring pressure. The pulley bracket (5) will retract and lock allowing removal/fitting of the belt. When the new belt is in position release the pulley bracket by pushing in and holding the idle pulley, then press and hold the tension bar (6) whilst releasing the pressure on the idle pulley.
- 4.5. The tracking of the belt can be altered by adjusted cross head screw (7).

5. MAINTENANCE

WARNING! Disconnect sander from air supply before changing accessories, servicing or performing maintenance. Replace or repair damaged parts. *Use genuine parts only. Unauthorised parts may be dangerous and will invalidate the warranty.*

- 5.1. If the air supply system does not have an oiler lubricate the sander daily with a few drops of a good grade air tool oil, such as Sealey ATO/500 or ATO/1000, dripped into the air inlet (fig.3.8) before use.
- 5.2. Clean the sander after use and change belt when required.
- 5.3. Loss of power or erratic action may be due to the following:
 - a) Excessive drain on the air supply. Moisture or restriction in the air line. Incorrect size or type of hose connectors. To remedy, check the air supply and follow instructions in Section 3.
 - b) Grit or gum deposits in the sander may also reduce performance. If your model has an air filter (located in the area of the air inlet), remove the filter and clean it. Flush the sander out with gum solvent oil or an equal mixture of SAE No. 10 oil and kerosene. Allow to dry before use.
 If you continue to experience problems, contact your local Sealey service agent.
- 5.4. For a full service contact your local Sealey service agent.
- 5.5. When not in use, disconnect from air supply, clean and store in a safe, dry, childproof location.

Declaration of Conformity



We, the sole importer into the UK, declare that the product listed here is in conformity with the following standards and directives. The construction file for this product is held by the Manufacturer and may be inspected, by a national authority, upon request to Jack Sealey Ltd.

Air Operated 10mm Belt Sander Model SA35

98/37/EC Machinery Directive
93/68/EEC Marking Directive

Signed by Mark Sweetman

30th March 2001

For Jack Sealey Ltd. Sole distributor in the UK
of Sealey Power Products.