

Item	Part No.	Description
1	S0816.01	TOP COVER
2	SMIG150.V3-37	SPOOL HOLDER
3	SMIG150.V3-19	CONTROL TRANSFORMER
4	SMIG150.V3-26	PIN
5	SMIG150.V3-38	WIRE FEEDER
6	S0816.06	MIDDLE PANEL
7	SMIG230.32	WHEEL, FIXED (151x12x36)
8	SMIG275.01	CHAIN
9	S0816.09	GAS BOTTLE HOLDER
10	SMIG150.V3-31	GAS HOSE CONNECTOR
11	S0816.11	BACK PANEL
12	180XT.19	FAN
13	SMIG150.V3-25	WHEEL AXLE BRACKET
14	SMIG150.V3-28	WHEEL AXLE
15	S0816.15	RECTIFIER HOLDER
16	S0816.16	BOTTOM
17	SMIG150.V3-20	MAIN TRANSFORMER
18	S0816.18	RIGHT SIDE PANEL

Item	Part No.	Description
19	SMIG180.V3-44	THERMAL RELAY
20	SMIG150.V3-15	FEET
21	S0817.21	SWITCH
22	S0816.22	FRONT PANEL
23	250XTD.28	CABLE HOLDER
24	S0816.24	INDICATOR
25	MC3CX1.5	MAINS CABLE BLK, 3 CORE, 1.5MM2
26	SMIG150.V3-12	GROUNDING CABLE
27	PMIG6035S.W25	POTENTIOMETER KNOB
28	SMIG130.27	MIG TORCH
29	S0816.29	HANDLE
30	SMIG150.V3-07	TORCH HOLDER
31	S0816.31	LEFT SIDE PANEL
32	SMIG150.V3-17	PCB SUPPORT
33	SMIG130.19	PCB
34	S0816.34	RECTIFIER
--	S0816.35	GAS REGULATOR (NOT SHOWN)

**NOTE:** It is our policy to continually improve products and as such we reserve the right to alter data, specifications and component parts without prior notice.

**IMPORTANT:** No liability is accepted for incorrect use of product.

**WARRANTY:** Guarantee is 12 months from purchase date, proof of which will be required for any claim.

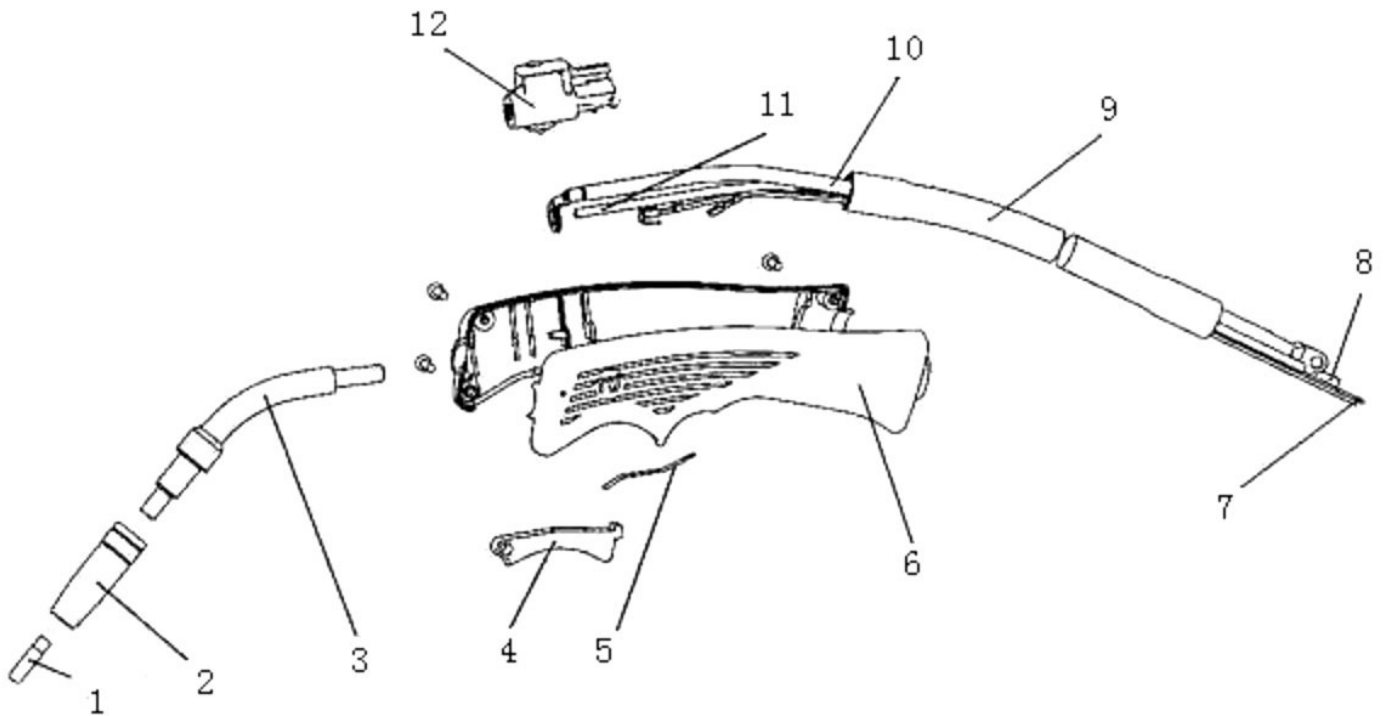

Item	Part No.	Description
1	MIG956	CONTACT TIP 0.6mm TB15 Pack of 5
	MIG957	CONTACT TIP 0.8mm TB15 Pack of 5
2	MIG955	CONICAL NOZZLE TB15 Pack of 3
3	SMIG150.V3-8C	SWAN NECK
--	120/722319	SPRING for NOZZLE TB15 (NOT SHOWN)
4	SMIG130.27-4	SWITCH
5	SMIG130.27-5	SWITCH CONTACT PLATE
6	SMIG130.27-6	TORCH HANDLE

Item	Part No.	Description
7	SMIG130.27-7	CONTROL CABLE
8	SMIG130.27-8	GAS HOSE 7mm x 9mm x 2800mm
9	SMIG130.27-9	PROTECTION TUBE
10	SMIG130.27-10	MAIN CABLE
11	SMIG130.27-11	LINER
12	SMIG150.V3-8L	GAS VALVE
--	SMIG130.27-13	HANDLE SCREW (NOT SHOWN)

**NOTE:** It is our policy to continually improve products and as such we reserve the right to alter data, specifications and component parts without prior notice.

**IMPORTANT:** No liability is accepted for incorrect use of product.

**WARRANTY:** Guarantee is 12 months from purchase date, proof of which will be required for any claim.