

INSTRUCTIONS FOR:
SNAP BODY REPAIR KIT
 Model: **RE97/10C**

Thank you for purchasing a Sealey product. Manufactured to a high standard this product will, if used according to these instructions and properly maintained, give you years of trouble free performance.

IMPORTANT: PLEASE READ THESE INSTRUCTIONS CAREFULLY. NOTE THE SAFE OPERATIONAL REQUIREMENTS, WARNINGS & CAUTIONS. USE THE PRODUCT CORRECTLY AND WITH CARE FOR THE PURPOSE FOR WHICH IT IS INTENDED. FAILURE TO DO SO MAY CAUSE DAMAGE AND/OR PERSONAL INJURY AND WILL INVALIDATE THE WARRANTY. PLEASE KEEP INSTRUCTIONS SAFE FOR FUTURE USE.

Only fully trained and qualified persons should use this equipment. These instructions are not a substitute for user receiving full supervised training by a qualified person. It is important the user understands the applications, limitations and potential hazards of the product.

1. SAFETY INSTRUCTIONS

- p **WARNING!** Ensure Health & Safety, local authority and general workshop practice regulations are adhered to when using this equipment.
- 3 Familiarise yourself with the application and limitations, as well as the specific potential hazards, of the repair kit.
- p **WARNING!** No part of this unit or any accessory relating to the repair kit is designed for lifting loads. It is intended only as a pushing device and must be used as such, with care.
- p **WARNING!** Disconnect the repair kit from the hydraulic pump before servicing or performing any maintenance on the unit.
- 3 Maintain repair kit in good order. Replace/repair with *genuine parts only*. *Unauthorised parts may be dangerous and will invalidate the warranty.*
- 3 Use qualified person to lubricate and maintain the hydraulic pump. **DO NOT** use brake fluid to top up hydraulic unit. Use Sealey hydraulic oil only.
- 3 Keep the repair kit clean for best and safest performance.
- p **WARNING!** Ensure you know how much load you are pushing. **Never exceed the maximum pushing capacity.**
- 3 Use only with the supplied Sealey hydraulic pump and accessories. Other equipment may damage unit and will invalidate your warranty.
- 3 The kit accessories may be used with other popular makes of kit.
- 3 Ensure there is positive engagement of repair kit accessories with the vehicle body before pushing.
- 3 Maintain correct balance and footing. Ensure the floor is not slippery and wear non-slip shoes.
- 3 If working on an 'off centre' load, pump with care. If you feel undue resistance, stop and re-adjust the set-up.
- p **WARNING!** Keep your hands, body and clothing away from the repair kit and accessories when in use. Take any necessary precautions to protect your personal safety and that of others whilst using the repair kit.
- 3 Ensure the hydraulic hose is not bent or kinked.
- 3 Keep non-essential persons away from the operating area. Be aware of the locations of other persons assisting you.
- 3 When releasing tension from the load be sure to undo the hydraulic valve VERY slowly.
- 7 **DO NOT** operate the repair kit if any parts are damaged or missing as this may cause failure and/or personal injury.
- p **WARNING!** **DO NOT use repair kit as a lifting device of any type. DO NOT use for any purpose other than for which it is designed.**
- 7 **DO NOT** over extend the ram as the plunger may be forced out of the cylinder.
- 7 **DO NOT** heat accessories as this may weaken them.
- 7 **DO NOT** modify accessories for use with this kit.
- 3 When not in use, place dust cap on end of hydraulic hose and store the kit, in the case, in a safe, dry, childproof location.

2. CONTENT

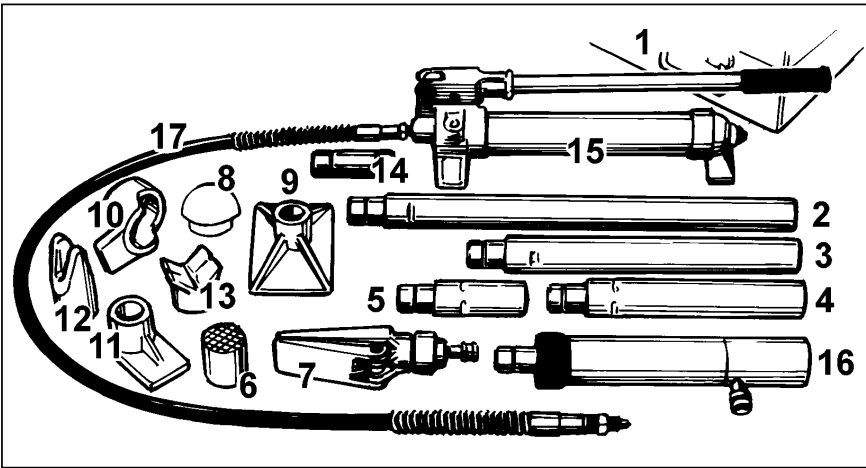

ITEM	PART NO.	DESCRIPTION
1	810/01	Box, Metal
2	604/A02	Tube, Extension, 27"
3	604/A03	Tube, Extension, 18"
4	604/A04	Tube, Extension, 10"
5	604/A05	Tube, Extension, 5"
6	810/07	Saddle, Serrated, Push-in
7	610/11	Wedge Ram
8	810/12	Head, Rubber, Ø3½", Push-in
9	810/13	Base, Flat, Push-in
10	810/14	Toe, Spreader Ram, Push-in
11	810/15	Toe, Spreader Plunger, Push-in
12	810/16	Head, Wedge, Push-in
13	810/17	Base, V-shape, 90°, Push-in
14	810/18	Connector, Push-in
15	610/40	Pump
16	810/41	Ram, 10 Ton
17	610/42	Hose, c/w Half Coupling

3. INTRODUCTION

Kit features heavy gauge snap-together pipe-work and cast snap-together attachments compatible with most leading makes of snap-together equipment. Hydraulic ram is capable of a thrust of 10 tons.

IMPORTANT:

Only fully trained and qualified persons should use this equipment. It is important that the user understands the applications, limitations and potential hazards of the equipment.

VEHICLE DAMAGE INTRODUCTION

Before using the repair kit, you must determine the extent of vehicle damage. Check all parts and determine whether there are any broken, torn, crumpled, wrinkled, crushed, twisted or bent metallic parts. Measurements should be taken to see how far the vehicle is out of alignment. It is important to determine correct dimensions by referring to the manufacturer's frame dimension charts and specifications. Remember, do not commence pushing until you are sure when to stop. Take time to examine and determine damage correctly. Comprehensive planning will save you time when using the equipment.

4. INSTRUCTIONS FOR USE

To provide maximum versatility a combination of ram accessories may be used.

Illustrated below are the main attachment variations.

Ensure the task you are undertaking falls within the capacity of the pump and accessories you are using.

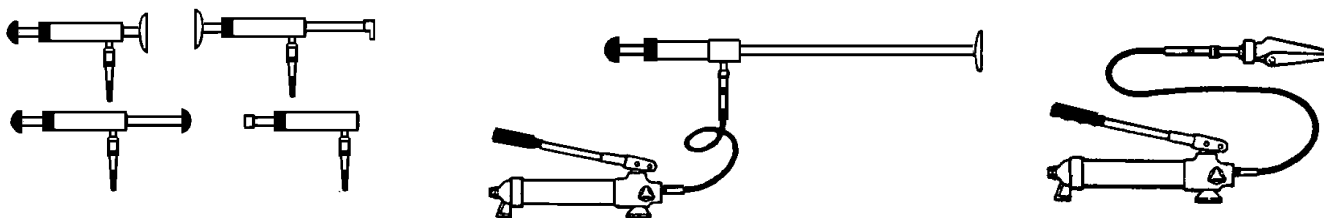

WARNING! Ensure you have read and understand *Section 1 Safety Instructions*.

- 4.1. The pump may be used in any position from horizontal to vertical. When not horizontal ensure the hose end of the pump is down.
- 4.2. To use the pump, close valve (fig. 1.A) by turning the knob clockwise and pump the handle up and down to apply the load.
- 4.3. To release pump pressure, turn knob anti-clockwise (B).

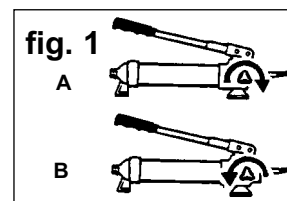

5. MAINTENANCE

IMPORTANT: Only fully qualified personnel should attempt maintenance or repair of the hydraulic system.

5.1. Pump oil level

Release pressure and disconnect the ram from the pump.

Hold pump in an upright position.

Remove filler plug and add hydraulic oil until it is level with the full mark (fig. 2).

WARNING: DO NOT use brake fluid, or any fluid other than hydraulic jack fluid, as this may cause serious damage to the pump/ram and will invalidate the warranty! Use only Sealey hydraulic oil.

5.2. General

Before each use check for broken, cracked, bent, or loose parts, or any visible damage to welds, ram, pump, hose and accessories. If any suspect item is found, remove from service and take necessary action to remedy the problem.

Replace/repair with *genuine parts only*. *Unauthorised parts may be dangerous and will invalidate the warranty*.

Keep all parts of the kit clean.

5.3. De-commissioning hydraulic pump/ram

Should the pump or ram become completely unserviceable draw off the oil into an approved container and dispose of the product and the oil according to local regulations.

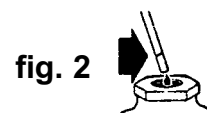

IMPORTANT: NO RESPONSIBILITY IS ACCEPTED FOR INCORRECT USE OF THE PUMP AND/OR RAM.

Hydraulic products are only repaired by local service agents. We have service/repair agents in all parts of the UK.

DO NOT RETURN PUMP OR RAM TO US. Please call us on 01284 757500 to obtain the address and telephone number of your local agent. If product is under guarantee please contact your dealer.

Declaration of Conformity

We, the sole importer into the UK, declare that the product listed below is in conformity with the following standards and directives.

SNAP BODY REPAIR KIT
Model: RE97/10C
98/37/EC Machinery Directive



The construction file for this product is held by the Manufacturer and may be inspected, by a national authority, upon request to Jack Sealey Ltd.

Signed by Mark Sweetman

A handwritten signature of Mark Sweetman is shown.

4th November 2000

For Jack Sealey Ltd. Sole importer into the UK of Sealey Power Products.

NOTE: It is our policy to continually improve products and as such we reserve the right to alter data, specifications and component parts without prior notice.

IMPORTANT: No liability is accepted for incorrect use of this product.

WARRANTY: Guarantee is 12 months from purchase date, proof of which will be required for any claim.

INFORMATION: For a copy of our latest catalogue and promotions call us on 01284 757525 and leave your full name and address, including postcode.



Sole UK Distributor,
Sealey Group,
Bury St. Edmunds, Suffolk.



01284 757500



01284 703534

E-mail: sales@sealey.co.uk