

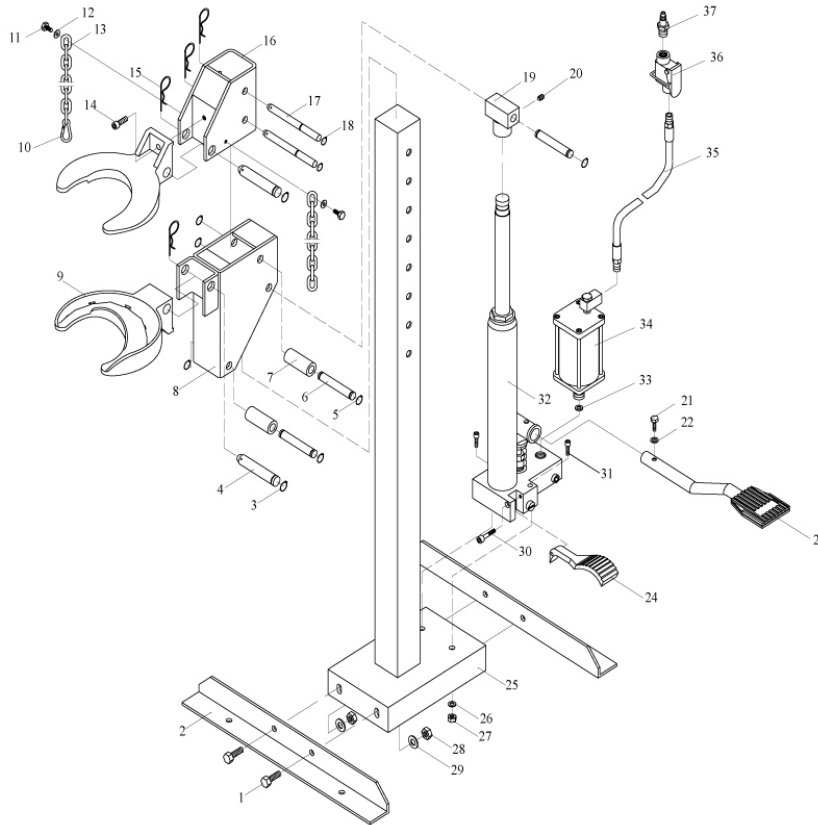

Parts Information:
**Coil Spring Compressing Station Air/
 Hydraulic**
Model No: RE232



Item	Part No.	Description
1	SS1025.S	Hex Head Set Screw m10x25mm Single
2	RE231.02	Bracket
3	RE231.03	Ext Circlip 20.2mm OD.
4	RE231.04	Locating Pin 18x100mm
5	RE231.05	Ext Circlip 15.7mm OD.
6	RE231.06	Locating Pin 14x87mm
7	RE231.07	Bushing
8	RE231.08	Lower Strut Support
9	RE231.09	Curved Coil Bracket (Supplied As Singles)
--	RE231.09A	Curved Coil Bracket (Small) (Supplied As Singles) (NOT SHOWN)
10	RE231.10	Shackle
11	SS616.S	Hex Head Set Screw m6x16mm Single
12	FWM6.S	Flat Washer M6 Single
13	RE231.13	Chain
14	SCB820.SB	Socket Head Cap Screw m8x20 Black
15	RE231.15	Pin (R-Shaped)
16	RE231.16	Upper Strut Support
17	RE231.17	Locating Pin 12x133mm
18	RE231.18	Retaining Ring
19	RE232.19	Saddle
20	RE232.20	Screw

Item	Part No.	Description
21	RE232.21	Screw
22	FWM8.S	Flat Washer M8 Single
23	RE232.23	Lift Foot Pedal
24	RE232.24	Release Foot Pedal
25	RE231.25	Upright (Main Frame)
26	FWM8.S	Flat Washer M8 Single
27	SN8.S	Steel Nut M8 Zinc Din934 (Single)
28	SN10.S	Steel Nut M10 Zinc Din934(Single)
29	FWM10.S	Flat Washer M10 Single
30	RE232.30	Pin
31	RE232.31	SKT. HD Bolt m10x35
32	RE232.32	Ram (Old Version)
--	RE232.32N	Ram (New Version) (NOT SHOWN)
33	RE232.33	Repair Washer M6
34	RE232.34	Air Motor
35	RE232.35	Air Hose
36	RE232.36	Air Valve
37	RE232.37	Quick Coupler (Male)
--	RE232.32/ASSY	Ram Assembly (C/W Air Motor & Washer) (NOT SHOWN)
--	RE232.38	Foot Pedal Plunger/Piston (NOT SHOWN)

NOTE: It is our policy to continually improve products and as such we reserve the right to alter data, specifications and component parts without prior notice.

IMPORTANT: No liability is accepted for incorrect use of product.

WARRANTY: Guarantee is 12 months from purchase date, proof of which will be required for any claim.

Sealey Group, Kempson Way, Suffolk Business Park, Bury St Edmunds, Suffolk. IP32 7AR



01284 757500



01284 703534



sales@sealey.co.uk



www.sealey.co.uk