

NOTE: It is our policy to continually improve products and as such we reserve the right to alter data, specifications and component parts without prior notice.

IMPORTANT: No liability is accepted for incorrect use of product.

WARRANTY: Guarantee is 12 months from purchase date, proof of which will be required for any claim.



Parts Information:
Pallet Truck 2000kg 1220 x 685mm
Model No: PT1220

Item	Part No.	Description
101	PT1150/101	Pump Piston Rod
102	PT1150/102	Pin For Pump
103	PT1150/103	Cap Of Pin For Pump
104	PT1150/104	Cap Of Spring For Pump
105	PT1150/105	Spring For Pump
106	PT1150/106	Dust Ring For Pump
107	PT1150/107	Seal For Pump
108	PT1150/108	Cylinder For Pump
109	PT1150/109	O-Ring For Pump
110	PT1150/110	Screw For Pump
111	PT1150/111	Seal Washer For Pump
112	PT1150/112	Seat Of Spring For Pump
113	PT1150/113	Spring For Pump
114	PT1150/114	Spring For Pump
115	PT1150/115	Spindle Of Pumping Valve
116	PT1150/116	Seat Of Pumping Valve
117	PT1150/117	Ball For Pump 1/4"
118	PT1150/118	Base For Pump
119	PT1150/119	Bolt For Pump
120	PT1150/120	Ball For Pump
121	PT1150/121	Big Wheel For Pump
132	B/6204-2RS	Bearing 6204-2RS
133	SN10.S	Steel Nut M10 Zinc Din934(Single)
134	PT1150/134	Adjusting Screw For Pump
135	PT1150/135	Foot Pedal
136	PT1150/136	Elastic Pin For Pump
137	PT1150/137	O-Ring For Pump
138	PT1150/138	Strike Pin
139	PT1150/139	Spring For Pump
140	PT1150/140	Bolt M13x6 STD HD. For Pump
141	PT1150/141	O-Ring For Pump
142	HPT750.229	Adjusting Bolt M14x6
143	PT1150/143	Spring For Pump

Item	Part No.	Description
144	PT1150/144	Spindle Of Safety Valve For Pump
145	PT1150/145	Sealing Ring For Pump
146	PT1150/146	O-Ring For Pump
147	PT1150/147	Inner Cylinder For Pump
148	PT1150/148	Tube Dust Filter For Pump
149	PT1150/149	Retaining Ring For Pump
150	PT1150/150	Washer For Pump
151	PT1150/151	O-Ring For Pump
152	PT1150/152	Cup Packing For Pump
153	PT1150/153	Piston Rod For Pump
154	SB-18.2	Steel Ball 18.2mm
155	PT1150/155	Axle For Pump
156	PT1150/156	Housing For Pump
157	PT1150/157	Screw For Pump
158	PT1150/158	Seal Washer For Pump
159	PT1150/159	Seal Washer For Pump
160	PT1150/160	Cylinder Cap For Pump
161	PT1150/161	O-Ring For Pump
162	PT1150/162	Dust Ring For Pump
163	PT1150/163	Elastic Pin For Pump
164	PT1150/164	Bushing For Pump
165	PT1150/165	Pressure Roller For Pump
166	PT1150/166	Pin For Pump
167	PT1150/167	Elastic Pin For Pump
168	PT1150/168	Bushing For Pump
169	PT1150/169	Bracket For Pump
G	PT1150/G	Wheel,Fixed (180x20x50)
H	PT1150/H	Bracket Assembly
	PT1150/P	Pump Assembly
Q	PT1150/Q	Lowering Valve Assembly
S	PT1150/S	Safety Valve Assembly
T	PT1150/T	Hydraulic Valve Assembly
	PT1150/V	Seal Kit For Pump Unit

NOTE: It is our policy to continually improve products and as such we reserve the right to alter data, specifications and component parts without prior notice.

IMPORTANT: No liability is accepted for incorrect use of product.

WARRANTY: Guarantee is 12 months from purchase date, proof of which will be required for any claim.

Sealey Group, Kempson Way, Suffolk Business Park, Bury St Edmunds, Suffolk. IP32 7AR



01284 757500



01284 703534



sales@sealey.co.uk



www.sealey.co.uk

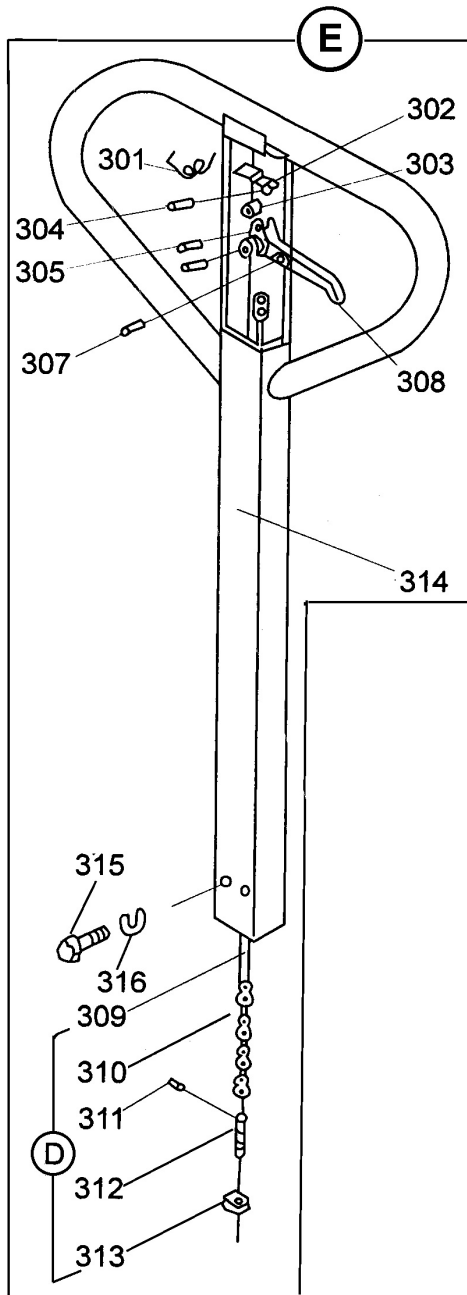

Item	Part No.	Description
301	PT1150/301	Spring For Handle
302	PT1150/302	Blade Spring
303	PT1150/303	Roller For Handle
304	PT1150/304	Elastic Pin For Handle
305	PT1150/305	Elastic Pin For Handle
307	PT1150/307	Spring Pin M4.4 x 12 Zinc
308	PT1150/308	Control Lever For Handle
309	PT1150/309	Pull Rod Only, For Handle

Item	Part No.	Description
310 - 312	PT1150/310	Chain Assembly (Includes 311&312)
313	NLN5.S	Nyloc Nut M5 Zinc Din 985 (Single)
314	PT1150/314	Handle Only
315	PT1150/315	Bolt For Handle M8x50
316	PT1150/316	Spring Washer M8
--	SWM8.S	Spring Washer M8 Zinc (Single) (NOT SHOWN)
D	PT1150/D	Chain Assembly(Pull Rod,Chain&Bracket)
E	PT1150/E	Handle Assembly

NOTE: It is our policy to continually improve products and as such we reserve the right to alter data, specifications and component parts without prior notice.

IMPORTANT: No liability is accepted for incorrect use of product.

WARRANTY: Guarantee is 12 months from purchase date, proof of which will be required for any claim.

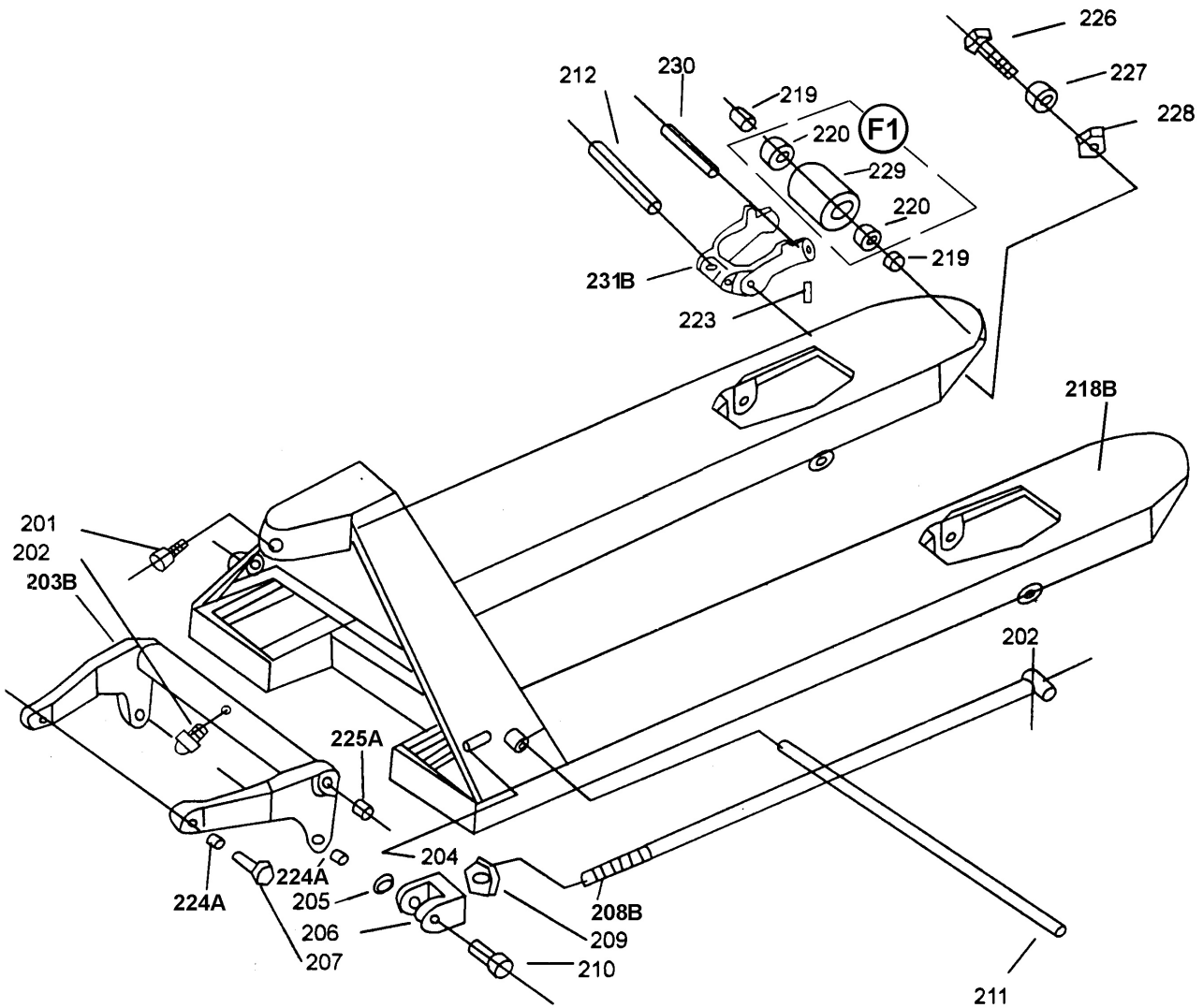

Item	Part No.	Description
201	SCB812.S	Socket Cap Bolt Zinc M8x12.
202	GNM19S	Grease Nipple STR 6 x 1.00mm Single
203B	PT1220/203B	Rock-Arm
204	PT1150/204	Elastic Pin
205	PT1150/205	Retaining Ring
206	PT1150/206	Joint
207	PT1150/207	Shaft
208B	PT1220/208B	Pushing Rod
209	PT1150/209	Nut
210	PT1150/210	Pin
211	PT1150/211	Shaft
212	PT1150/212	Shaft
--	PT1150/213	Elastic Pin (NOT SHOWN)
--	PT1150/214	Shaft (NOT SHOWN)
--	PT1220/215B	Frame For Roller (NOT SHOWN)

Item	Part No.	Description
--	PT1150/216	Spring Pin M5 x 32 Zinc (NOT SHOWN)
218B	PT1220/218B	Fork Frame
219	PT1150/219	Seal Washer
220	B/6204-2RS	Bearing 6204-2RS
223	PT1150/223	Spring Pin M5.5 x 35 Zinc
224A	PT1150/224A	Bushing
225A	PT1150/225A	Bushing
226	PT1150/226	Bolt
227	PT1150/227	Enter Roller
228	SN10.S	Steel Nut M10 Zinc Din934(Single)
229	PT1150/229	Load Roller
230	PT1150/230	Shaft For Roller
231B	PT1220/231B	Frame Of Roller
F1	PT1150/F1	Load Roller Ass'y (Single Type)

NOTE: It is our policy to continually improve products and as such we reserve the right to alter data, specifications and component parts without prior notice.

IMPORTANT: No liability is accepted for incorrect use of product.

WARRANTY: Guarantee is 12 months from purchase date, proof of which will be required for any claim.