

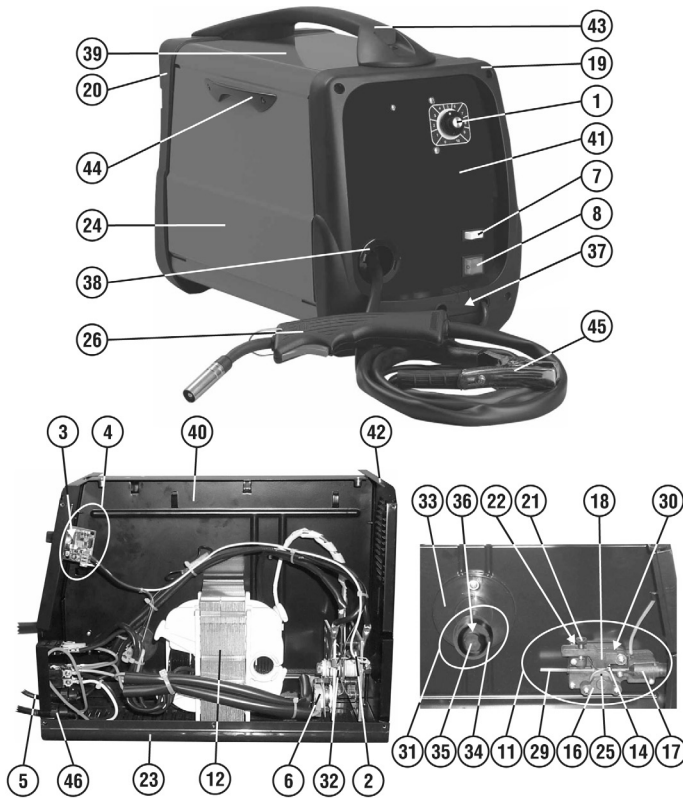

Parts Information:  
**No-Gas MIG Welder 90Amp 230V**  
**Model No: PMG100.V2**



Item	Part No.	Description
1	120.121424	Knob, Potentiometer
2	120/112183	Protection, Rectifier
3	120.113533	Potentiometer (470KA)
4	120.990178	Kit BCB Mog/Live Autom + Cable
5	120/120300	Cable 6mmq 1.8m
6	120/122256	Thermostat
7	120/122400	Switch, White Rocker
8	120/122752	Switch, Rocker Illuminated
--	120/132169	Mains Cable 3g1.5 2.3m (NOT SHOWN)
--	TG100/1	Flux Cored MIG Wire 0.9kg 0.9mm A5.20 Class E71T-GS (NOT SHOWN)
11	120/153023	Wire Feed Motor
12	120.169228	Reactance
--	TG100/4	Flux Cored MIG Wire 4.5kg 0.9mm A5.20 Class E71T-GS (NOT SHOWN)
14	B/609Z	Bearing 609Z
16	120/322126	Casing, Feeder Roller Shaft
17	120/322127	Casing, Torch Fixing
18	120/322128	Bracket, Counter Roller
19	120.322584	Front Panel
20	120.322586	Back Panel
21	120/422257	Knob, Counter Roller Tension
22	120/452022	Spring, Counter Roller Tension

Item	Part No.	Description
23	120.644959	Bottom (Black)
24	120.651015	Door
25	120/722529	Feed Roller 0.6-0.9mm Fluxcore
26	120.742270	Mig Torch 2MTR 130A
29	120/990097	Guide Hose 2mm x 4mm x 122mm
30	120/990286	Gear Set
31	120/990288	Reel Kit, 15-50mm
32	120.990746	Rectifier Kit
33	120/322172	Spindle, 15-50mm
34	120/322173	Reel Ring Nut
35	120/322174	Reel Thumb Screw
36	120/452065	Spring, Reel
37	120.322585	Fairleader
38	120/322143	Ring Nut, Cable Protection
39	120.990783	Cover Kit
40	120.990785	Diaphragm Kit
41	120.649424	Front Panel
42	120.644923	Back Panel
43	120.322587	Handle
44	120.322590	Handle
45	120/712001	Clamp, Earth (Black)
46	120.322112	Bushing

**NOTE:** It is our policy to continually improve products and as such we reserve the right to alter data, specifications and component parts without prior notice.

**IMPORTANT:** No liability is accepted for incorrect use of product.

**WARRANTY:** Guarantee is 12 months from purchase date, proof of which will be required for any claim.

**Sealey Group**, Kempson Way, Suffolk Business Park, Bury St Edmunds, Suffolk. IP32 7AR



01284 757500



01284 703534



sales@sealey.co.uk



www.sealey.co.uk



Parts Information:  
No-Gas MIG Welder 90Amp 230V  
Model No: PMG100.V2

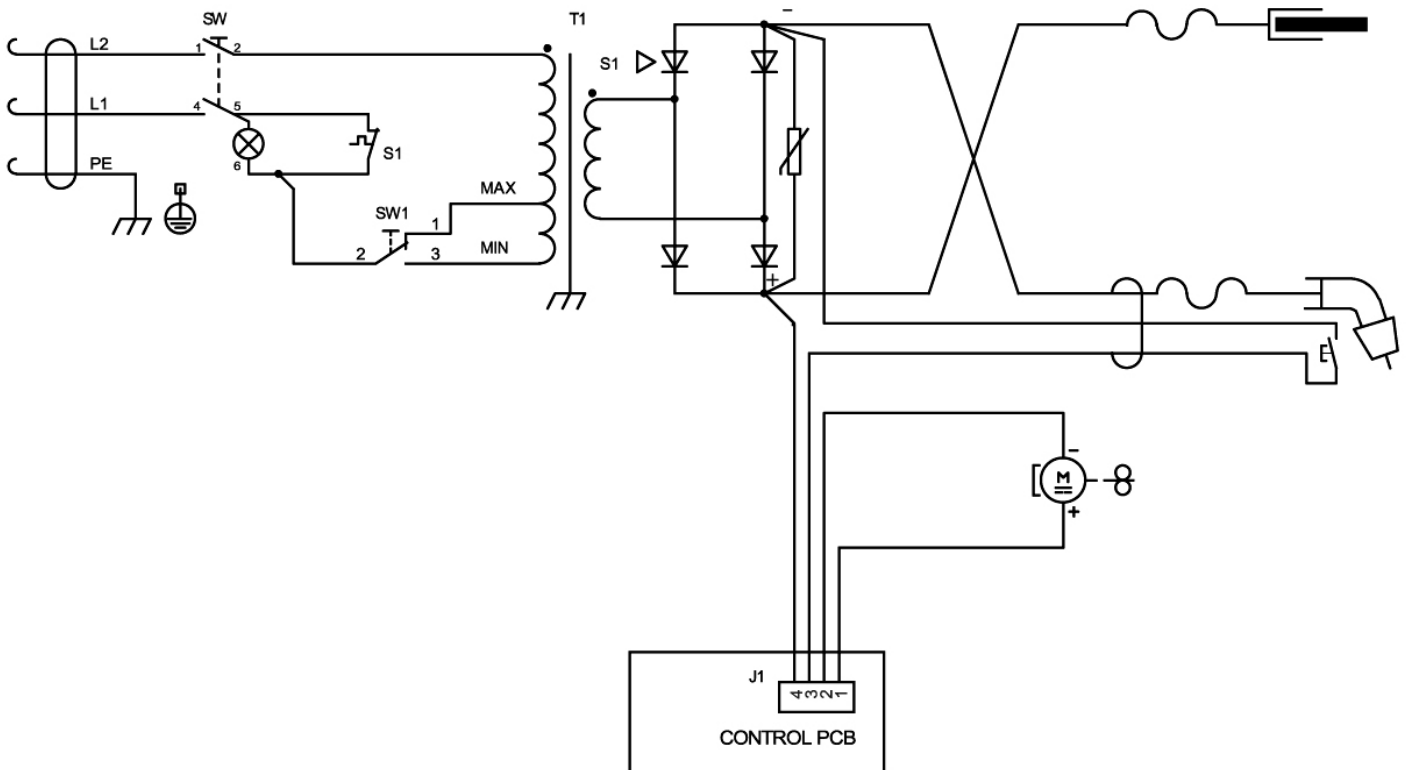
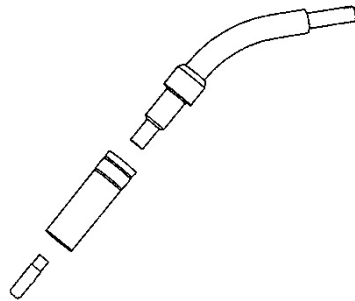
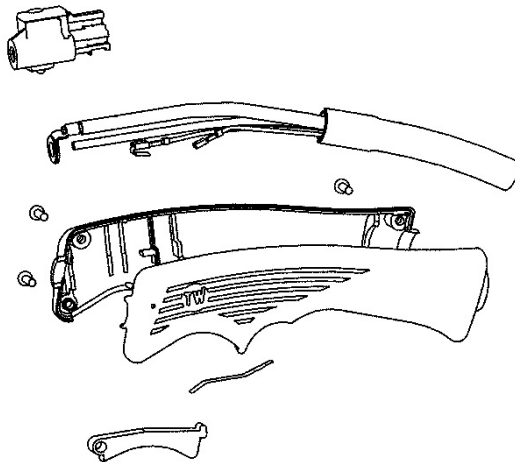

**NOTE:** It is our policy to continually improve products and as such we reserve the right to alter data, specifications and component parts without prior notice.

**IMPORTANT:** No liability is accepted for incorrect use of product.

**WARRANTY:** Guarantee is 12 months from purchase date, proof of which will be required for any claim.

Sealey Group, Kempson Way, Suffolk Business Park, Bury St Edmunds, Suffolk. IP32 7AR



01284 757500



01284 703534



sales@sealey.co.uk



www.sealey.co.uk