

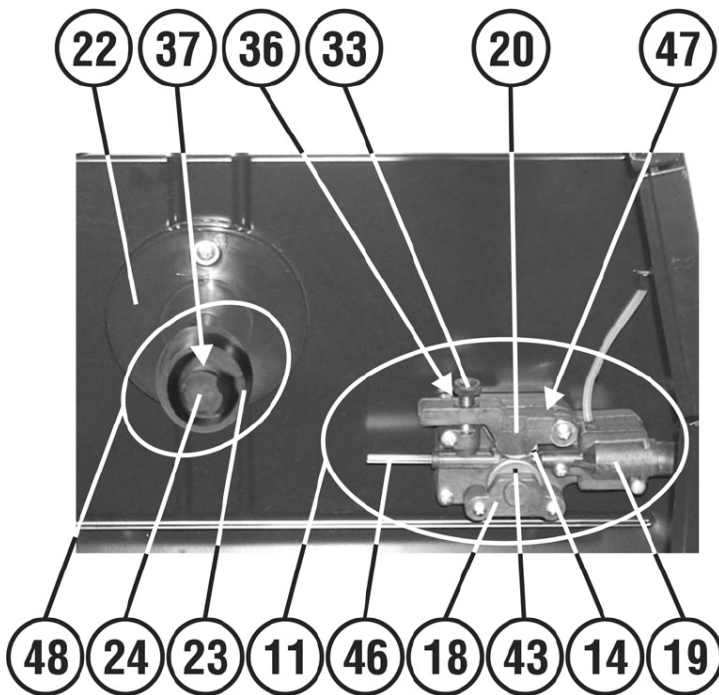

Parts Information:
MIG Welder 150Amp 230V
Model No: PM150XT.V2

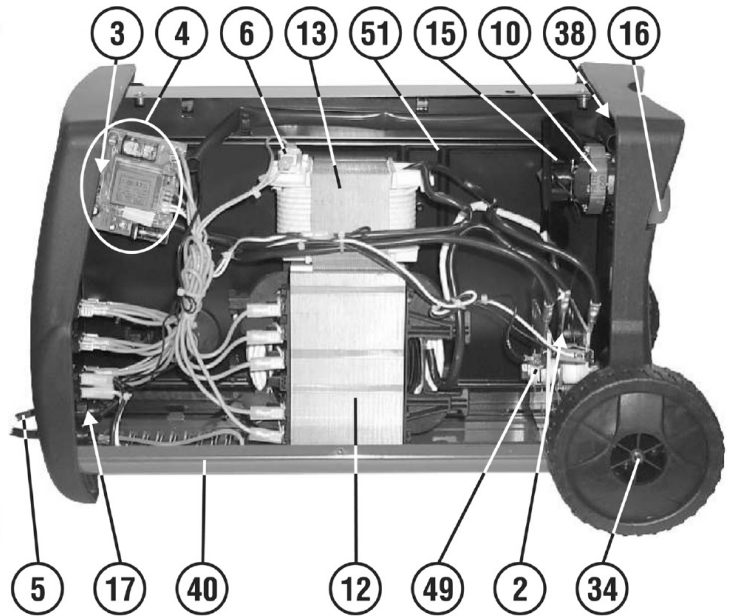

NOTE: It is our policy to continually improve products and as such we reserve the right to alter data, specifications and component parts without prior notice.

IMPORTANT: No liability is accepted for incorrect use of product.

WARRANTY: Guarantee is 12 months from purchase date, proof of which will be required for any claim.

Sealey Group, Kempson Way, Suffolk Business Park, Bury St Edmunds, Suffolk. IP32 7AR



01284 757500



01284 703534



sales@sealey.co.uk



www.sealey.co.uk



Parts Information:
MIG Welder 150Amp 230V
Model No: PM150XT.V2

Item	Part No.	Description
1	120.121424	Knob, Potentiometer
2	120/112183	Protection, Rectifier
3	120.113386	Potentiometer
4	120.980463	Wire Feed Control Card
5	CC10/1	10mm Copper Cable Per Metre
6	120.121069	Thermostat 15A 250V
7	120/122400	Switch, White Rocker
8	120/122752	Switch, Rocker Illuminated
9	120/132306	Main cable (use mc3cx1.5)
10	120/152080	Motor, Electrofan
11	120/153900	Wire Feed + Torch Fixing Kit
12	120.990813	Transformer
13	120.169228	Reactance
14	B/609Z	Bearing 609Z
15	120/312026	Blade, Fan
16	120/322104	Belt For Bottle
17	120.322112	Bushing
18	120/322126	Casing, Feeder Roller Shaft
19	120/322127	Casing, Torch Fixing
20	120/322128	Bracket, Counter Roller
21	120/322143	Ring Nut, Cable Protection
22	120/322172	Spindle, 15-50mm
23	120/322173	Reel Ring Nut
24	120/322174	Reel Thumb Screw
25	120/322193	Wheel
26	120/322223	Cap, Axle
27	120.322584	Front Panel

Item	Part No.	Description
28	120.322585	Fairleader
29	120.322588	Handle
30	120.322589	Handle
31	120.322590	Handle
32	120.322595	Back Panel
33	120/422257	Knob, Counter Roller Tension
34	120/422961	Axle 345mm x 8mm
36	120/452022	Spring, Counter Roller Tension
37	120/452065	Spring, Reel
38	120.644918	Back Panel
39	120.649420	Front Panel
40	120.644960	Bottom (Black)
41	120.651018	Door
42	120/712001	Clamp, Earth (Black)
43	120/722019	Feed Roller 0.6-0.8/0.9mm
44	REG/MM	MIG Gas Regulator Disposable Cylinder No Gauge
45	120.742901	Mig Torch
46	120/990097	Guide Hose 2mm x 4mm x 122mm
47	120/990251	Gear Set
48	120/990288	Reel Kit, 15-50mm
49	120.990745	Rectifier Kit
50	120.990784	Cover Kit
51	120.990787	Diaphragm Kit
--	120/802545	Welding Mask (NOT SHOWN)
--	120.712257	Welding Lens (107x51mm Glass) (NOT SHOWN)
--	120.980389	Throw Away Bottle Connection Kit (NOT SHOWN)

NOTE: It is our policy to continually improve products and as such we reserve the right to alter data, specifications and component parts without prior notice.

IMPORTANT: No liability is accepted for incorrect use of product.

WARRANTY: Guarantee is 12 months from purchase date, proof of which will be required for any claim.

Sealey Group, Kempson Way, Suffolk Business Park, Bury St Edmunds, Suffolk. IP32 7AR



01284 757500



01284 703534



sales@sealey.co.uk



www.sealey.co.uk

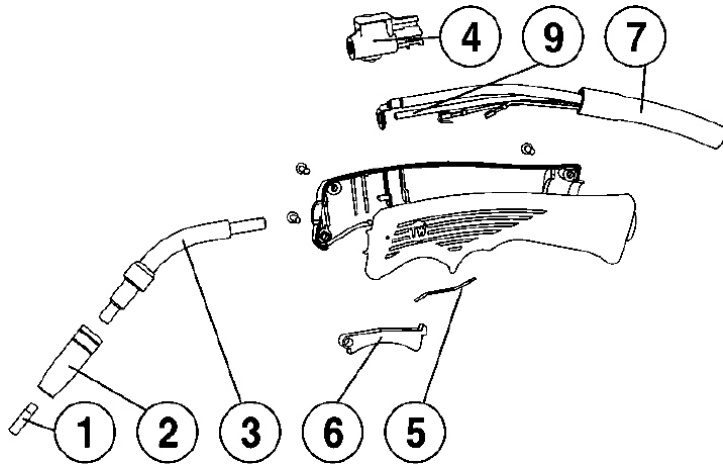

Item	Part No.	Description
1	MIG957	Contact Tip 0.8mm TB15 Pack Of 5
2	MIG955	Conical Nozzle TB15 Pack Of 3
3	120/722078	Lance With Diffuser
4	120/990464	Torch Connection Assembly

Item	Part No.	Description
5	120/452097	Contact Spring
6	120/322295	Pushbutton
7	120/990600	Sleeve With Cable
9	120/742412	Liner, Black, 0.6-0.8mm 2.25m

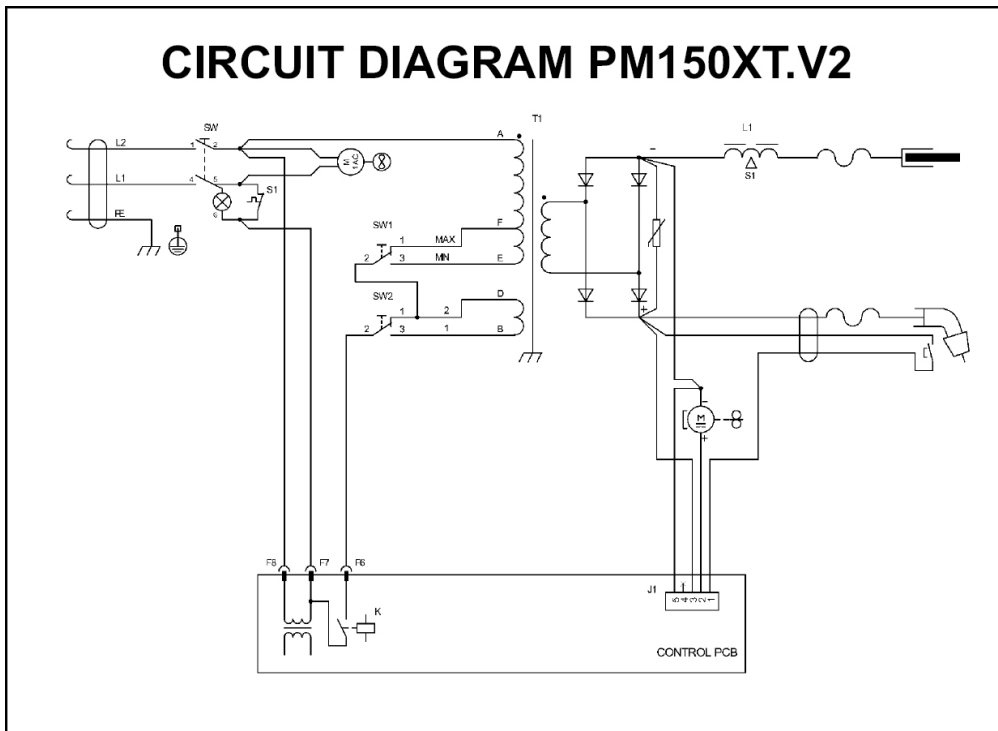

NOTE: It is our policy to continually improve products and as such we reserve the right to alter data, specifications and component parts without prior notice.

IMPORTANT: No liability is accepted for incorrect use of product.

WARRANTY: Guarantee is 12 months from purchase date, proof of which will be required for any claim.