

NOTE: It is our policy to continually improve products and as such we reserve the right to alter data, specifications and component parts without prior notice.

IMPORTANT: No liability is accepted for incorrect use of product.

WARRANTY: Guarantee is 12 months from purchase date, proof of which will be required for any claim.



Parts Information:
MIG Welder 150Amp 230V
Model No: PM150XT

Item	Part No.	Description
1	120/112363	Potentiometer
2	120.121424	Knob, Potentiometer
3	120/112185	Protection, Rectifier
4	120/112074	Rectifier
5	120.980463	Wire Feed Control Card
6	120/122525	Thermostat
7	120/122400	Switch, White Rocker
8	120/122752	Switch, Rocker Illuminated
9	LS/16	Lead (Single) 16mm 3m C/W Eyes
11	120/152080	Motor, Electrofan
12	120/153900	Wire Feed + Torch Fixing Kit
13	120/164139	Reactance
14	120/164343	Transformer
15	B/609Z	Bearing 609Z
16	120/322104	Belt For Bottle
17	120/322126	Casing, Feeder Roller Shaft
18	120/322127	Casing, Torch Fixing
19	120/322128	Bracket, Counter Roller
20	120/322172	Spindle, 15-50mm
21	120/322173	Reel Ring Nut
22	120/322174	Reel Thumb Screw
23	120/322193	Wheel
24	120/322443	Panel, Front (3 Switch Holes)
25	120/322447	Panel, Rear

Item	Part No.	Description
26	120/312026	Blade, Fan
27	120/422257	Knob, Counter Roller Tension
28	120/422485	Holder, Bottle
--	120/BSP	Bottle Support Plate (NOT SHOWN)
29	120/422487	Handle
30	120/422945	Axle, Wheels
31	120/452022	Spring, Counter Roller Tension
32	120/452065	Spring, Reel
33	120/422509	Handle
34	120/644066	Bottom
35	120/650041	Door
36	120/650005	Panel, Side
38	120/712001	Clamp, Earth (Black)
40	120/722019	Feed Roller 0.6-0.8/0.9mm
41	120.742901	Mig Torch
44	120/990097	Guide Hose 2mm x 4mm x 122mm
--	120/990251	Gear Set (NOT SHOWN)
--	120/990288	Reel Kit, 15-50mm (NOT SHOWN)
49	120/122527	Fuse (Glass 1.5Amp 250V 5x20)
51	REG/MM	MIG Gas Regulator Disposable Cylinder No Gauge / MIG Gas Reg
--	370/098	Circlip, 8 E (NOT SHOWN)
--	120/802545	Welding Mask (NOT SHOWN)
--	120.712257	Welding Lens (107x51mm Glass) (NOT SHOWN)

NOTE: It is our policy to continually improve products and as such we reserve the right to alter data, specifications and component parts without prior notice.

IMPORTANT: No liability is accepted for incorrect use of product.

WARRANTY: Guarantee is 12 months from purchase date, proof of which will be required for any claim.

Sealey Group, Kempson Way, Suffolk Business Park, Bury St Edmunds, Suffolk. IP32 7AR



01284 757500



01284 703534



sales@sealey.co.uk



www.sealey.co.uk

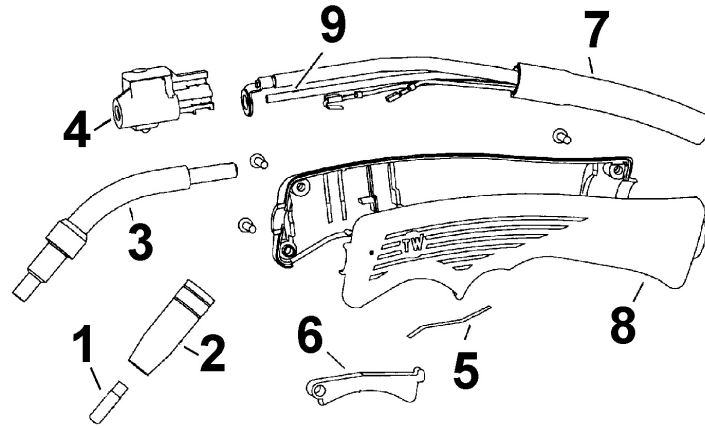

Item	Part No.	Description
1	MIG956	Contact Tip 0.6mm TB15 Pack Of 4
2	MIG955	Conical Nozzle TB15 Pack Of 3
3	120/722078	Lance With Diffuser
4	120/990464	Torch Connection Assembly
5	120/452097	Contact Spring
6	120/322295	Pushbutton
7	120/990600	Sleeve With Cable
8	120/990465	Handle, Complete

Item	Part No.	Description
9	120/722047	Liner, Black 0.6-0.8mm 2.2M
--	120/722050NEV	Liner, White, Gas For Torch (No Electro-Valve)3.2M (NOT SHOWN)
--	120/722078	Lance With Diffuser (NOT SHOWN)
--	168.200162	Spot Welding Nozzle TB15 Single (NOT SHOWN)
--	MIG957	Contact Tip 0.8mm TB15 Pack Of 5 (NOT SHOWN)

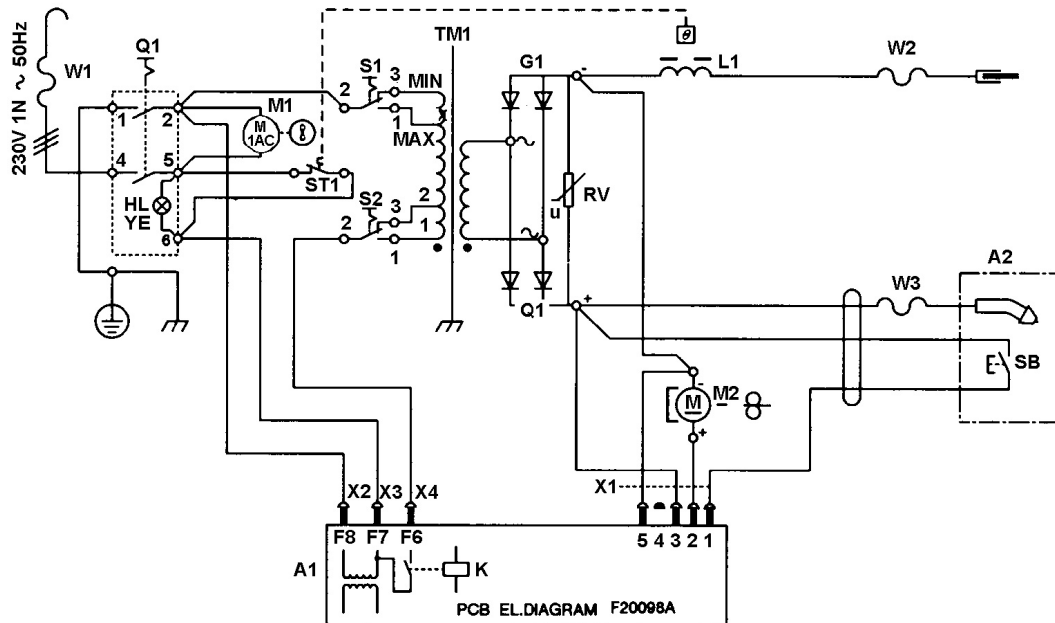

NOTE: It is our policy to continually improve products and as such we reserve the right to alter data, specifications and component parts without prior notice.

IMPORTANT: No liability is accepted for incorrect use of product.

WARRANTY: Guarantee is 12 months from purchase date, proof of which will be required for any claim.