

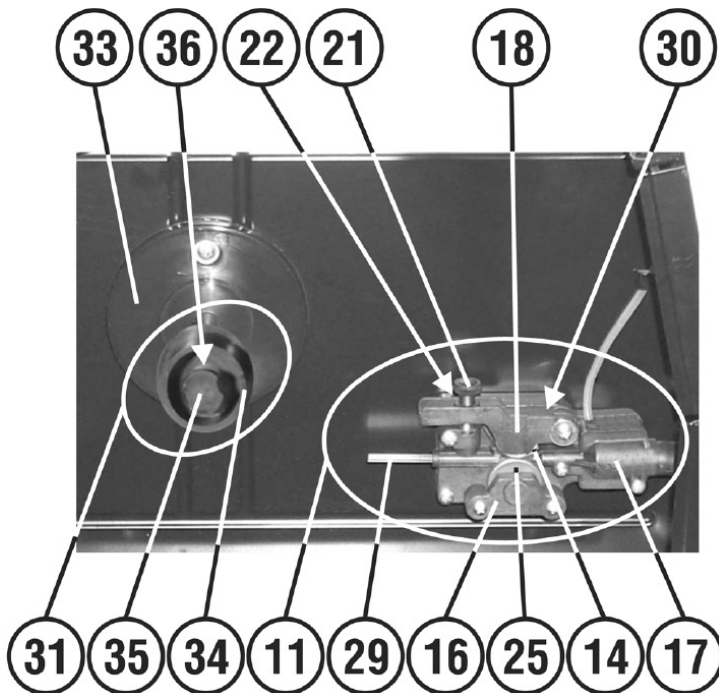

Parts Information:
MIG Welder 140Amp 230V
Model No: PM140XT.V2

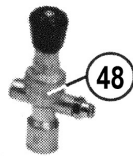
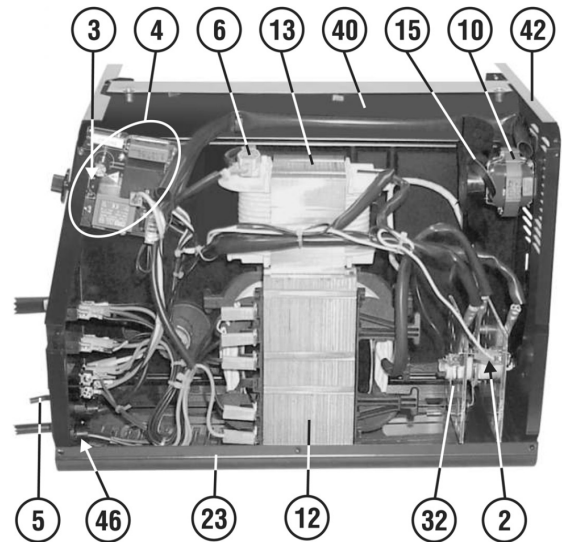
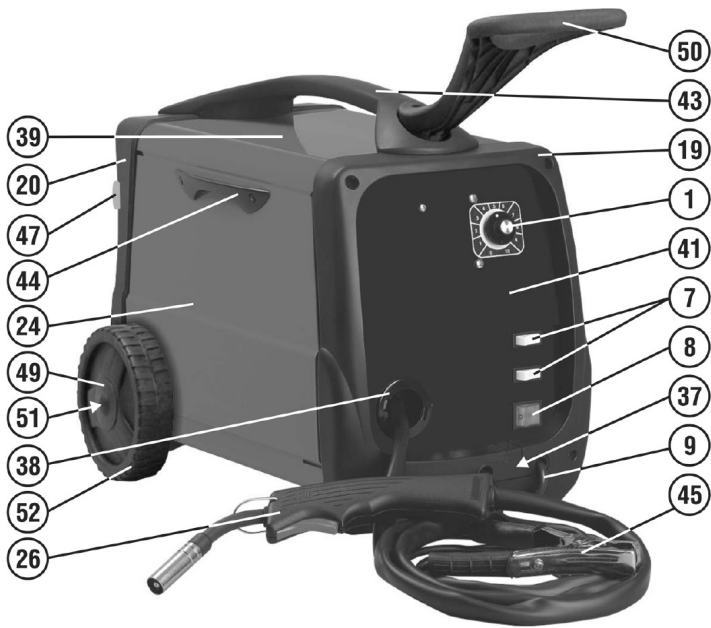

NOTE: It is our policy to continually improve products and as such we reserve the right to alter data, specifications and component parts without prior notice.

IMPORTANT: No liability is accepted for incorrect use of product.

WARRANTY: Guarantee is 12 months from purchase date, proof of which will be required for any claim.

Sealey Group, Kempson Way, Suffolk Business Park, Bury St Edmunds, Suffolk. IP32 7AR



01284 757500



01284 703534



sales@sealey.co.uk



www.sealey.co.uk



Parts Information:
MIG Welder 140Amp 230V
Model No: PM140XT.V2

Item	Part No.	Description
1	120.121424	Knob, Potentiometer
2	120/112183	Protection, Rectifier
3	120/112079	Potentiometer 10K
4	120.980463	Wire Feed Control Card
5	CC10/1	10mm Copper Cable Per Metre
6	120.121069	Thermostat 15A 250V
7	120/122400	Switch, White Rocker
8	120/122752	Switch, Rocker Illuminated
9	120/132169	Mains Cable 3g1.5 2.3m
10	120/152080	Motor, Electrofan
11	120/153900	Wire Feed + Torch Fixing Kit
12	120.990812	Transformer
13	120.169247	Reactance
14	B/609Z	Bearing 609Z
15	120/312026	Blade, Fan
16	120/322126	Casing, Feeder Roller Shaft
17	120/322127	Casing, Torch Fixing
18	120/322128	Bracket, Counter Roller
19	120.322584	Front Panel
20	120.322595	Back Panel
21	120/422257	Knob, Counter Roller Tension
22	120/452022	Spring, Counter Roller Tension
23	120.644962	Bottom (Black)
24	120.651021	Door
25	120/722019	Feed Roller 0.6-0.8/0.9mm
26	120/742900	Mig Torch 3MTR
29	120/990097	Guide Hose 2mm x 4mm x 122mm

Item	Part No.	Description
30	120/990251	Gear Set
31	120/990288	Reel Kit, 15-50mm
32	120.990746	Rectifier Kit
33	120/322172	Spindle, 15-50mm
34	120/322173	Reel Ring Nut
35	120/322174	Reel Thumb Screw
36	120/452065	Spring, Reel
37	120.322585	Fairleader
38	120/322143	Ring Nut, Cable Protection
39	120.990783	Cover Kit
40	120.990785	Diaphragm Kit
41	120.649423	Front Panel
42	120.644918	Back Panel
43	120.322587	Handle
44	120.322590	Handle
45	120/712001	Clamp, Earth (Black)
46	120.322112	Bushing
47	120/322104	Belt For Bottle
48	REG/MM	MIG Gas Regulator Disposable Cylinder No Gauge
49	120/322223	Cap, Axle
50	120.322589	Handle
51	120/422961	Axle 345mm x 8mm
52	120/322193	Wheel
--	120/802545	Welding Mask (NOT SHOWN)
--	120.712257	Welding Lens (107x51mm Glass) (NOT SHOWN)
--	120/722050	Liner, White, Gas For Torch 2.75m (NOT SHOWN)

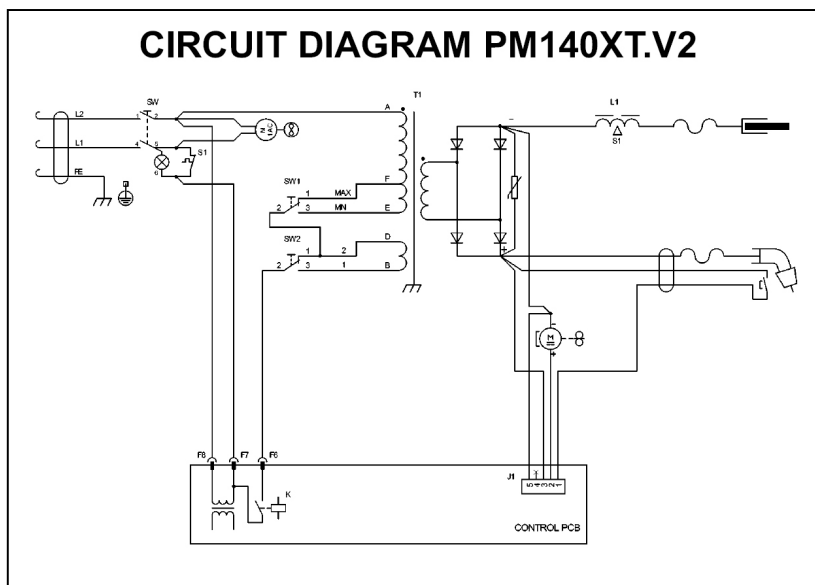

NOTE: It is our policy to continually improve products and as such we reserve the right to alter data, specifications and component parts without prior notice.

IMPORTANT: No liability is accepted for incorrect use of product.

WARRANTY: Guarantee is 12 months from purchase date, proof of which will be required for any claim.

Sealey Group, Kempson Way, Suffolk Business Park, Bury St Edmunds, Suffolk. IP32 7AR



01284 757500



01284 703534



sales@sealey.co.uk



www.sealey.co.uk