

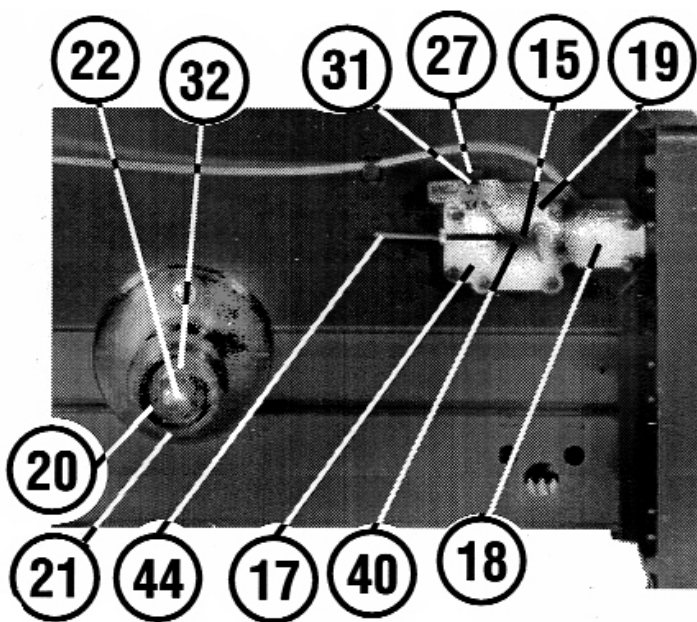

Parts Information:  
MIG Welder 140Amp 230V  
Model No: PM140XT

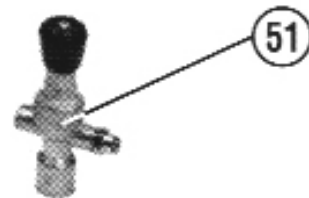
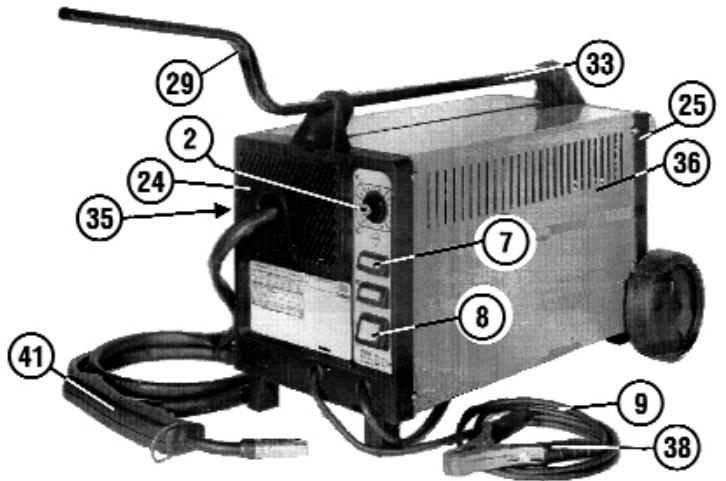
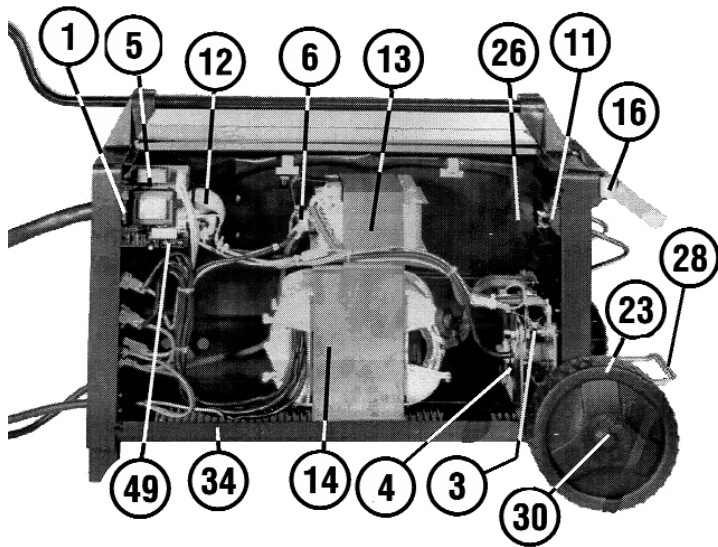

**NOTE:** It is our policy to continually improve products and as such we reserve the right to alter data, specifications and component parts without prior notice.

**IMPORTANT:** No liability is accepted for incorrect use of product.

**WARRANTY:** Guarantee is 12 months from purchase date, proof of which will be required for any claim.

Sealey Group, Kempson Way, Suffolk Business Park, Bury St Edmunds, Suffolk. IP32 7AR



01284 757500



01284 703534



sales@sealey.co.uk



www.sealey.co.uk



Parts Information:  
**MIG Welder 140Amp 230V**  
**Model No: PM140XT**

Item	Part No.	Description
1	120/112363	Potentiometer
2	120.121424	Knob, Potentiometer
3	120/112185	Protection, Rectifier
4	120/112072	Rectifier (PMS-8/2/125)
5	120.980463	Wire Feed Control Card
6	120/122525	Thermostat
7	120/122400	Switch, White Rocker
8	120/122379	Switch, Red, Rocker Type
9	CC10/1	10mm Copper Cable Per Metre
--	120/132169	Mains Cable 3G1.5 2.3M
11	120/152080	Motor, Electrofan
12	120/153900	Wire Feed + Torch Fixing Kit
13	120/164131	Reactance
14	120/164341	Transformer, 230V
15	B/609Z	Bearing 609Z
16	120/322104	Belt For Bottle
17	120/322126	Casing, Feeder Roller Shaft
18	120/322127	Casing, Torch Fixing
19	120/322128	Bracket, Counter Roller
20	120/322172	Spindle, 15-50mm
21	120/322173	Reel Ring Nut
22	120/322174	Reel Thumb Screw
23	120/322193	Wheel
24	120/322443	Panel, Front (3 Switch Holes)
25	120/322447	Panel, Rear

Item	Part No.	Description
26	120/312026	Blade, Fan
27	120/422257	Knob, Counter Roller Tension
28	120/422485	Holder, Bottle
29	120/422487	Handle
30	120/422960	Axle
31	120/452022	Spring, Counter Roller Tension
32	120/452065	Spring, Reel
33	120/422497	Handle
34	120/644771	Panel, Bottom
35	120/650040	Door
36	120/650004	Panel, Side
38	120/712001	Clamp, Earth (Black)
40	120/722019	Feed Roller 0.6-0.8/0.9mm
41	120/742900	Mig Torch 3MTR
44	120/990097	Guide Hose 2mm x 4mm x 122mm
--	120/990251	Gear Set (NOT SHOWN)
--	120/990288	Reel Kit, 15-50mm (NOT SHOWN)
49	120/122879	Fuse (Glass T1.6Amp 250V 5x20)
51	REG/MM	MIG Gas Regulator Disposable Cylinder No Gauge / MIG Gas Reg
--	370/098	Circlip, 8 E (NOT SHOWN)
--	120/802545	Welding Mask (NOT SHOWN)
--	120.712257	Welding Lens (107x51mm Glass) (NOT SHOWN)
--	120/802395	Steel Wire Coil 0.6mm 5KG (NOT SHOWN)
--	120/802396	Steel Wire Coil 0.8mm 5KG (NOT SHOWN)

**NOTE:** It is our policy to continually improve products and as such we reserve the right to alter data, specifications and component parts without prior notice.

**IMPORTANT:** No liability is accepted for incorrect use of product.

**WARRANTY:** Guarantee is 12 months from purchase date, proof of which will be required for any claim.

**Sealey Group**, Kempson Way, Suffolk Business Park, Bury St Edmunds, Suffolk. IP32 7AR



01284 757500



01284 703534



sales@sealey.co.uk



www.sealey.co.uk

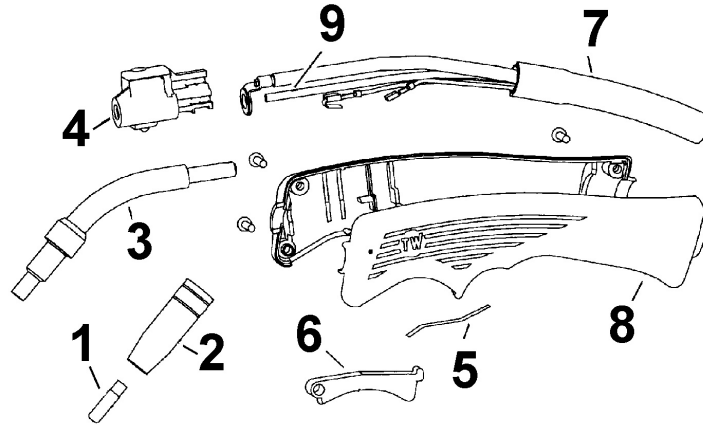

Item	Part No.	Description
1	MIG952	Contact Tip 0.8mm TB14 Pack Of 5
2	MIG950	Conical Nozzle TB14 Pack Of 5
3	120/722810	Swan Neck (Mightymig & PM)
4	120/990464	Torch Connection Assembly
5	120/452097	Contact Spring

Item	Part No.	Description
6	120/322295	Pushbutton
7	120/990600	Sleeve With Cable
8	120/990465	Handle, Complete
9	120/742412	Liner, Black, 0.6-0.8mm 2.25M

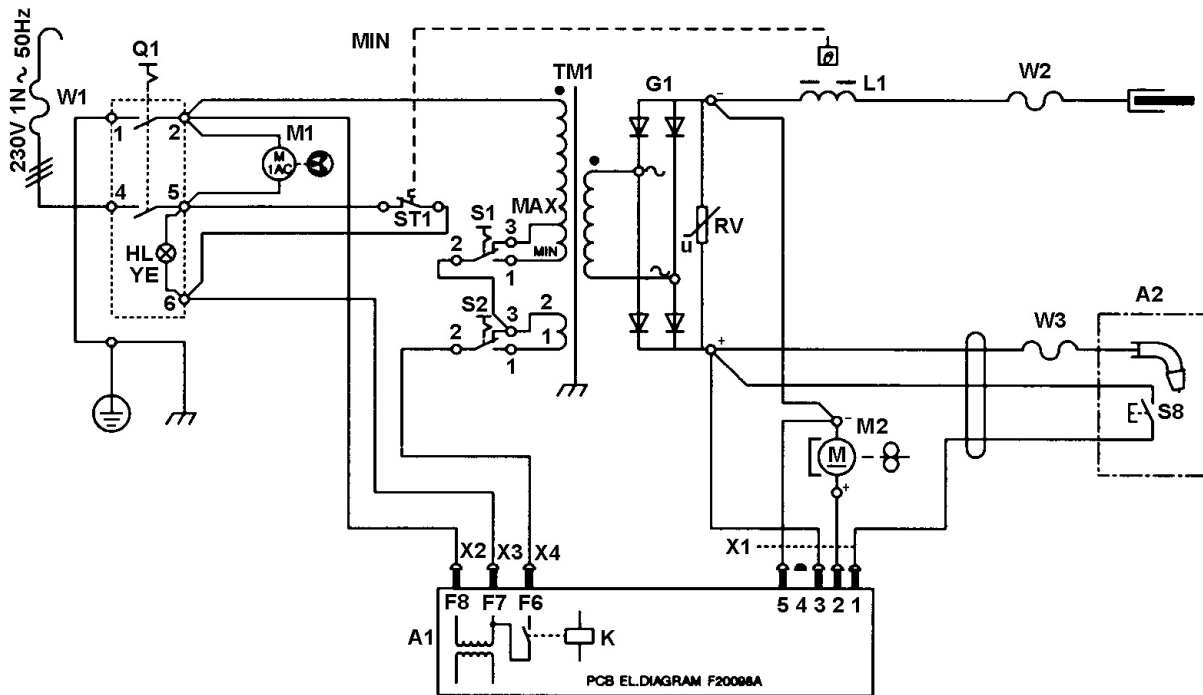

**NOTE:** It is our policy to continually improve products and as such we reserve the right to alter data, specifications and component parts without prior notice.

**IMPORTANT:** No liability is accepted for incorrect use of product.

**WARRANTY:** Guarantee is 12 months from purchase date, proof of which will be required for any claim.