

Parts Information:  
**Pillar Drill Bench Premier Digital Variable  
 Speed 1000mm Height 500W/230V  
 Model No: PDME160B**

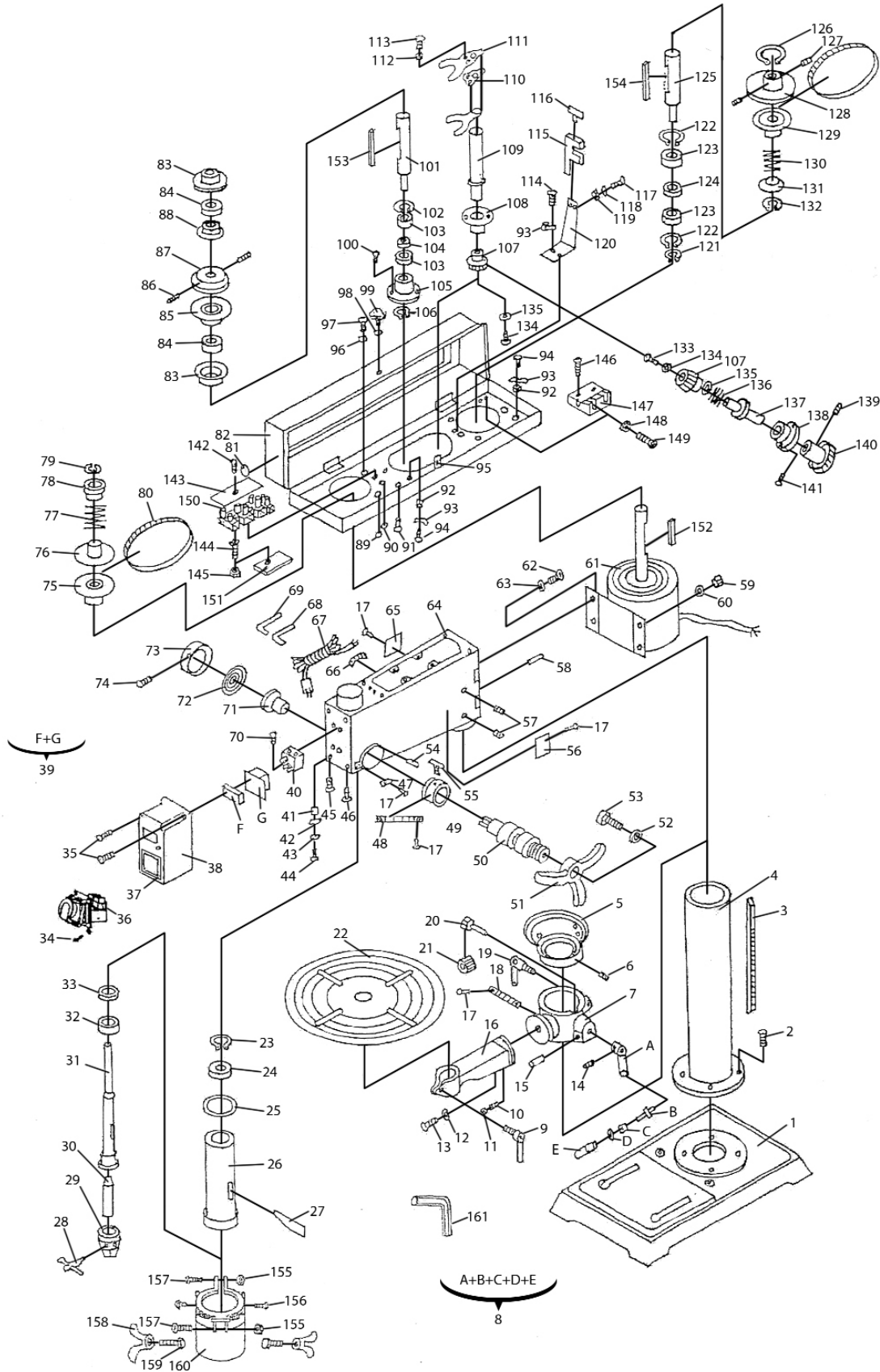

**NOTE:** It is our policy to continually improve products and as such we reserve the right to alter data, specifications and component parts without prior notice.

**IMPORTANT:** No liability is accepted for incorrect use of product.

**WARRANTY:** Guarantee is 12 months from purchase date, proof of which will be required for any claim.



Parts Information:  
**Pillar Drill Bench Premier Digital Variable  
 Speed 1000mm Height 500W/230V  
 Model No: PDME160B**

Item	Part No.	Description
1	PDME160B.01	Base
2	PDME160B.02	Bolt M10x40 C/W Washer
3	PDME160B.03	Rack
4	PDME160B.04	Column
5	PDME160B.05	Collar
6	PDME160B.06	Screw
7	PDME160B.07	Table Support Seat
8	PDME160B.08	Crank (Parts 08-12)
9	PDME160B.13	Lock Handle
10	PDME160B.14	Pin
11	SN6.SB	Steel Nut M6 Black (Single)
12	PDME160B.16	Flat Washer
13	PDME160B.17	Bolt M16x40
14	PDME160B.18	Screw
15	PDME160B.19	Gear Pin
16	PDME160B.20	Table Support
17	PDME160B.21	Rivet
18	PDME160B.22	Indicator
19	PDME160B.23	Lock Handle
20	PDME160B.24	Worm
21	PDME160B.25	Gear
22	PDME160B.26	Table
23	PDME160B.27	Retaining Ring
24	B/6203-2RS	Bearing 6203-2RS
25	PDME160B.29	Rubber Washer
26	PDME160B.30	Spindle Sleeve
27	PDME160B.31	Wedge
28	PDME160B.32	Chuck Key
29	GDM92B/20	Chuck B16 3-16mm
30	PDME160B.34	Arbor
31	PDME160B.35	Spindle
32	PDME160B.36	Bearing 801S
33	B/6205ZZ	Bearing 6205ZZ
34	PDME160B.38	Screw
35	PDME160B.39	Phillips Bolt M6x12
36	PDME160B.40	Switch
37	PDME160B.41	Plastic Plate
38	PDME160B.42	Switch Box
39	PDME160B.43	Digital Display Sets (43-44)
40	PDME160B.45	Terminal
41	PDME160B.46	Copper

Item	Part No.	Description
42	PDME160B.47	Grounding Mark
43	PDME160B.48	Star Washer
44	PDME160B.49	Screw
45	PDME160B.50	Screw
46	PDME160B.51	Screw
47	PDME160B.52	Indicator
48	PDME160B.53	Scale
49	PDME160B.54	Depth Stop Collar
50	PDME160B.55	Gear Shaft
51	PDME160B.56	Feed Handle (Cast Iron)
52	PDME160B.57	Check Ring
53	SCB825.SB	Socket Head Cap Screw M8x25 Black
54	PDME160B.58	Stop Pin
55	PDME160B.59	Depth Lock Screw
56	PDME160B.60	Warning Label
57	PDME160B.61	Screw
58	PDME160B.62	Stop Pin
59	SN8.SB	Steel Nut M8 Black (Single)
60	PDME160B.64	Spring Washer
61	PDME160B.65	Motor
--	PDME200F.02	Capacitor Cover (NOT SHOWN)
62	PDME160B.66	Phillips Bolt M6x16.
63	PDME160B.67	Plate Washer
64	PDME160B.68	Head
65	PDME160B.69	Label
66	PDME160B.70	Speed Range Label
67	PDME160B.71	Cable
68	PDME160B.72	Allen Key
69	PDME160B.73	Allen Key
70	PDME160B.74	Screw
71	PDME160B.75	Spring Seat
72	PDME160B.76	Spring
73	PDME160B.77	Spring Cover
74	PDME160B.78	Screw
75	PDME160B.79	Fixed Pulley (Motor)
76	PDME160B.80	Movable Pulley (Motor)
77	PDME160B.81	Spring
78	PDME160B.82	Steel Seat
79	PDME160B.83	Snap Ring
80	PDME160B.84	Belt,Ribbed (ID-515)

**NOTE:** It is our policy to continually improve products and as such we reserve the right to alter data, specifications and component parts without prior notice.

**IMPORTANT:** No liability is accepted for incorrect use of product.

**WARRANTY:** Guarantee is 12 months from purchase date, proof of which will be required for any claim.

**Sealey Group**, Kempson Way, Suffolk Business Park, Bury St Edmunds, Suffolk. IP32 7AR



01284 757500



01284 703534



sales@sealey.co.uk



www.sealey.co.uk



Parts Information:  
**Pillar Drill Bench Premier Digital Variable  
 Speed 1000mm Height 500W/230V  
 Model No: PDME160B**

Item	Part No.	Description
81	PDME160B.85	Label
82	PDME160B.86	Pulley Cover
83	PDME160B.87	Bearing Seat
84	B/6005-2RS	Bearing 6005-2RS
85	PDME160B.89	Lower Movable Pulley (Middle)
86	PDME160B.90	Screw
87	PDME160B.91	Fixed Pulley (Middle)
88	PDME160B.92	Upper Movable Pulley (Middle)
89	PDME160B.93	Rubber Washer
90	PDME160B.94	Rubber Washer
91	PDME160B.95	Strain Relief
92	MG3143.V2-44	Hex Nut
93	PDME160B.97	Cable Clamp
94	PDME160B.98	Screw
95	PDME160B.99	Latch
96	PDME160B.100	Flat Washer
97	PDME160B.101	Screw
98	PDME160B.102	Flat Washer
99	PDME160B.103	Screw
100	PDME160B.104	Screw
101	PDME160B.105	Middle Shaft
102	PDME160B.106	Retaining Ring
103	B/6002-2RS	Bearing 6002-2RS
104	PDME160B.108	Bushing
105	PDME160B.109	Bearing Seat
106	PDME160B.110	Retaining Ring
107	PDME160B.111	Gear Wheel
108	PDME160B.112	Steel Seat
109	PDME160B.113	Screw Thread Shaft
110	PDME160B.114	Lower Ford
111	PDME160B.115	Upper Ford
112	PDME160B.116	Spring Washer
113	PDME160B.117	Pan Head Screw
114	PDME160B.118	Pan Head Screw
115	PDME160B.119	Plastic Seat
116	PDME160B.120	Sensor
117	PDME160B.121	Screw
118	PDME160B.122	Flat washer
119	SN4.SB	Steel Nut M4 Black (Single)
120	PDME160B.124	Sensor Support
121	PDME160B.125	Retaining Ring

Item	Part No.	Description
122	PDME160B.126	Retaining Ring
123	B/6204-2RS	Bearing 6204-2RS
124	PDME160B.128	Bushing
125	PDME160B.129	Shaft
126	PDME160B.130	Retaining Spring
127	PDME160B.131	Hexagon Socket Screw
128	PDME160B.132	Fixed Pulley (Spindle)
129	PDME160B.133	Movable Pulley (Spindle)
130	PDME160B.134	Spring
131	PDME160B.135	Spring Seat
132	PDME160B.136	Retaining Spring
133	PDME160B.137	Screw
134	PDME160B.138	Flat Washer
135	PDME160B.139	Flat Washer
136	PDME160B.140	Spring
137	PDME160B.141	Shaft
138	PDME160B.142	Flange Plate
139	PDME160B.143	Hex Socket Screw
140	PDME160B.144	Adjust Wheel
141	PDME160B.145	Screw
142	PDME160B.146	Self Tapping Screw
143	PDME160B.147	Cover
144	PDME160B.148	Cross Pan Head Screw
145	PDME160B.149	Nut
146	PDME160B.150	Self Tapping Screw
147	PDME160B.151	Micro Switch
148	SN4.SB	Steel Nut M4 Black (Single)
149	PDME160B.153	Cross Pan Head Screw
150	PDME160B.154	Terminal
151	PDME160B.155	Plate
152	PDME160B.156	Woodruff Key
153	PDME160B.157	Woodruff Key
154	PDME160B.158	Woodruff Key
155	SN4.S	Steel Nut M4 Zinc Din934 (Single)
156	PDME160B.160	Self Tapping Screw
157	PDME160B.161	Cross Pan Head Screw
158	PDME160B.162	Flange Nut
159	PDME160B.163	Phillips Bolt M4x22
160	DPG99	Drill Press Guard 60mm
161	PDME160B.165	Allen Key

**NOTE:** It is our policy to continually improve products and as such we reserve the right to alter data, specifications and component parts without prior notice.

**IMPORTANT:** No liability is accepted for incorrect use of product.

**WARRANTY:** Guarantee is 12 months from purchase date, proof of which will be required for any claim.

**Sealey Group**, Kempson Way, Suffolk Business Park, Bury St Edmunds, Suffolk. IP32 7AR



01284 757500



01284 703534



sales@sealey.co.uk



www.sealey.co.uk