

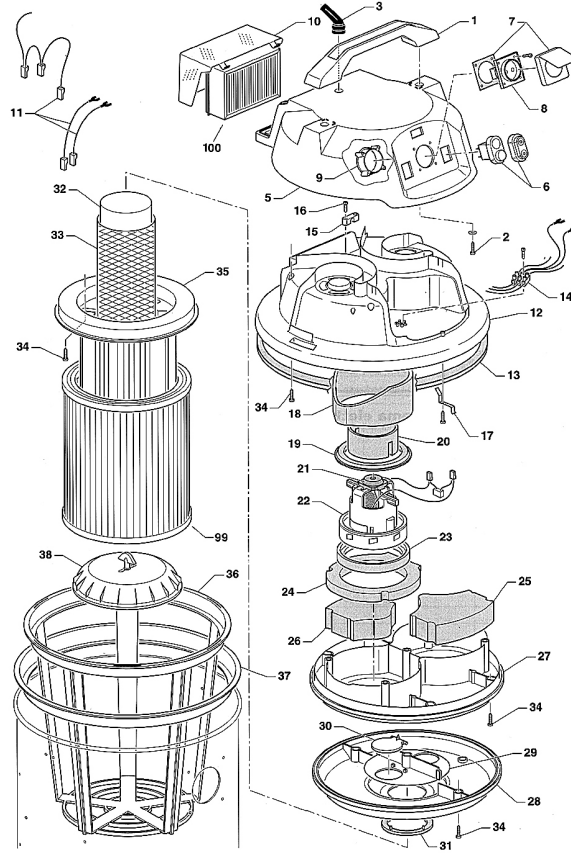

Parts Information:
**Vacuum Cleaner Industrial Wet &
 Dry Twin Motor 90ltr Stainless Drum
 1200/2400W/230V with Pump
 Model No: PC90P**



Item	Part No.	Description
1	186.50003H00	Handle
2	186.25805H0X	Screw 4.5x40mm
3	186.70004H0N	Cable Guide
--	186.80017BON	Feeder (NOT SHOWN)
5	186.50009H00	Cover
6	186.80100H0V	TTR Bipolar Switch
7	186.80202B8N	Gasket/Socket Cover
8	186.80200B8N	Tripolar Socket
9	186/50315BDV	Nut, Lock
10	186.50007H00	Hepa Post Filter Lid
11	186.80150H0V	Set Of Wires
12	186.50006H0G	Motor Cover
13	186.70007H0N	Lid Gasket
14	186/80029BOI	Terminal
15	186/50333BEN	Fastener, Cable
16	186.25806H0X	Screw 3.5x20mm
17	186.30078H0X	Contact
18	186.83350H0N	Exterior Isolator Ring To Motor Diaphragm
19	186.70001H0N	Diaphragm Seal

Item	Part No.	Description
20	186.70000H0N	Flow Separator
21	186.70005H0N	Motor Absorber
22	186.20100H0X	Motor (Single Stage W/Cup) (Internal 240V 50/60hz)
23	186.70002H0N	Motor Gasket
24	186.83351H0N	Moulded Ring
25	186.83353H0N	Sound Proofing, Front Motor Support
26	186.83352H0N	Sound Proofing, Rear Motor Support
27	186.50000H0N	Motor Support
28	186.50002H0N	Conveyor Plate
29	186.50005H0N	Valve Body
30	186.50001H0N	Valve Flap
31	186.70003H0N	Float Gasket
32	186.50014H0N	Float
33	186.30100H0X	Float Protection Grid
34	186.25804H0X	RD Head S/T Screw M4.2 x 30
35	186.50008H0N	Cartridge Holder Basket
36	186.50023H0N	Pre-Filter Cage
37	186.50024H0N	Pre-Filter Flange
38	186.01410H0N	Adaptor Disc Assy

NOTE: It is our policy to continually improve products and as such we reserve the right to alter data, specifications and component parts without prior notice.

IMPORTANT: No liability is accepted for incorrect use of product.

WARRANTY: Guarantee is 12 months from purchase date, proof of which will be required for any claim.

Sealey Group, Kempson Way, Suffolk Business Park, Bury St Edmunds, Suffolk. IP32 7AR



01284 757500



01284 703534



sales@sealey.co.uk



www.sealey.co.uk



Parts Information:
**Vacuum Cleaner Industrial Wet &
 Dry Twin Motor 90ltr Stainless Drum
 1200/2400W/230V with Pump
 Model No: PC90P**

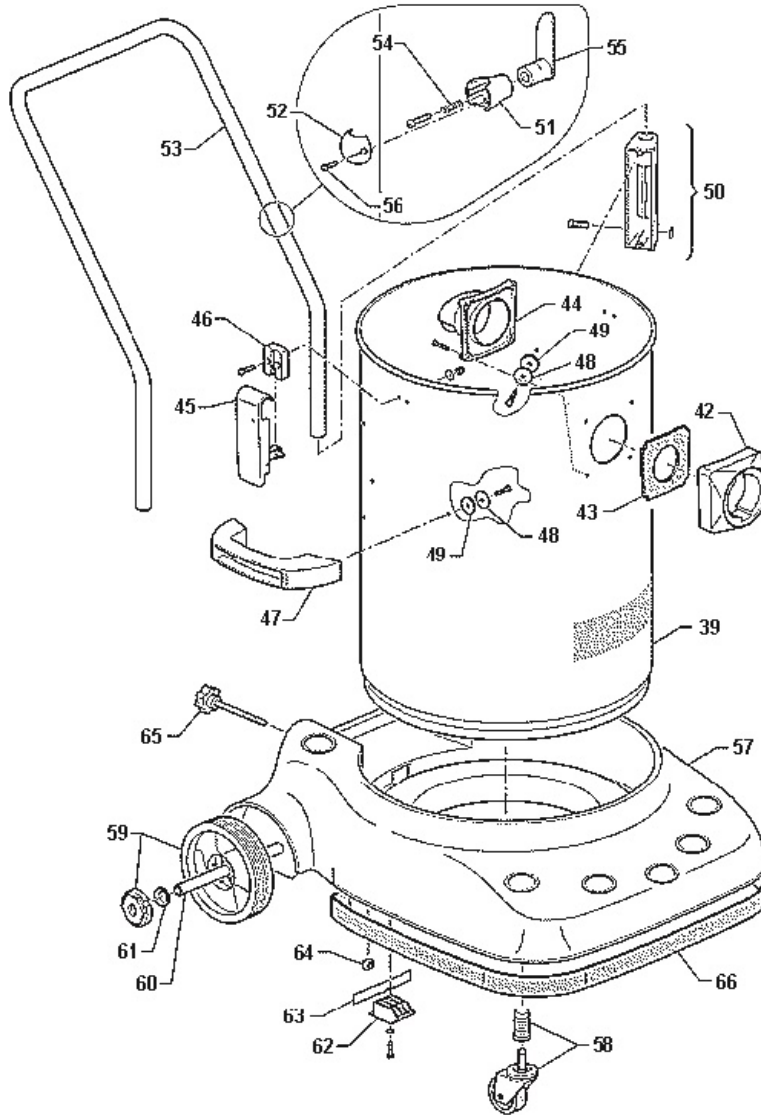

Item	Part No.	Description
39	186.10002H0X	Stainless Steel Container
42	186.50017H00	Air Inlet Connection
43	186.70006H0N	Gasket
44	186.50016H0N	Elbowed Inlet Tube
45	186.01015H00	Complete Hinge
46	186.50019H0N	Hinge Support
47	186.50025H00	Handle
48	186/25120D0X	Stainless Steel Washer
49	186.70009H0N	Gasket 26x5x2
50	186.01900H00	Handle Support Assy
51	186.50027H0N	Hub
52	186.50029H0N	Winding Bridge
53	186.40010H0N	Handle

Item	Part No.	Description
54	186.30066G0X	Spring
55	186.50028H0N	Hook
56	186.25803H0X	TC Screw 3x16mm
57	186.50018H00	Trolley
58	186.30082H0X	Wheel,Castor (63x6x23x93)
59	186/95206HOV	Wheel Kit (150x35x15)
60	186.40200H0X	Axle
61	186.30400H0X	Washer
62	186.50011H0N	Drum Fastening Bolt
63	186.30070H0X	Spring Plate
64	186.25715H0X	M8 Square Nut(Stainless Steel)
65	186.30001H0X	Handwheel
66	186.60030H0N	Shock Proof Band

NOTE: It is our policy to continually improve products and as such we reserve the right to alter data, specifications and component parts without prior notice.

IMPORTANT: No liability is accepted for incorrect use of product.

WARRANTY: Guarantee is 12 months from purchase date, proof of which will be required for any claim.

Sealey Group, Kempson Way, Suffolk Business Park, Bury St Edmunds, Suffolk. IP32 7AR



01284 757500



01284 703534



sales@sealey.co.uk



www.sealey.co.uk

Parts Information:
**Vacuum Cleaner Industrial Wet &
 Dry Twin Motor 90ltr Stainless Drum
 1200/2400W/230V with Pump
 Model No: PC90P**

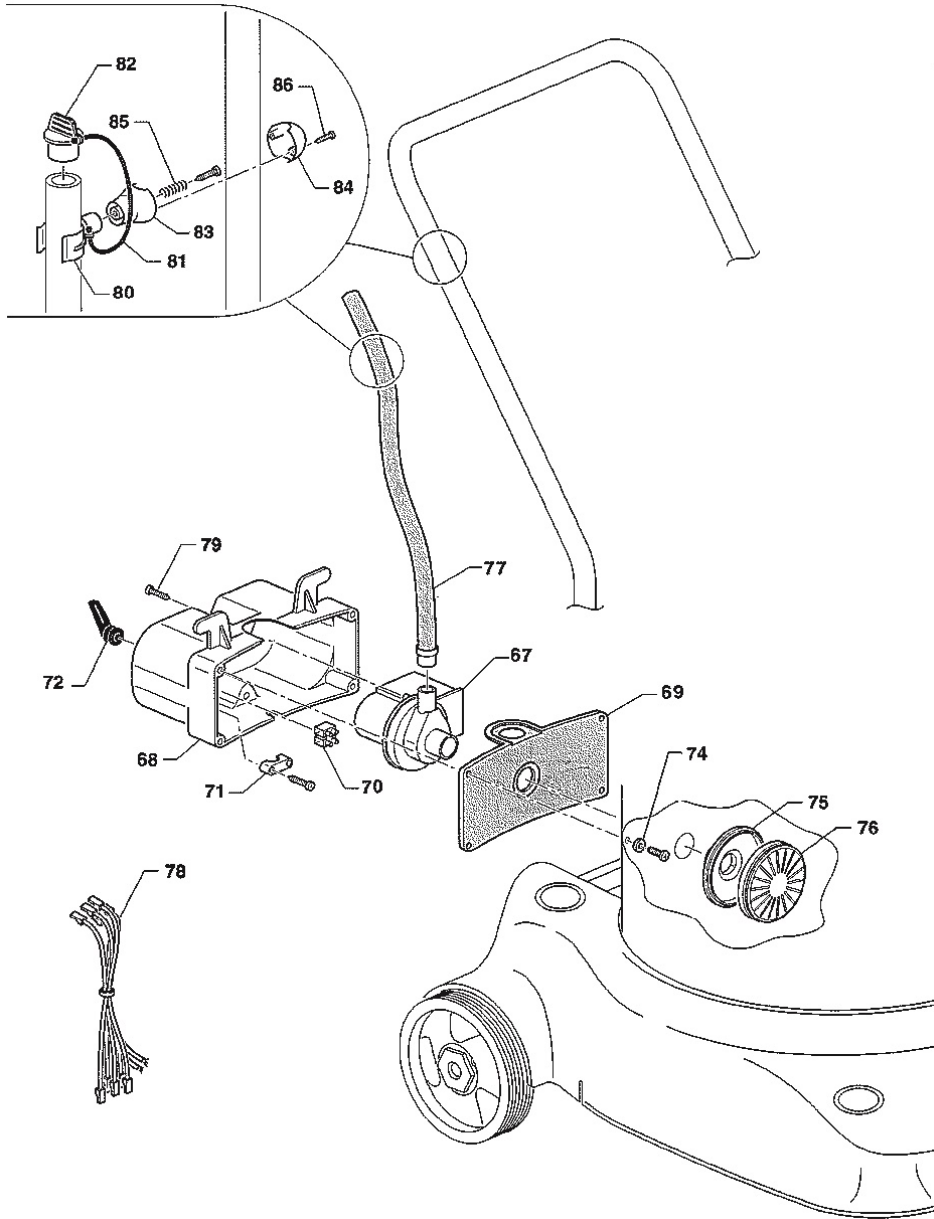

Item	Part No.	Description
67	186.80300H0U	Pump
68	186.50012H00	Pump Cover
69	186.70008H0N	Gasket
70	186/80030ZOI	Block
71	186.50078G0V	Cable Fastener
72	186.70095G0N	Cable Guide
--	186.80001H0N	Feeder (NOT SHOWN)
74	186.50030H0N	Plastic Caps
75	186.50020H0N	Pump Filter Well
76	186.50021H0N	Filtering Section

Item	Part No.	Description
77	186.60015H0N	Drain Pipe
78	186.80151H0V	Set Of Wires
79	186.25806H0X	Screw 3.5x20mm
80	186.50032H0N	Tube Blocking Staple
81	186.50033H0N	Clamp
82	186.50031H0N	Plug
83	186.50027H0N	Hub
84	186.50029H0N	Winding Bridge
85	186.30066G0X	Spring
86	186.25803H0X	TC Screw 3x16mm

NOTE: It is our policy to continually improve products and as such we reserve the right to alter data, specifications and component parts without prior notice.

IMPORTANT: No liability is accepted for incorrect use of product.

WARRANTY: Guarantee is 12 months from purchase date, proof of which will be required for any claim.



Parts Information:
**Vacuum Cleaner Industrial Wet &
 Dry Twin Motor 90ltr Stainless Drum
 1200/2400W/230V with Pump
 Model No: PC90P**

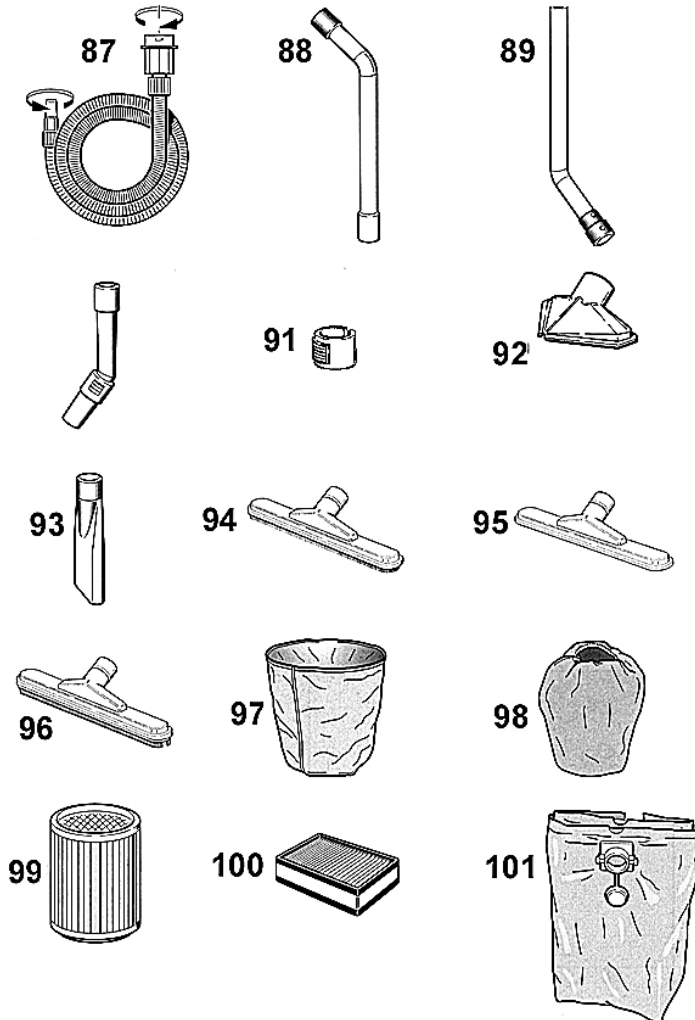

Item	Part No.	Description
87	186.01300H0N	Flexible Hose With Swivelling Connectors
88	186/40020B5N	Tube,Upper,Curved Chrome 45mm
89	186/01000B5X	Tube,Lower,Curved Chrome 45mm With Cuff
--	186.50094B0N	Grip (NOT SHOWN)
91	186/50095B0N	Ring, Outflow
92	186.50090B0N	Triangular Nozzle
93	186.50087B0N	Crevice Tool
94	186/60005B5N	Floor Nozzle With Brush 45mm

Item	Part No.	Description
95	186/60006B5N	Floor Nozzle,Carpet 45mm
96	186/01000B5N	Floor Nozzle,Liquid 45mm
97	186.83010H0I	Basket Filter
98	186.83035H0B	Sponge Filter
99	186.83140H0G	Cartridge Filter
100	186.83150H0I	Outlet Air Post Filter
101	186.83139H0B	Collection Bags Pack Of 5

NOTE: It is our policy to continually improve products and as such we reserve the right to alter data, specifications and component parts without prior notice.

IMPORTANT: No liability is accepted for incorrect use of product.

WARRANTY: Guarantee is 12 months from purchase date, proof of which will be required for any claim.

Sealey Group, Kempson Way, Suffolk Business Park, Bury St Edmunds, Suffolk. IP32 7AR



01284 757500



01284 703534



sales@sealey.co.uk



www.sealey.co.uk