

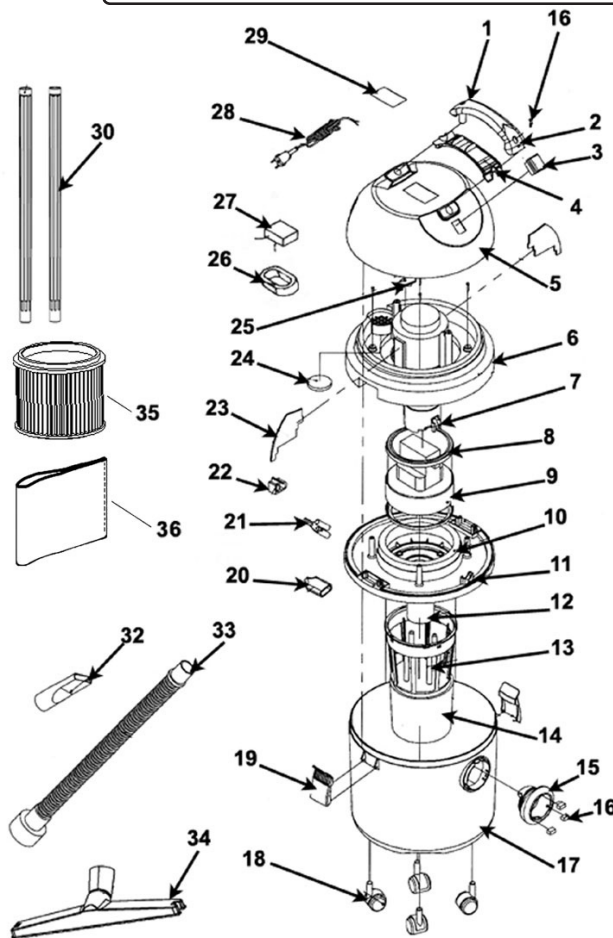

Parts Information:
Vacuum Cleaner Wet/Dry 20ltr
1250W/230V
Model No: PC200.V2



Item	Part No.	Description
1	PC200.01	SCREW
2	PC200.02	UPPER HANDLE
3	PC200.03	SWITCH
4	PC200.04	LOWER HANDLE
5	PC200.05	UPPER COVER
6	PC200.06	MIDDLE COVER
7	PC200.07	BAFFLE
8	PC200.08	SEALED RING
9	PC200.09	MOTOR
10	PC200.10	FOAM RING
11	PC200.11	LOWER COVER
12	PC200.12	WATERPROOF CUP
13	PC200.13	BASKET
14	PC200.14	FOAM FILTER (SINGLE)
15	PC200.15	HOSE BASE
16	PC200.16	PLASTIC STOPPER
17	PC200.17	TANK
18	PC200.18	WHEEL,CASTOR (D:37xW:27xH:44)
19	PC200.19	CATCH

Item	Part No.	Description
20	PC200.20	SOCKET
21	PC200.21	WIRE PLUG
22	PC200.22	WIRE SLOT
23	PC200.23	BOARD
24	PC200.24	FILTER
25	PC200.25	CLIP
26	PC200.26	CAPACITOR
27	PC200.27	CAPACITOR 15uf 250x275v 2x0.5
28	MC3CX1.0	MAINS CABLE BLK, 3 CORE, 1.0MM2
29	PC200.29	LABEL
30	PC200.30	PLASTIC TUBE
32	PC200.32	NARROW NOZZLE
33	PC200.33	HOSE
34	PC200.34	FLAT ABSORB NOZZLE
35	PC200CF	CARTRIDGE FILTER
36	PC200FF10	FOAM FILTER
--	PC200PB5	DUST COLLECTION BAG (NOT SHOWN)
--	VACHOSE5M	VACUUM HOSE 5mtr (NOT SHOWN)

NOTE: It is our policy to continually improve products and as such we reserve the right to alter data, specifications and component parts without prior notice.

IMPORTANT: No liability is accepted for incorrect use of product.

WARRANTY: Guarantee is 12 months from purchase date, proof of which will be required for any claim.

Sealey Group, Kempson Way, Suffolk Business Park, Bury St Edmunds, Suffolk. IP32 7AR



01284 757500



01284 703534



sales@sealey.co.uk



www.sealey.co.uk