

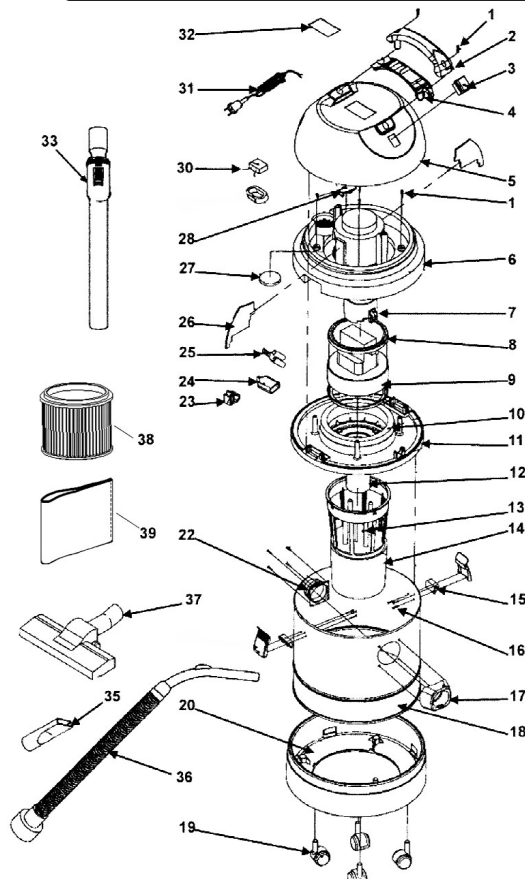

Parts Information:
**Vacuum Cleaner Industrial Wet/Dry 20ltr
 1250W/230V Stainless Bin
 Model No: PC200SD.V2**



Item	Part No.	Description
1	PC200.01	Screw
2	PC200.02	Upper Handle
3	PC200.03	Switch
4	PC200.04	Lower Handle
5	PC200.05	Upper Cover
6	PC200.06	Middle Cover
7	PC200.07	Baffle
8	PC200.08	Sealed Ring
9	PC200SD.09	Motor 1400w
10	PC200.10	Foam Ring
11	PC200.11	Lower Cover
12	PC200.12	Waterproof Cup
13	PC200.13	Basket
14	PC200FF10	Foam Filter Series Pack Of 10
15	PC200SD.V3-24	Hook Base
16	PC200SD.16	Screws
17	PC200SD.17	Hose Base
18	PC200SD.18	Tank 20ltr
19	PC200.18	Wheel,Castor (d:37xw:27xh:44)
20	PC200SD.20	Base

Item	Part No.	Description
22	PC200SD.22	Hose Base
23	PC200.22	Wire Slot
24	PC200.20	Socket
25	PC200.21	Wire Plug
26	PC200.23	Board
27	PC200.24	Filter
28	PC200.25	Clip
30	PC200.27	Capacitor 15uf 250x275v 2x0.5
31	MC3CX1.0	Mains Cable Blk, 3 core, 1.0mm2
32	PC200SD.32	Label
33	PC300SD.V3-53	Telescopic Stainless Tube
35	PC200.32	Narrow Nozzle
36	PC200SD.36	Inlet Suction Hose W/Adjustable Flow Switch
37	PC200SD.37	Combo Nozzle
38	PC200CF	Cartridge Filter
39	PC200FF10	Foam Filter Series Pack Of 10
--	PC310.06	Bin Clip (NOT SHOWN)
--	PC200.14	Foam Filter (Single) (NOT SHOWN)
--	PC200PB5	Dust Collection Bag Series Pack Of 5 (NOT SHOWN)
--	VACHOSE5M	Vacuum Hose 5mtr (NOT SHOWN)

NOTE: It is our policy to continually improve products and as such we reserve the right to alter data, specifications and component parts without prior notice.

IMPORTANT: No liability is accepted for incorrect use of product.

WARRANTY: Guarantee is 12 months from purchase date, proof of which will be required for any claim.

Sealey Group, Kempson Way, Suffolk Business Park, Bury St Edmunds, Suffolk. IP32 7AR



01284 757500



01284 703534



sales@sealey.co.uk



www.sealey.co.uk