

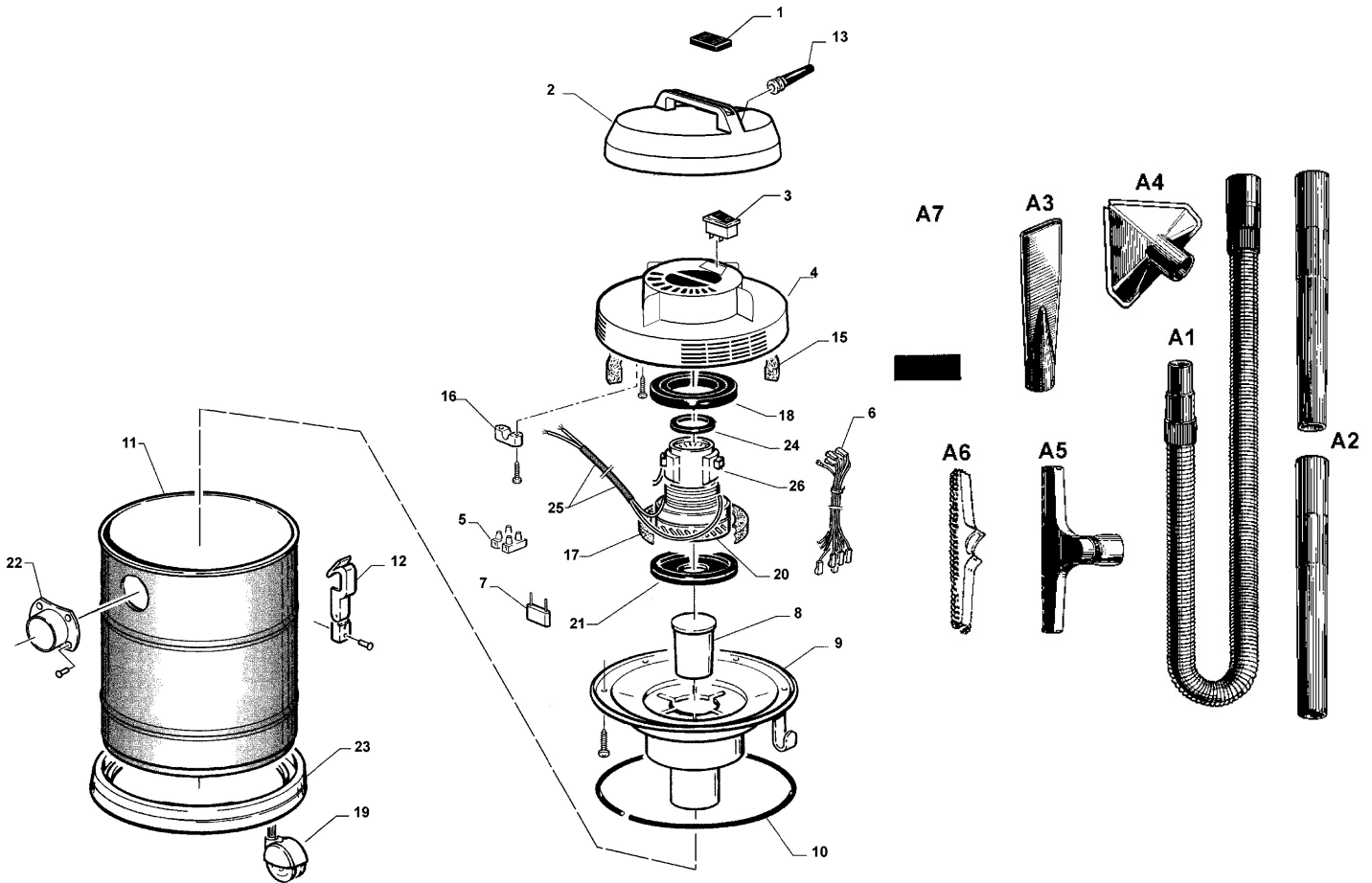

Parts Information:
Vacuum Cleaner Industrial Wet/Dry15ltr
1100W/230V
Model No: PC150



Item	Part No.	Description
1	186/70018BON	Cover,Switch
2	186.50186BOR	Cover (Red)
3	181/1682270	Switch
4	186.50200BOR	Motor Cover (Red)
5	186/80030ZOI	Block
6	186/80097BOV	Connection
7	186/80021BOX	Noise Filter
8	186/50077BOV	Float
9	186.50064BOR	Motor Support
10	186/70016BON	Lid Gasket (Dia. 5mm)
11	186.50190BON	Container
12	186/01016BOU	Bin Clip
13	186/50036ZON	Cable Sleeve(M10 x 52)
--	MC2CX1.0	Mains Cable Blk, 2 Core, 1.0mm ² (NOT SHOWN)
15	186.83102BCN	Filter Grille
16	186/50078ZOX	Cable Grip
17	186/83020B8X	Filter Ring
18	186/70055BON	Gasket,Motor Middle

Item	Part No.	Description
19	186/30085BOX	Wheel,Castor (34x8x26x46)
20	186.20058BOX	Motor (Internal 1000W A200)
21	186/70032BON	Motor Gasket,Lower
22	186/50210BOC	Hose Inlet
23	186/50123B6R	Round Trolley
24	186.70062BON	Upper Motor Absorber
25	186/60235BHN	Plastic Tube 110mm x 6mm Diameter
26	186.80051B5X	Brush Holder Insert
--	186/50183BOV	Protection Grille (NOT SHOWN)
--	186.60805B6N	2.5mm Thickness Ring (NOT SHOWN)
A1	186/01317BON	Hose Complete, 1.5m x 50mm
A2	186/50091BON	Extension, Polypropilene, D.45
A3	186/50080BON	Crevice Tool, D.45
A4	186/50089BON	Nozzle, Triangular, D.45
A5	186/60277BON	Frame, Floor, 45mm Diam.
A6	186/60280BON	Adaptor, Carpet
A7	186/83035BHB	Foam Filter
--	186.83144BOI	Paper Bags (Pack Of 5) (NOT SHOWN)
--	VAC/92/DL	Filter, Cartridge (NOT SHOWN)

NOTE: It is our policy to continually improve products and as such we reserve the right to alter data, specifications and component parts without prior notice.

IMPORTANT: No liability is accepted for incorrect use of product.

WARRANTY: Guarantee is 12 months from purchase date, proof of which will be required for any claim.

Sealey Group, Kempson Way, Suffolk Business Park, Bury St Edmunds, Suffolk. IP32 7AR



01284 757500



01284 703534



sales@sealey.co.uk



www.sealey.co.uk