

Parts Information:  
**Portable Floodlight 400W/230V Tungsten/  
 Halogen C-Class**  
**Model No: ML300C.V3**

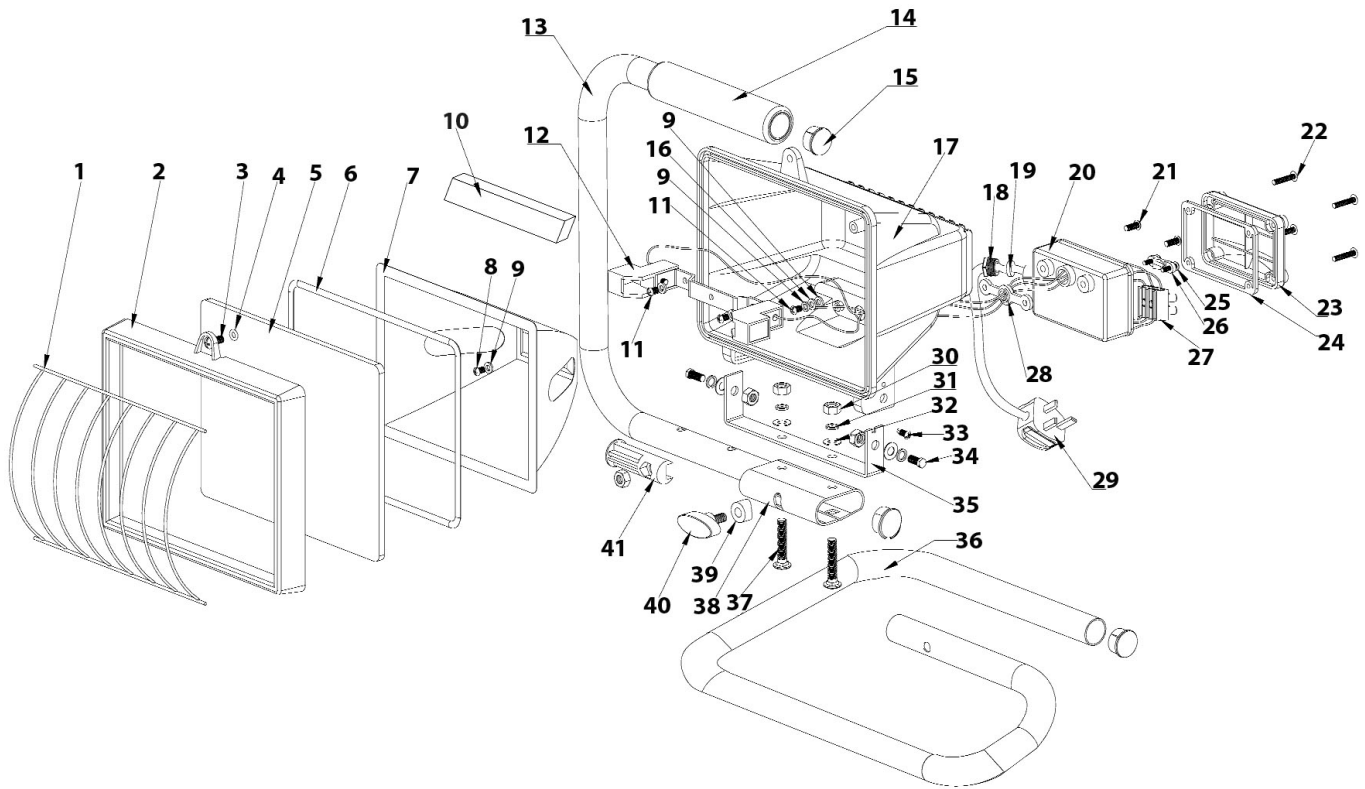

Item	Part No.	Description
1	ML500X.V3-01	GRILLE
2	ML500X.V3-02	FRAME
3	MSP46.S	MACHINE SCREW PAN HEAD PHILLIPS M4x6mm
4	ML500X.V3-04	O-RING
5	ML500X.V3-05	GLASS
6	ML500X.V3-06	SEAL GASKET
7	ML500X.V3-07	REFLECTOR
8	ML500X.V3-08	SCREW
9	ML500X.V3-09	WASHER
10	ML400B	HALOGEN BULB 400W CLASS-C
11	ML300C.V3-11	SCREW
12	ML500X.V3-12	LAMP HOLDER
13	ML300C.V3-13	HANDLE
14	ML300C.V3-14	HANDLE GRIP
15	ML300C.V3-15	END PLUG FOR HANDLE
16	ML500X.V3-13	WIRE
17	ML500X.V3-16	BODY
18	ML300C.V3-18	CABLE GRIP
19	ML300C.V3-19	RING
20	ML500X.V3-20	CONNECTION BOX (BOTTOM)
21	ML500X.V3-21	SCREW

Item	Part No.	Description
22	ML300C.V3-22	RD HEAD S/T SCREW M3X18
23	ML500X.V3-23	CONNECTION BOX COVER
24	ML500X.V3-24	CONNECTION BOX SEAL
25	ML500X.V3-25	SCREW
26	ML500X.V3-26	CABLE CLIP
27	ML500X.V3-27	TERMINAL BLOCK
28	ML300C.V3-28	WIRE GRIP
29	ML300C.V3-29	CABLE & PLUG
30	ML36.24	HEX NUT
31	ML500X.V3-30	SPRING WASHER
32	ML500X.V3-29	WASHER
33	MSP512.S	MACHINE SCREW PAN HEAD PHILLIPS M5x12mm
34	SS614.S	HEX HEAD SET SCREW M6x14mm SINGLE
35	ML300C.V3-35	BRACKET
36	ML300C.V3-36	HANDLE BASE
37	CBN632.SB	COACH BOLT M6x32mm BLACK
38	ML300C.V3-38	HANDLE SLEEVE
39	ML300C.V3-39	PLASTIC RING
40	ML300C.V3-40	KNOB SCREW
41	ML300C.V3-41	HANDLE SLEEVE STOPPER

**NOTE:** It is our policy to continually improve products and as such we reserve the right to alter data, specifications and component parts without prior notice.

**IMPORTANT:** No liability is accepted for incorrect use of product.

**WARRANTY:** Guarantee is 12 months from purchase date, proof of which will be required for any claim.