

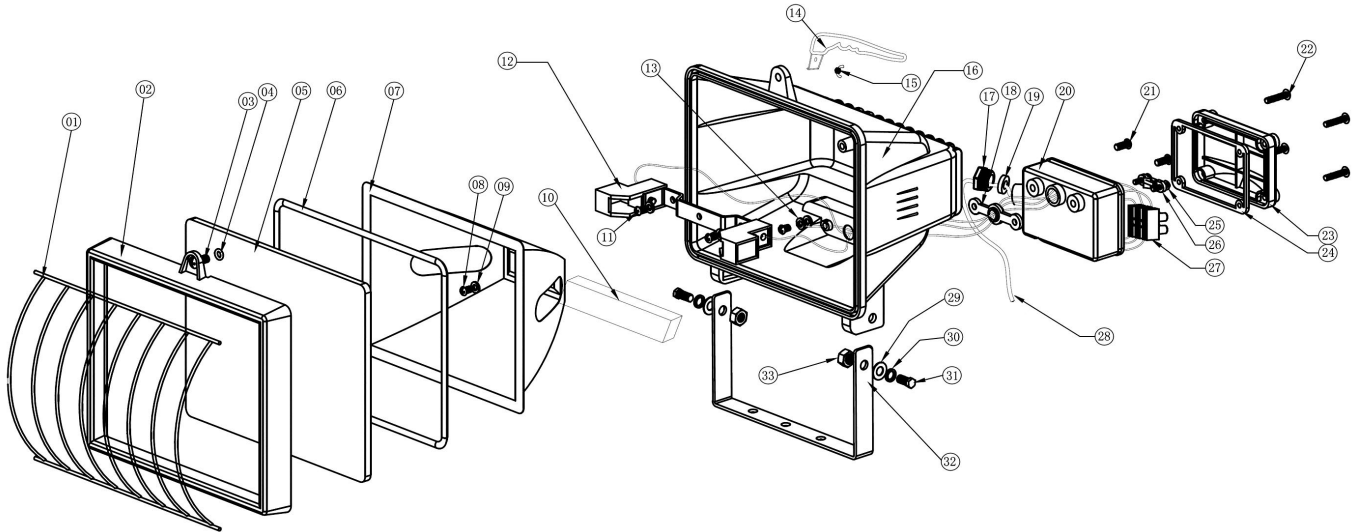

Parts Information:  
**Telescopic Floodlight 2 x 400W/110V**  
**Tungsten/Halogen C-Class**  
**Model No: ML1000D/110V.V3**



Item	Part No.	Description
1	ML500X.V3-01	GRILLE
2	ML500X.V3-02	FRAME
3	ML500X.V3-03	SCREW
4	ML500X.V3-04	O-RING
5	ML500X.V3-05	GLASS
6	ML500X.V3-06	SEAL GASKET
7	ML500X.V3-07	REFLECTOR
8	ML500X.V3-08	SCREW
9	ML500X.V3-09	WASHER
10	ML400B110V	HALOGEN BULB 400W CLASS-C 110V
11	ML500X.V3-11	SCREW
12	ML500X.V3-12	LAMP HOLDER
13	ML500X.V3-13	WIRE
14	ML500X.V3-14	HANDLE
15	ML500X.V3-15	NUT
16	ML500X.V3-16	BODY
17	ML500X.V3-17	CABLE GRIP

Item	Part No.	Description
18	ML500X.V3-18	TERMINAL WIRE CLAMP
19	ML500X.V3-19	RING
20	ML500X.V3-20	CONNECTION BOX (BOTTOM)
21	ML500X.V3-21	SCREW
22	ML500X.V3-22	SCREW
23	ML500X.V3-23	CONNECTION BOX COVER
24	ML500X.V3-24	CONNECTION BOX SEAL
25	ML500X.V3-25	SCREW
26	ML500X.V3-26	CABLE CLIP
27	ML500X.V3-27	TERMINAL BLOCK
28	MC3CX1.0	MAINS CABLE BLK, 3 CORE, 1.0MM2
29	ML500X.V3-29	WASHER
30	ML500X.V3-30	SPRING WASHER
31	ML500X.V3-31	SCREW
32	ML500X.V3-32	BRACKET
33	ML500X.V3-33	NUT
--	ML500X.V3-S	STAND ASSEMBLY (NOT SHOWN)

**NOTE:** It is our policy to continually improve products and as such we reserve the right to alter data, specifications and component parts without prior notice.

**IMPORTANT:** No liability is accepted for incorrect use of product.

**WARRANTY:** Guarantee is 12 months from purchase date, proof of which will be required for any claim.

**Sealey Group**, Kempson Way, Suffolk Business Park, Bury St Edmunds, Suffolk. IP32 7AR



01284 757500



01284 703534



sales@sealey.co.uk



www.sealey.co.uk



Parts Information:  
**Telescopic Floodlight 2 x 400W/110V**  
**Tungsten/Halogen C-Class**  
**Model No: ML1000D/110V.V3**

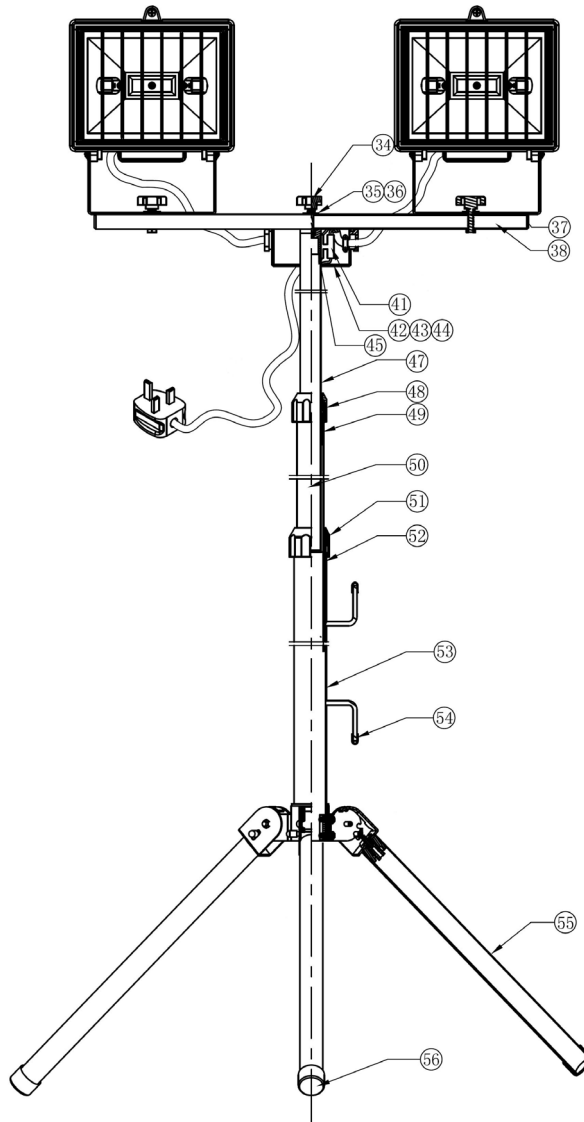

Item	Part No.	Description
34	ML1000D.V3-34	THREAD SCREW
35	RW619.S	REPAIR WASHER M6x19 (SINGLE)
36	ML1000D.V3-36	BRACKET
37	ML1000D.V3-37	STOPPER
38	ML1000D.V3-38	CROSS MEMBER
41	ML1000D.V3-41	TERMINAL BLOCK
42	ML1000D.V3-42	CONNECTION BOX (BOTTOM)
43	ML1000D.V3-43	CONNECTION BOX, COVER
44	ML1000D.V3-44	COVER SEAL
45	ML1000D.V3-45	STOPPER

Item	Part No.	Description
47	ML1000D.V3-47	SMALL TUBE
48	ML1000D.V3-48	SMALL INSERT
49	ML1000D.V3-49	SMALL CONNECTOR
50	ML1000D.V3-50	MIDDLE TUBE
51	ML1000D.V3-51	BIG INSERT
52	ML1000D.V3-52	BIG CONNECTOR
53	ML1000D.V3-53	BIG TUBE
54	ML1000D.V3-54	SEAL COVER
55	ML1000D.V3-55	STAND LEG
56	ML1000D.V3-56	STAND LEG FOOT

**NOTE:** It is our policy to continually improve products and as such we reserve the right to alter data, specifications and component parts without prior notice.

**IMPORTANT:** No liability is accepted for incorrect use of product.

**WARRANTY:** Guarantee is 12 months from purchase date, proof of which will be required for any claim.

**Sealey Group**, Kempson Way, Suffolk Business Park, Bury St Edmunds, Suffolk. IP32 7AR



01284 757500



01284 703534



sales@sealey.co.uk



www.sealey.co.uk