

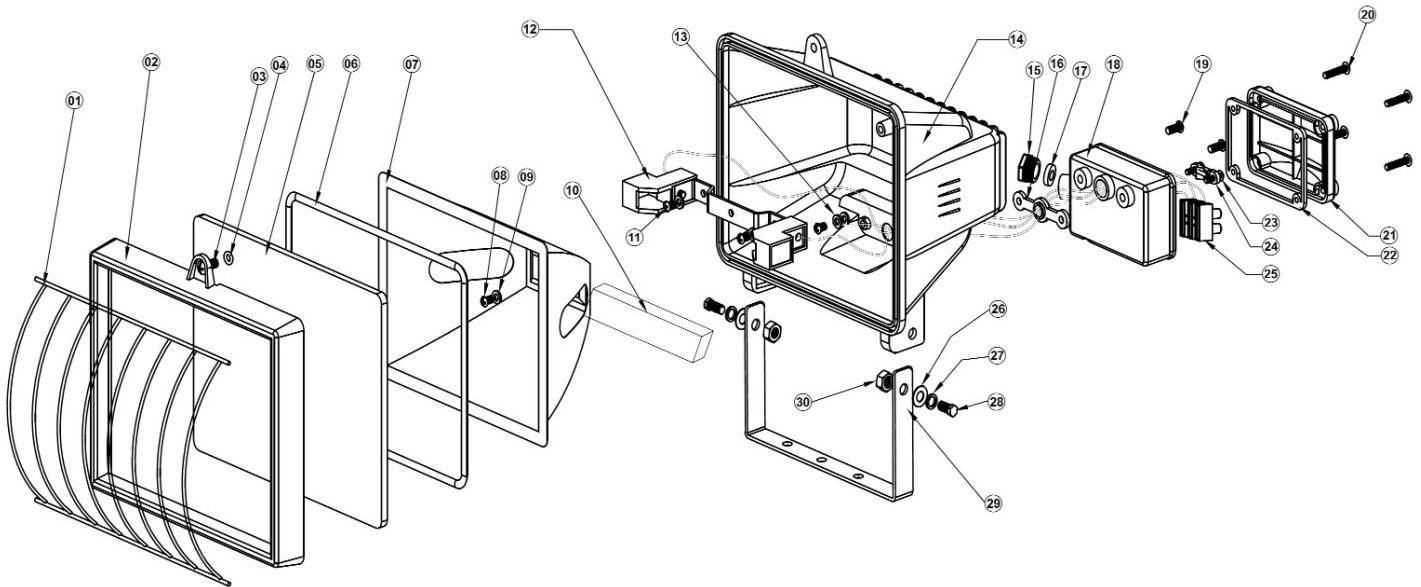

Parts Information:
Floodlight with Wall Bracket 400W/230V
Tungsten/Halogen C-Class
Model No: MD500C.V2



Item	Part No.	Description
1	ML500X.V3-01	GRILLE
2	ML500X.V3-02	FRAME
3	MD500C.V2-03	SCREW
4	ML500X.V3-04	O-RING
5	ML500X.V3-05	GLASS
6	ML500X.V3-06	SEAL GASKET
7	ML500X.V3-07	REFLECTOR
8	ML500X.V3-08	SCREW
9	ML500X.V3-09	WASHER
10	ML400B	HALOGEN BULB 400W CLASS-C
11	ML500X.V3-11	SCREW
12	ML500X.V3-12	LAMP HOLDER
13	ML500X.V3-13	WIRE
14	ML500X.V3-16	BODY
15	ML500X.V3-17	CABLE GRIP

Item	Part No.	Description
16	ML500X.V3-18	TERMINAL WIRE CLAMP
17	ML500X.V3-19	RING
18	ML500X.V3-20	CONNECTION BOX (BOTTOM)
19	ML500X.V3-21	SCREW
20	ML500X.V3-22	SCREW
21	ML500X.V3-23	CONNECTION BOX COVER
22	ML500X.V3-24	CONNECTION BOX SEAL
23	ML500X.V3-25	SCREW
24	ML500X.V3-26	CABLE CLIP
25	ML500X.V3-27	TERMINAL BLOCK
26	ML500X.V3-29	WASHER
27	ML500X.V3-30	SPRING WASHER
28	MD500C.V2-28	SCREW
29	ML500X.V3-32	BRACKET
30	ML500X.V3-33	NUT

NOTE: It is our policy to continually improve products and as such we reserve the right to alter data, specifications and component parts without prior notice.

IMPORTANT: No liability is accepted for incorrect use of product.

WARRANTY: Guarantee is 12 months from purchase date, proof of which will be required for any claim.

Sealey Group, Kempson Way, Suffolk Business Park, Bury St Edmunds, Suffolk. IP32 7AR



01284 757500



01284 703534



sales@sealey.co.uk



www.sealey.co.uk