

Item	Part No.	Description

NOTE: It is our policy to continually improve products and as such we reserve the right to alter data, specifications and component parts without prior notice.

IMPORTANT: No liability is accepted for incorrect use of product.

WARRANTY: Guarantee is 12 months from purchase date, proof of which will be required for any claim.



Parts Information:
**Motorcycle Lift 450kg Capacity Hydraulic
Model No: MC455.V2**

Item	Part No.	Description
1	MC455.01	RUBBER GRIP
2	MC455.02	HANDLE
3	MC455.03	BRAKE ROPE
4	MC455.04	BOLT
5	MC455.05	SAFETY PIN
6	MC455.06	HEAD JOINT
7	MC455.07	LOCK NUT
8	MC455.08	WASHER
9	MC455.09	LINK ROD
10	MC455.10	STEPPED BOLT
11	MC455.11	LIFTING ARM
12	MC455.12	BUSH
13	MC455.13	BRAKE
14	MC455.14	HYDRAULIC UNIT
15	MC455.15	BOLT
16	MSP510.S	MACHINE SCREW PAN HEAD PHILLIPS M5x10mm
17	MC455.17	FOOT PEDAL
18	MC455.18	MAIN FRAME
19	MC455.19	HAND WHEEL
20	SN12.SD	STEEL NUT M12 DOMED (SINGLE)
21	MC455.21	SWIVEL CASTOR 39X35X7
22	MC455.22	BOLT
23	MC455.23	WASHER

Item	Part No.	Description
24	MC455.24	LOCK NUT
25	MC455.25	BOLT
26	MC455.26	WHEEL 79X28X10
27	MC455.27	WASHER
28	NLN10.S	NYLOC NUT M10 ZINC (SINGLE)
29	MC455.29	LIFTING ARM
30	HHB1690.S	HEX HEAD BOLT M16x90mm SINGLE
31	MC455.V2-31	U-CLAMP
32	MC455.V2-32	NUT
33	SWM8.SB	SPRING WASHER M8 BLACK(SINGLE)
34	MC455.V2-34	BOLT
35	MC455.V2-35	FIXED VICE
36	MC455.V2-36	MOVABLE VICE
37	MC455.V2-37	SCREW
38	MC455.V2-38	FIXING SCREW NUT
39	MC455.V2-39	THREADED ROD
40	MC455.V2-40	PLATFORM
41	MC455.V2-41	BOLT
42	MC455.V2-42	EXTENDABLE SUPPORT
43	MC455.V2-43	SPRING WASHER
44	MC455.V2-44	NUT
45	MC455.V2-45	LEADING PLATE
46	MC455.V2-46	BAFFLE PLATE

NOTE: It is our policy to continually improve products and as such we reserve the right to alter data, specifications and component parts without prior notice.

IMPORTANT: No liability is accepted for incorrect use of product.

WARRANTY: Guarantee is 12 months from purchase date, proof of which will be required for any claim.

Sealey Group, Kempson Way, Suffolk Business Park, Bury St Edmunds, Suffolk. IP32 7AR



01284 757500



01284 703534



sales@sealey.co.uk



www.sealey.co.uk

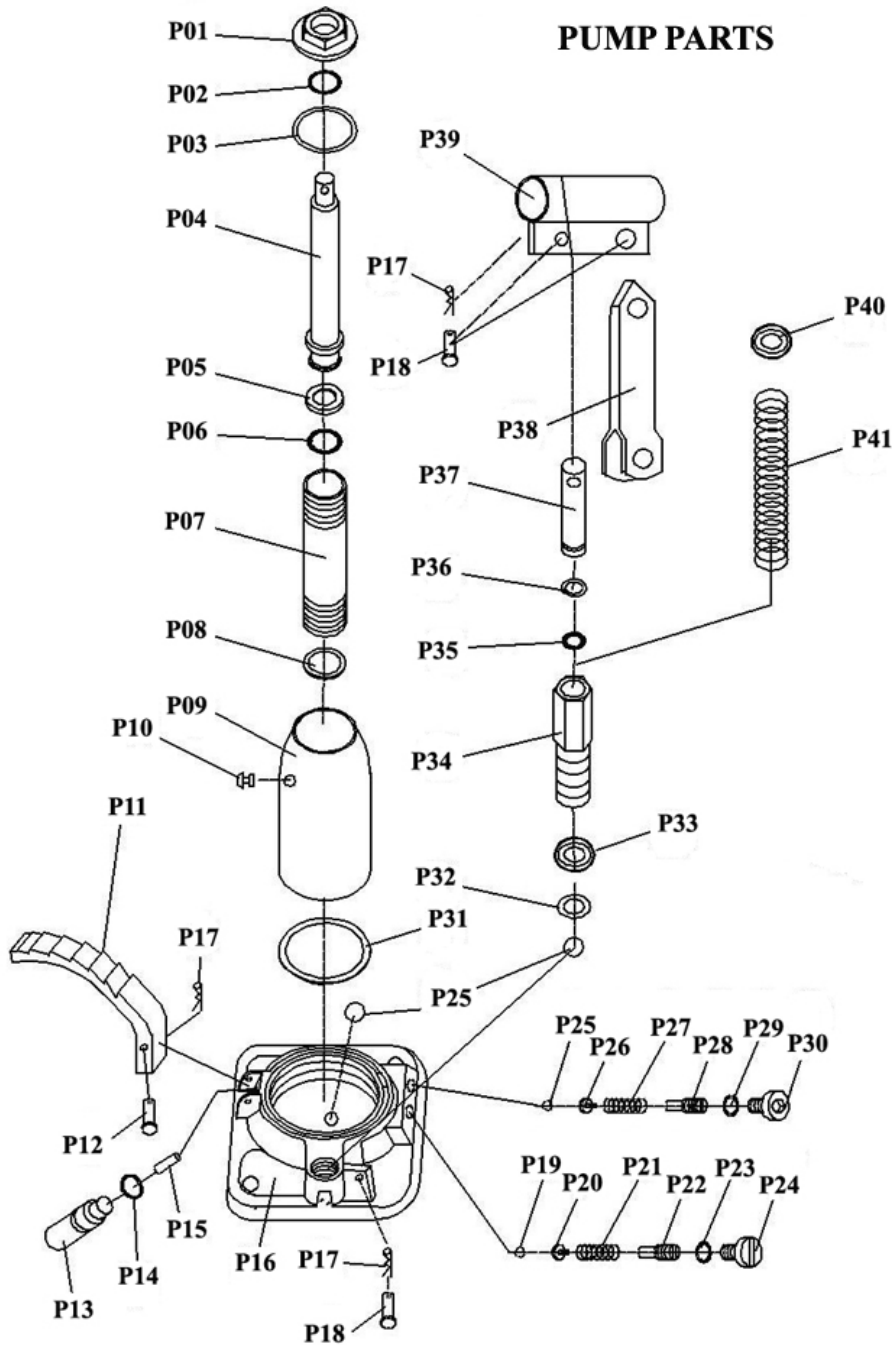

NOTE: It is our policy to continually improve products and as such we reserve the right to alter data, specifications and component parts without prior notice.

IMPORTANT: No liability is accepted for incorrect use of product.

WARRANTY: Guarantee is 12 months from purchase date, proof of which will be required for any claim.



Parts Information:
**Motorcycle Lift 450kg Capacity Hydraulic
Model No: MC455.V2**

Item	Part No.	Description
P1	MC455.P01	RAM CAP
P2	MC455.P02	RAM O-RING
P3	MC455.P03	TOP SEAL GASKET
P4	MC455.P04	RAM ASSEMBLY
P5	MC455.P05	RAM GASKET
P6	MC455.P06	O-RING
P7	MC455.P07	CYLINDER
P8	MC455.P08	LOWER SEALING GASKET
P9	MC455.P09	OIL RESERVOIR
P10	MC455.P10	OIL FILLER PLUG
P11	MC455.P11	PEDAL RELEASE VALVE
P12	MC455.P12	PIN
P13	MC455.P13	RELEASE VALVE ROD
P14	MC455.P14	O-RING
P15	MC455.P15	RELEASE VALVE PIN
P16	MC455.P16	BASE
P17	MC455.P17	COTTER PIN
P18	MC455.P18	PIN
P19	MC455.P19	STEEL BALL
P20	MC455.P20	SPRING PLUNGER
P21	MC455.P21	SPRING

Item	Part No.	Description
P22	MC455.P22	SCREW
P23	MC455.P23	O-RING
P24	MC455.P24	SCREW
P25	SB-6.0	STEEL BALL 6.0mm
P26	MC455.P26	SPRING PLUNGER
P27	MC455.P27	SPRING
P28	MC455.P28	SCREW
P29	MC455.P29	COPPER WASHER
P30	MC455.P30	SCREW
P31	MC455.P31	LOWER SEALING GASKET
P32	MC455.P32	COPPER WASHER
P33	MC455.P33	LOWER SPRING RETAINER
P34	MC455.P34	PUMP CYLINDER
P35	MC455.P35	O-RING
P36	MC455.P36	SEAL
P37	MC455.P37	PISTON ROD
P38	MC455.P38	LINK
P39	MC455.P39	HANDLE SOCKET
P40	MC455.P40	SPRING RETAINER
P41	MC455.P41	SPRING

NOTE: It is our policy to continually improve products and as such we reserve the right to alter data, specifications and component parts without prior notice.

IMPORTANT: No liability is accepted for incorrect use of product.

WARRANTY: Guarantee is 12 months from purchase date, proof of which will be required for any claim.

Sealey Group, Kempson Way, Suffolk Business Park, Bury St Edmunds, Suffolk. IP32 7AR



01284 757500



01284 703534



sales@sealey.co.uk



www.sealey.co.uk