

Model MA90SC

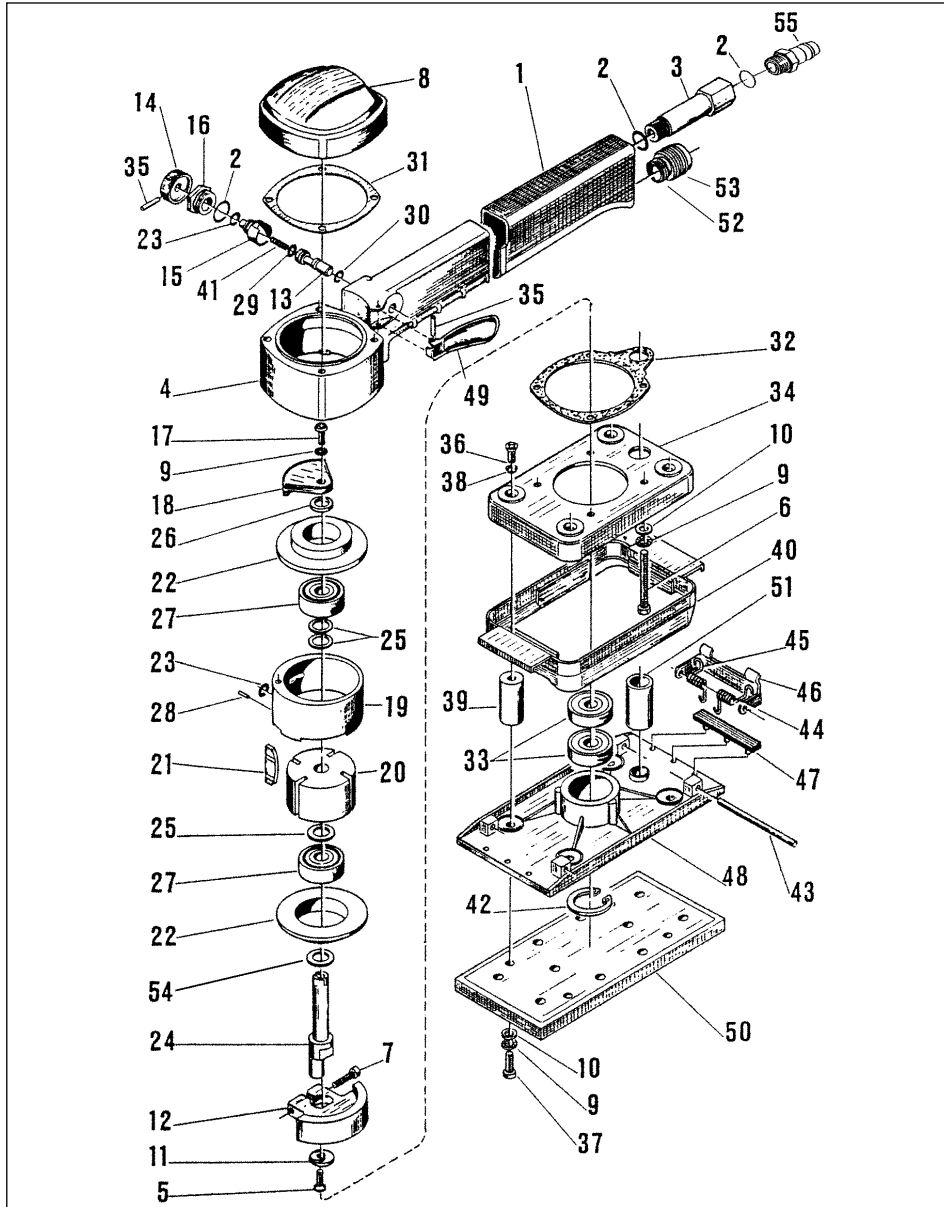

Item	Part No.	Description	Item	Part No.	Description
1	122/10.01.05	Rubber Grip	35	122/23.01.20	Roll Pin 2 x 20
2	122/17.01.50	O-ring	36	122/11.03.06	Screw, 4 x 8
3	122/99.50.20	Air Inlet	37	122/11.07.02	Screw, 4 x 12
4	122/10.02.11	Motor Body	38	122/13.01.21	Spring Washer
5	122/11.01.01	Screw, 4 x 12	39	122/24.03.09	Rubber Silentbloc
6	122/11.04.20	Screw, 4 x 50	40	122/24.03.11	Rubber Protection
7	122/11.06.01	Screw, 4 x 25	41	122/25.01.05	Valve Spring
8	122/12.01.13	Cover	42	122/19.01.01	Circlip
9	122/13.01.01	Washer	43	122/23.20.01	Lock Pin
10	122/13.02.01	Flat Washer	44	122/25.02.10	Lock Spring - Right
11	122/13.10.02	Counterbalance Washer	45	122/25.02.11	Lock Spring - Left
12	122/14.04.11	Lower Counterbalance	46	122/26.02.14	Paper Lock
13	122/15.01.20	Valve Pin	47	122/26.02.16	Lock Rubber
14	122/15.01.24	Air Regulator Handle	48	122/26.03.12	Backing Plate
15	122/15.01.25	Air Regulator Valve	49	122/27.01.21	Lever
16	122/15.01.26	Air Regulator Cap	50	122/30.01.50	Rubber Plate
17	122/11.03.11	Screw, 4 x 16	51	122/66.50.10	Rubber Dust Connection
18	122/14.01.11	Upper Counterbalance	52	122/68.02.13	Connector
19	122/16.02.11	Cylinder	53	122/68.02.12	Extraction Connector
20	122/16.02.12	Rotor	54	122/19.49.50	Dust Stop
21	122/16.02.13	Vane	55	122/97.10.31	Quick Connect, 1/4"
22	122/16.02.14	Flange	-	122/16.02.10	Motor Complete (9, 17 to 28, 54)
23	122/17.01.20	O-ring	-	122/26.03.11	Backing Plate with Locks (42 to 48)
24	122/18.01.09	Motor Shaft	-	122/10.01.01	Rubber Handle Complete (1 to 3)
25	122/19.50.01	Motor Spacers	-	122/58.01.10	Paper Perforator
26	122/19.50.50	Distance Piece	-	122/60.01.11	Dust Bag
27	B/6200ZZ	Bearing	-	122/66.02.11	Dust Hose, D29 x 1.5m
28	122/23.01.01	Pin, 3 x 6			
29	122/17.01.15	O-ring			
30	122/17.01.30	O-ring			
31	122/17.30.10	Cover Gasket			
32	122/17.30.20	Motor Gasket			
33	B/6200-2RS	Bearing			
34	122/22.02.15	Bottom Cover			

Issue No: 3
Issue Date: 200104

SEALEY POWER TOOLS Sole UK Distributor, Sealey Group, Bury St. Edmunds, Suffolk.

01284 757500 01284 703534 E-mail: sales@sealey.co.uk Web: www.sealey.co.uk