

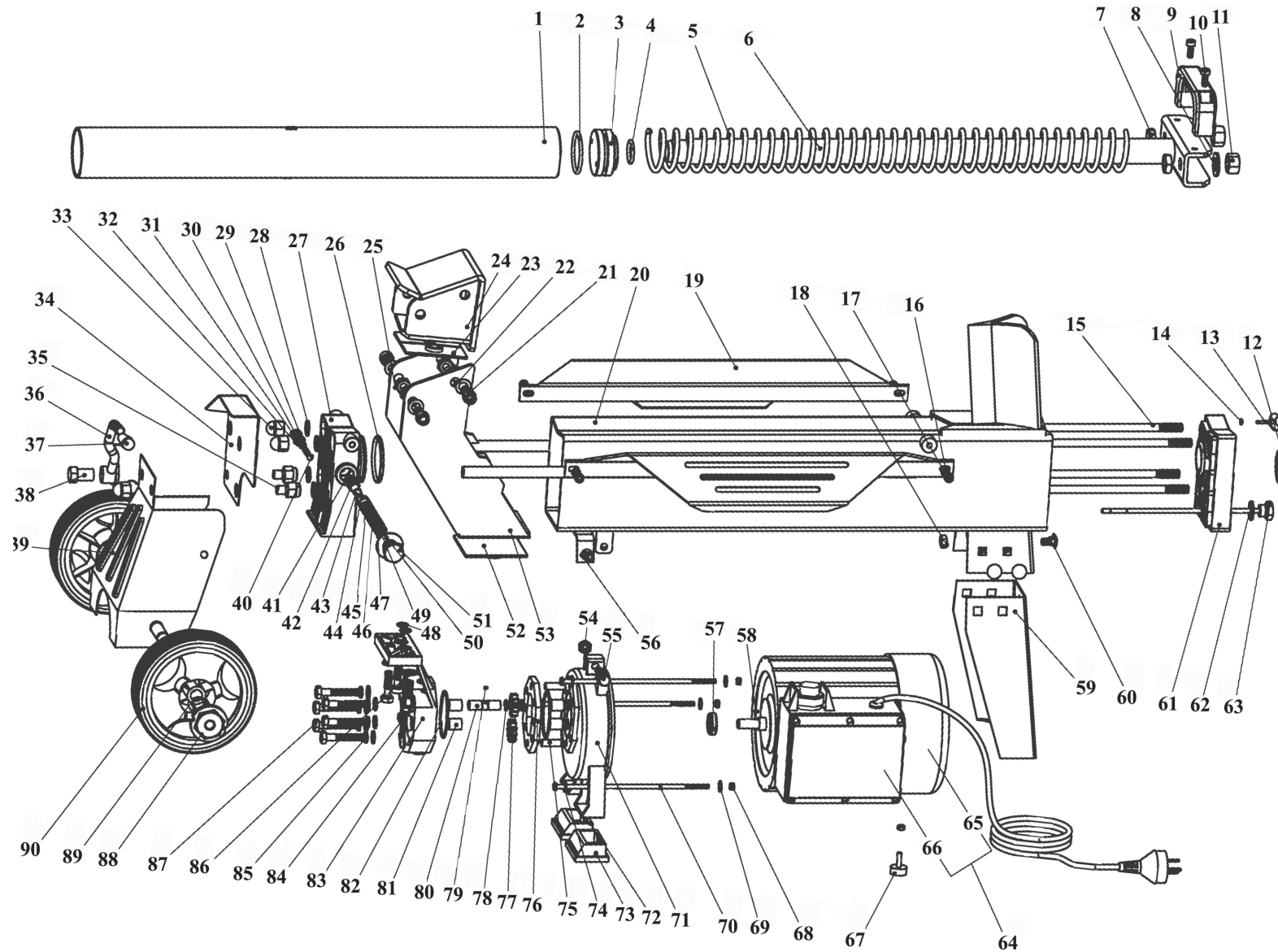

Parts Information:
Horizontal Log Splitter 5tonne 520mm Capacity
Model No: LS520H



Sealey Group, Kempson Way, Suffolk Business Park, Bury St Edmunds, Suffolk. IP32 7AR



01284 757500



01284 703534



sales@sealey.co.uk



www.sealey.co.uk



Parts Information:
**Horizontal Log Splitter 5tonne 520mm
Capacity
Model No: LS520H**

Item	Part No.	Description
1	LS520H.01	CYLINDER
2	LS520H.02	PISTON O-RING
3	LS520H.03	PISTON
4	LS520H.04	O-RING
5	LS520H.05	SPRING
6	LS520H.06	PISTON ROD
7	LS520H.07	HALF NUT M14
8	FWM14.S	FLAT WASHER M14 SINGLE
9	LS520H.09	MOVING HANDLE
10	SCB816.SB	SOCKET HEAD CAP SCREW M8x16 BLACK
11	NLN14.S	NYLOC NUT M14 ZINC DIN 985 (SINGLE)
12	LS520H.12	PLASTIC SEAL
13	LS520H.13	WING SCREW
14	LS520H.14	O-RING
15	LS520H.15	LONG STUD
16	LS520H.16	HEX BOLT (M6x12)
17	SWM6.SB	SPRING WASHER M6 BLACK(SINGLE)
18	SN8.S	STEEL NUT M8 ZINC DIN934 (SINGLE)
19	LS520H.19	SUPPORT PLATE
20	LS520H.20	FRAME
21	LS520H.21	SKT. HD BOLT M10X25
22	FWM10.S	FLAT WASHER M10 SINGLE
23	LS520H.23	UPPER PLASTIC INSERT
24	LS520H.24	LOG PUSHER
25	NLN10.S	NYLOC NUT M10 ZINC (SINGLE)
26	LS520H.26	O-RING
27	LS520H.27	CYLINDER COVER (LEFT)
28	LS520H.28	COPPER GASKET
29	LS520H.29	SAFETY VALVE SPRING
30	LS520H.30	SCREW
31	LS520H.31	SAFETY VALVE BOLT
32	LS520H.32	O-RING

Item	Part No.	Description
33	SN10.SD	STEEL NUT M10 DOMED (SINGLE)
34	LS520H.34	LEVER GUARD
35	LS520H.35	LONG NUT
36	LS520H.36	LEVER
37	LS520H.37	LEVER HEAD
38	LS520H.38	LEVER NUT
39	LS520H.39	WHEEL FRAME PLATE
40	SB-6.0	STEEL BALL 6.0mm
41	LS520H.41	CIRCLIP
42	LS520H.42	VALVE SPRING
43	LS520H.43	VALVE ROD ASS'Y
44	LS520H.44	O-RING
45	LS520H.45	VALVE SLEEVE
46	LS520H.46	O-RING
47	LS520H.47	SLIDING SLEEVE SPRING
48	LS520H.48	O-RING
49	LS520H.49	SLIDING SLEEVE
50	LS520H.50	SEALING RING
51	LS520H.51	VALVE PLUG
52	LS520H.52	LOWER PLASTIC INSERT
53	LS520H.53	LOWER PLATE
54	NLN8.S	NYLOC NUT M8 ZINC DIN 985 (SINGLE)
55	SCB835.SB	SOCKET HEAD CAP SCREW M8x35 BLACK
56	FWM5.S	FLAT WASHER M5 SINGLE
57	LS520H.57	MOTOR SHAFT SEAL
58	SB-2.5	STEEL BALL 2.5mm
59	LS520H.59	CARRIAGE BOLT
60	LS520H.60	SUPPORT LEG
61	LS520H.61	CYLINDER COVER (RIGHT)
62	LS520H.62	GASKET
63	LS520H.63	DIPSTICK
64	LS520H.64	MOTOR (c/w SWITCH)

NOTE: It is our policy to continually improve products and as such we reserve the right to alter data, specifications and component parts without prior notice.

IMPORTANT: No liability is accepted for incorrect use of product.

WARRANTY: Guarantee is 12 months from purchase date, proof of which will be required for any claim.

Sealey Group, Kempson Way, Suffolk Business Park, Bury St Edmunds, Suffolk. IP32 7AR



01284 757500



01284 703534



sales@sealey.co.uk



www.sealey.co.uk