

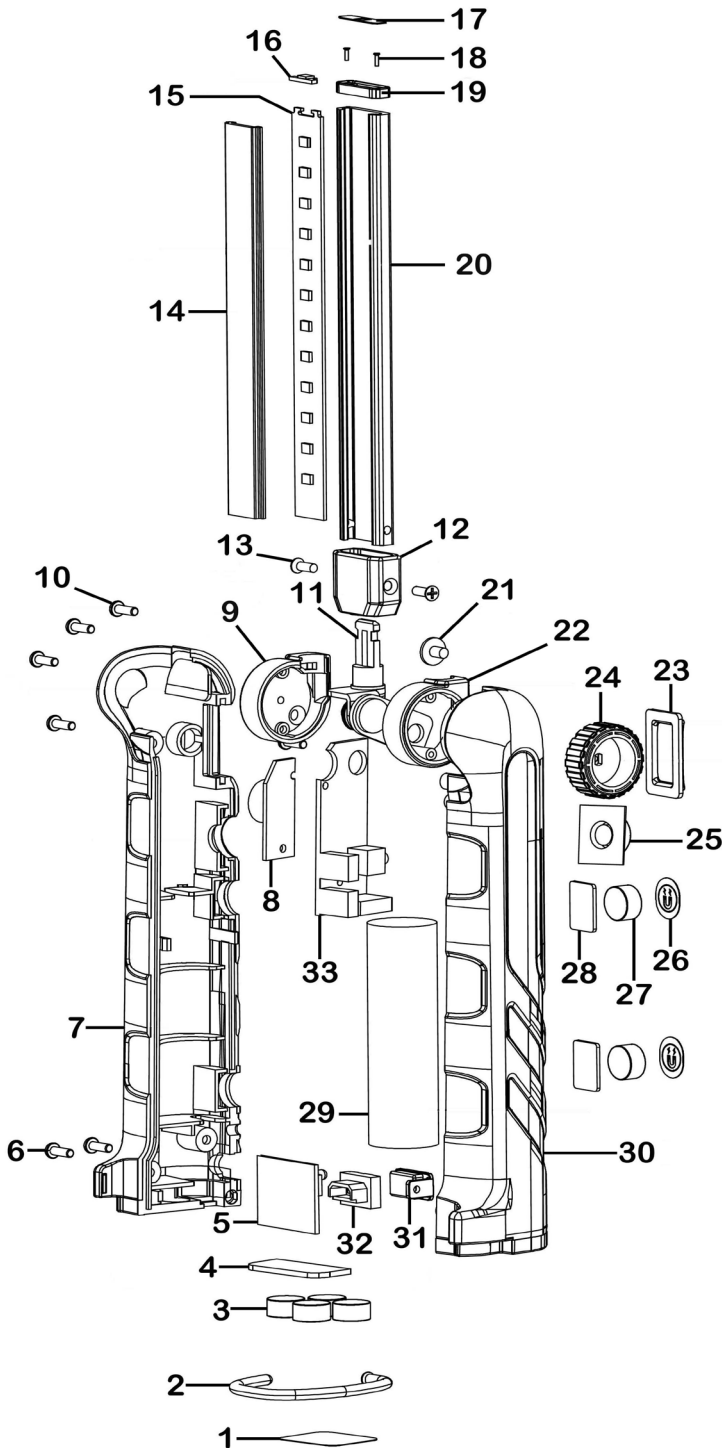

Parts Information:
**Rechargeable Slim Folding Inspection
 Light 5W & 1W SMD LED**
Model No: LED1801.V2



Item	Part No.	Description	Qty
1	LED1801.01	Rubber Pad	1
2	LED1801.02	Hook	1
3	LED1801.03	Magnet	4
4	LED1801.04	Bottom Plate	1
5	LED1801-V2-05	PCB, Charging Board, 27 X 27mm, c/w LED X1 (Charging Port C-Type)	1
6	LED1801.06	Casing Screw 2.5x10	5
7	LED1801.07	Front Cover	1
8	LED1801.08	PCB, VR Board, 30 X 12mm	1
9	LED1801.09	Swinging Strut (A)	1
10	LED1801.10	Casing Screw 2x6	4
11	LED1801.11	Metal Support Shaft	1
12	LED1801.12	Lamp Holder Bracket	1
13	LED1801.13	Lamp Holder Bracket Screw 2.5x7	2
14	LED1801.14	Front Lens	1
15	LED1801.15	Main LED Panel	1
16	LED1801.16	Head LED Plate	1
17	LED1801.17	Head LED Trim	1
18	LED1801.18	Screw 1.5x4	2
19	LED1801.19	Torch Holder	1
20	LED1801.20	Cooling Plate	1
21	MSP36.S	Machine Screw Pan Head Phillips M3 X 6mm	1
22	LED1801.22	Swinging Strut (B)	1
23	LED1801.23	Switch Bracket	1
24	LED1801.24	Master Switch	1
25	LED1801.25	Switch Button	1
26	LED1801.26	Protection Pad	2
27	LED1801.27	Magnet 10x6	2
28	LED1801.28	Backing Plate (metal)	2
29	LED1801.29	Battery, Li-Ion, 3.7V 9.62wAH 2600mAH (L: 66 W: 20)	1
30	LED1801.30	Rear Cover	1
31	LED1801.31	USB Cover	1
32	LED1801-V2-32	USB Support (Charging Port C-Type)	1
33	LED1801.33	Main Control PCB	1

NOTE: It is our policy to continually improve products and as such we reserve the right to alter data, specifications and component parts without prior notice. There may be alternative versions of this product, please contact us should you require this information.

IMPORTANT: No liability is accepted for incorrect use of product. Spare parts must be fitted by a competent person

WARRANTY: Guarantee is 12 months from purchase date, proof of which will be required for any claim.

Sealey Group, Kempson Way, Suffolk Business Park, Bury St Edmunds, Suffolk. IP32 7AR



01284 757500



sales@sealey.co.uk



www.sealey.co.uk