

Item	Part No.	Description
1	LED130.V3-01	FRONT FRAME
2	LED130.V3-02	SCREW M4x10
3	LED130110T.03	SCREW M5x25
4	LED130.V3-04	O-RING
5	LED130T.05	GLASS (177x143mm)
6	LED130.V3-06	GLASS CLIP
7	LED130.V3-07	GASKET
8	LED130.V3-08	SCREW M3x8
9	LED130.V3-09	SCREW M3x8
10	LED130.V3-10	REFLECTOR
11	LED130.V3-11	LED POWER ASSEMBLY (18x0.5W)
12	LED130.V3-12	LED MOUNTING BRACKET
13	LED130TV2-13	SCREW
14	LED130.V3-14	SCREW M4x6
15	LED130.V3-15	EARTH WIRE 0.75mm (120mm long)
16	LED130TV2-1	6 TOOTH WASHER M6
17	LED130.V3-17	SCREW M6
18	LED130.V3-18	BRACKET

Item	Part No.	Description
19	LED130.V3-20	WASHER M6
20	LED130110P.2	1 SPRING WASHER
21	LED130110P.2	4 SCREW M6x14
22	LED130110T.2	2 SMALL HANDLE
23	LED130110T.23	SCREW M5x25
24	LED130110P.35	LAMP BODY
25	LED130TV2-25	CABLE WITH BS 3-PIN PLUG
26	LED130.V3-26	TERMINAL BOX
27	LED130.V3-24	CABLE SLEEVE
28	LED130.V3-25	GROMMET
29	LED130.V3-26	TERMINAL BOX
30	LED130.V3-27	SCREW M4x10
31	LED130.V3-28	SCREW 3.5x12
32	LED130.V3-29	CABLE CLAMP
33	LED130.V3-30	TERMINAL BLOCK
34	LED130.V3-31	TERMINAL BOX SEAL
35	LED130.V3-32	TERMINAL BOX COVER
36	LED130.V3-33	SCREW 3.5x18

**NOTE:** It is our policy to continually improve products and as such we reserve the right to alter data, specifications and component parts without prior notice.

**IMPORTANT:** No liability is accepted for incorrect use of product.

**WARRANTY:** Guarantee is 12 months from purchase date, proof of which will be required for any claim.

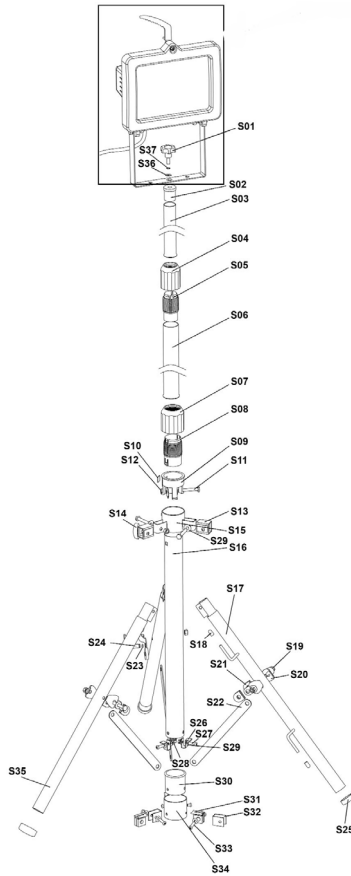

Item	Part No.	Description	Item	Part No.	Description
S01	LED130110TS01	SCREW	S20	LED130110TS20	FIXED BRACKET
S02	LED130110TS02	PLUG	S21	LED130110TS21	FIXED COVER
S03	LED130110TS03	SMALL TUBE	S22	LED130110TS22	METAL LEG BRACKET
S04	LED130110TS04	SMALL COVER	S23	LED130110TS23	WASHER
S05	LED130110TS05	SMALL JOINT	S24	LED130110TS24	BRACKET
S06	LED130110TS06	MIDDLE TUBE	S25	LED130110TS25	FOOT
S07	LED130110TS07	LARGE COVER	S26	LED130110TS26	CONNECTING STRIP
S08	LED130110TS08	LARGE JOINT	S27	LED130.V3-03	SCREW M5x18
S09	LED130110TS09	FIXING RING	S28	LED130110TS28	SCREW
S10	LED130110TS10	SPACER	S29	LED130.V3-20	WASHER M6
S11	LED130110TS11	SCREW	S30	LED130110TS30	RING
S12	LED130110TS12	SCREW	S31	LED130110TS31	PLASTIC COVER
S13	LED130110TS13	PLASTIC COVER	S32	LED130110TS32	CONNECTING STRIP
S14	LED130110P.29	KNOB	S33	LED130.V3-03	SCREW M5x18
S15	LED130110TS15	LEG BRACKET	S34	LED130110TS34	BOTTOM TUBE
S16	LED130110TS16	LARGE TUBE	S35	LED130110TS35	LEG
S17	LED130110TS17	LEG WITH CABLE HOLDER	S36	LED130.V3-20	WASHER M6
S18	LED130110TS18	BRACKET COVER	S37	LED130110P.21	SPRING WASHER
S19	LED130110TS19	SCREW			

**NOTE:** It is our policy to continually improve products and as such we reserve the right to alter data, specifications and component parts without prior notice.

**IMPORTANT:** No liability is accepted for incorrect use of product.

**WARRANTY:** Guarantee is 12 months from purchase date, proof of which will be required for any claim.