

Parts Information:
Infrared Quartz Indoor/Outdoor Heater
1500W/230V
Model No: IWMH1555

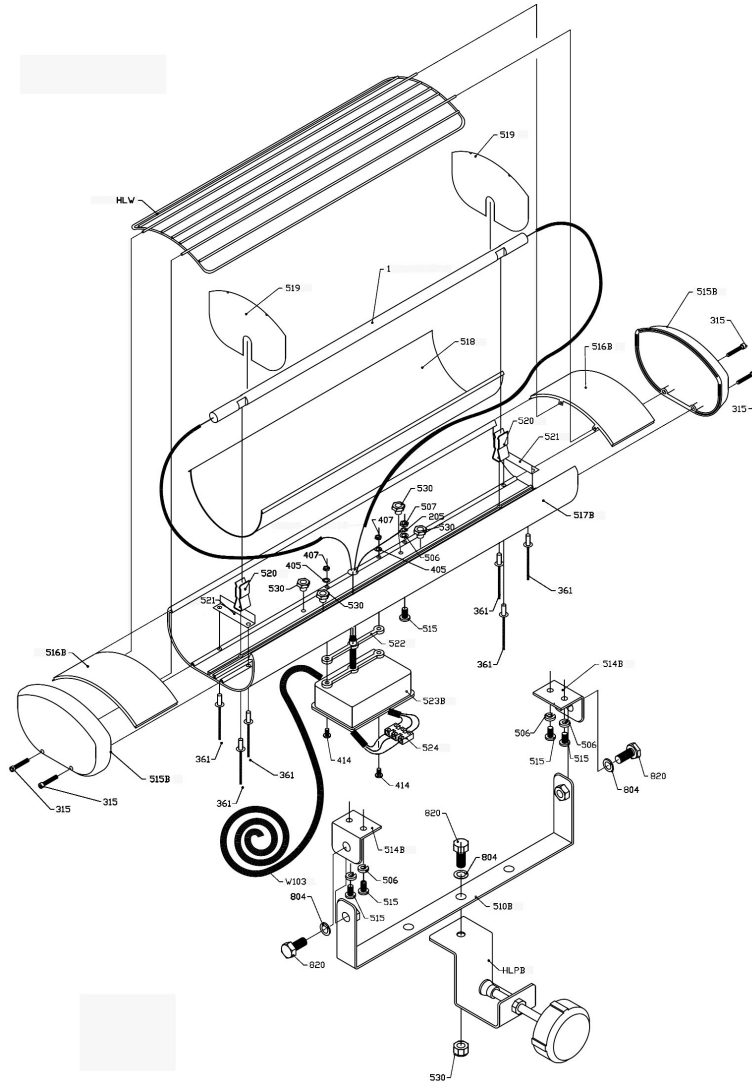

Item	Part No.	Description
1	INF64241525	HEATING ELEMENT 240V 1500W
205	IWMH1555.205	SPRING WASHER
315	IWMH1555.315	SCREW
361	IWMH1555.361	RIVET
405	IWMH1555.405	WASHER
407	IWMH1555.407	NUT
414	IWMH1555.414	SCREW
506	IWMH1555.506	WASHER
507	IWMH1555.507	NUT
510B	IWMH1555.510B	WALL BRACKET
514B	IWMH1555.514B	WALL BRACKET SUPPORT
515	IWMH1555.515	SCREW
515B	IWMH1555.515B	SIDE COVER
516B	IWMH1555.516B	TOP SIDE COVER

Item	Part No.	Description
517B	IWMH1555.517B	MAIN FRAME
518	IWMH1555.518	MAIN REFLECTOR
519	IWMH1555.519	END REFLECTOR
520	IWMH1555.520	LAMP HOLDER
521	IWMH1555.521	LAMP HOLDER BRACKET
522	IWMH1555.522	SWITCH BOX GASKET
523B	IWMH1555.523B	TERMINAL BOX
524	IWMH1555.524	TERMINAL
530	IWMH1555.530	NUT
804	IWMH1555.804	WASHER
820	IWMH1555.820	BOLT
HLPB	IWMH1555.HLPB	MOUNTING BRACKET
HLW	IWMH1555.HLW	GUARD
W103	IWMH1555.W103	MAIN CABLE ASSEMBLY

NOTE: It is our policy to continually improve products and as such we reserve the right to alter data, specifications and component parts without prior notice.

IMPORTANT: No liability is accepted for incorrect use of product.

WARRANTY: Guarantee is 12 months from purchase date, proof of which will be required for any claim.