

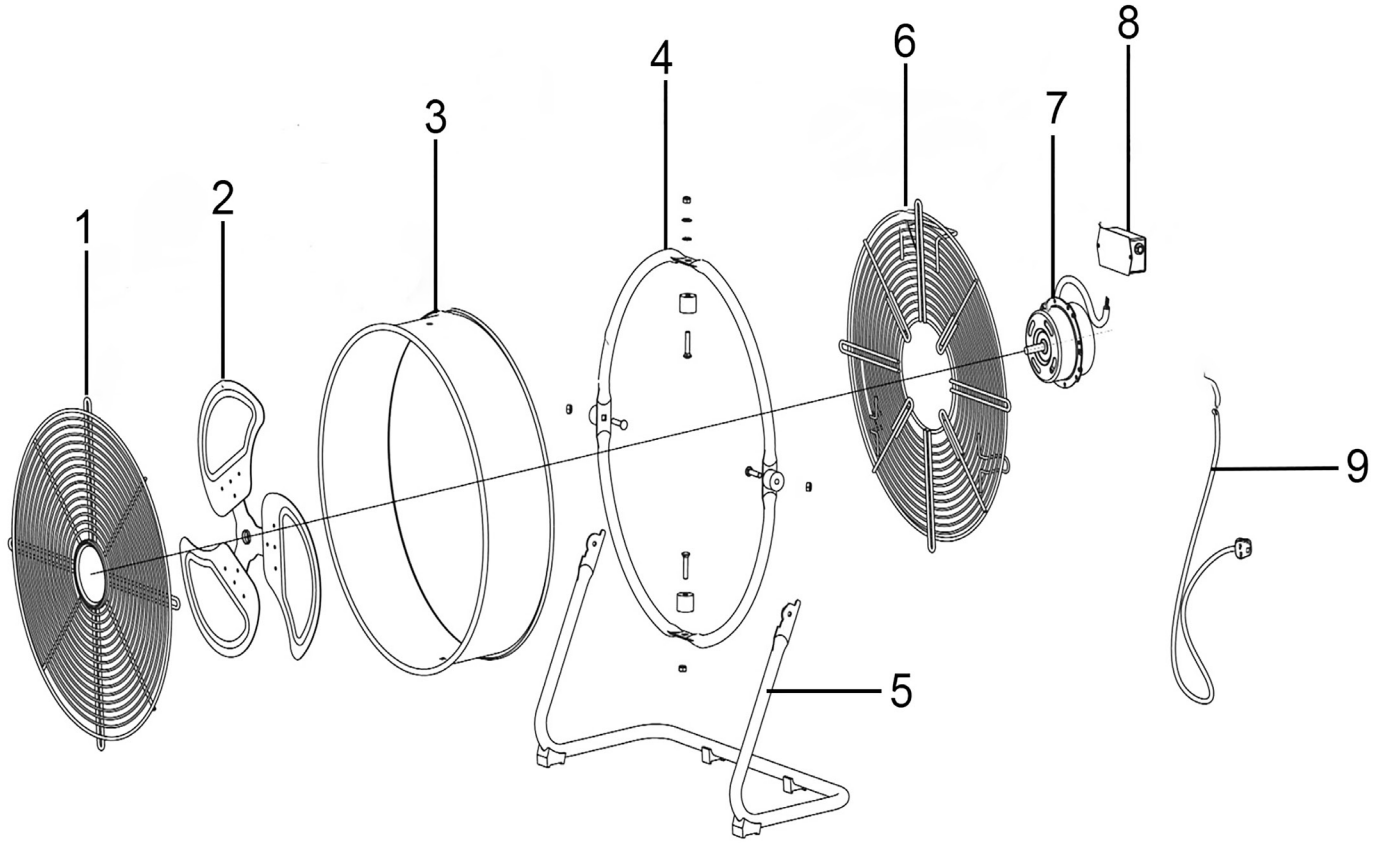

Parts Information:  
**Industrial High Velocity Orbital Drum Fan**  
**20" 230V**  
**Model No: HVF20S**



Item	Part No.	Description
1	HVF20S.01	Front Guard
2	HVF20S.02	Fan 20"
3	HVF20S.03	Drum
4	HVF20S.04	Support Ring
5	HVF20S.05	Base
6	HVF20S.06	Rear Guard
7	HVF20S.07	Motor (External 220-240v 50hz)

Item	Part No.	Description
8	HVF20S.08	Control Box
9	MC3CX0.75	Mains Cable, 3 core, 0.75 mm2 (per metre)
--	HVF20S.10	Power Selector Switch, 2.5A/250V (Not Shown)
--	HVF20S.10A	Knob, Switch, OD: 27mm, 6mm (Not Shown)
--	HVF20S.11	Capacitor, 3uf 450V (Not Shown)
--	HVF20S.12	Control Box Cover Plate (Not Shown)
--	HVF20S.FK	Fixing kit, Wall Mounting (Not Shown)

**NOTE:** It is our policy to continually improve products and as such we reserve the right to alter data, specifications and component parts without prior notice. There may be alternative versions of this product, please contact us should you require this information.

**IMPORTANT:** No liability is accepted for incorrect use of product. Spare parts must be fitted by a competent person

**WARRANTY:** Guarantee is 12 months from purchase date, proof of which will be required for any claim.

Sealey Group, Kempson Way, Suffolk Business Park, Bury St Edmunds, Suffolk. IP32 7AR



01284 757500



sales@sealey.co.uk



www.sealey.co.uk