

Platform Assembly

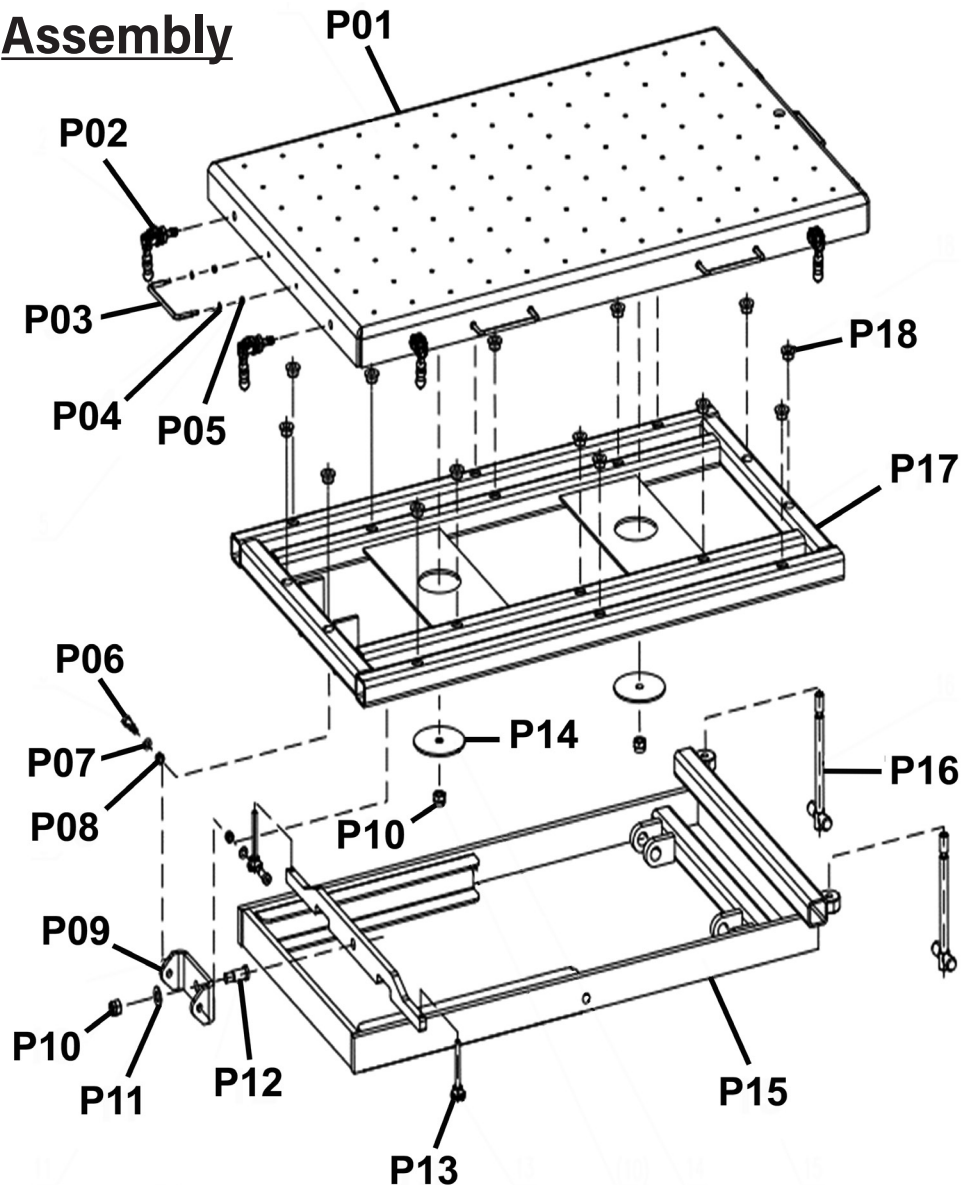

Item	Part No.	Description	Qty
P01	EVBT1200-P01	Platform	1
P02	EVBT1200-P02	Adjustment Handle	8
P03	EVBT1200-P03	Side Handle	6
P04	FWM6.S	Flat Washer M6 Zinc	12
P05	SN6.S	Steel Nut M6 Zinc	12
P06	EVBT1200-P06	Pin Screw (A)	2
P07	FWM10.S	Flat Washer M10 Zinc	2
P08	NLN10.S	Nyloc Nut M10 Zinc	2
P09	EVBT1200-P09	Bracket (U-Shape)	1
P10	NLN16.S	Nyloc Nut M16 Zinc	3
P11	FWM10.S	Flat Washer M10 Zinc	1

Item	Part No.	Description	Qty
P12	EVBT1200-P12	Pin Screw (B)	1
P13	EVBT1200-P13	Angle Locking Screw	2
P14	EVBT1200-P14	Limit Plate	2
P15	EVBT1200-P15	Chassis	1
P16	EVBT1200-P16	Angle Adjustment Screw	2
P17	EVBT1200-P17	Platform Stand	1
P18	EVBT1200-P18	Plain Bearing	16
--	EVBT1000-21	Adjustable Saddle (Not Shown)	6
--	FWM12.S	Flat Washer M12 Zinc (Not Shown)	6
--	SS1230.S	Hex Head Set Screw M12 X 30 Zinc (Not Shown)	6

NOTE: It is our policy to continually improve products and as such we reserve the right to alter data, specifications and component parts without prior notice. There may be alternative versions of this product, please contact us should you require this information.

IMPORTANT: No liability is accepted for incorrect use of product. Spare parts must be fitted by a competent person

WARRANTY: Guarantee is 12 months from purchase date, proof of which will be required for any claim.

Frame Assembly

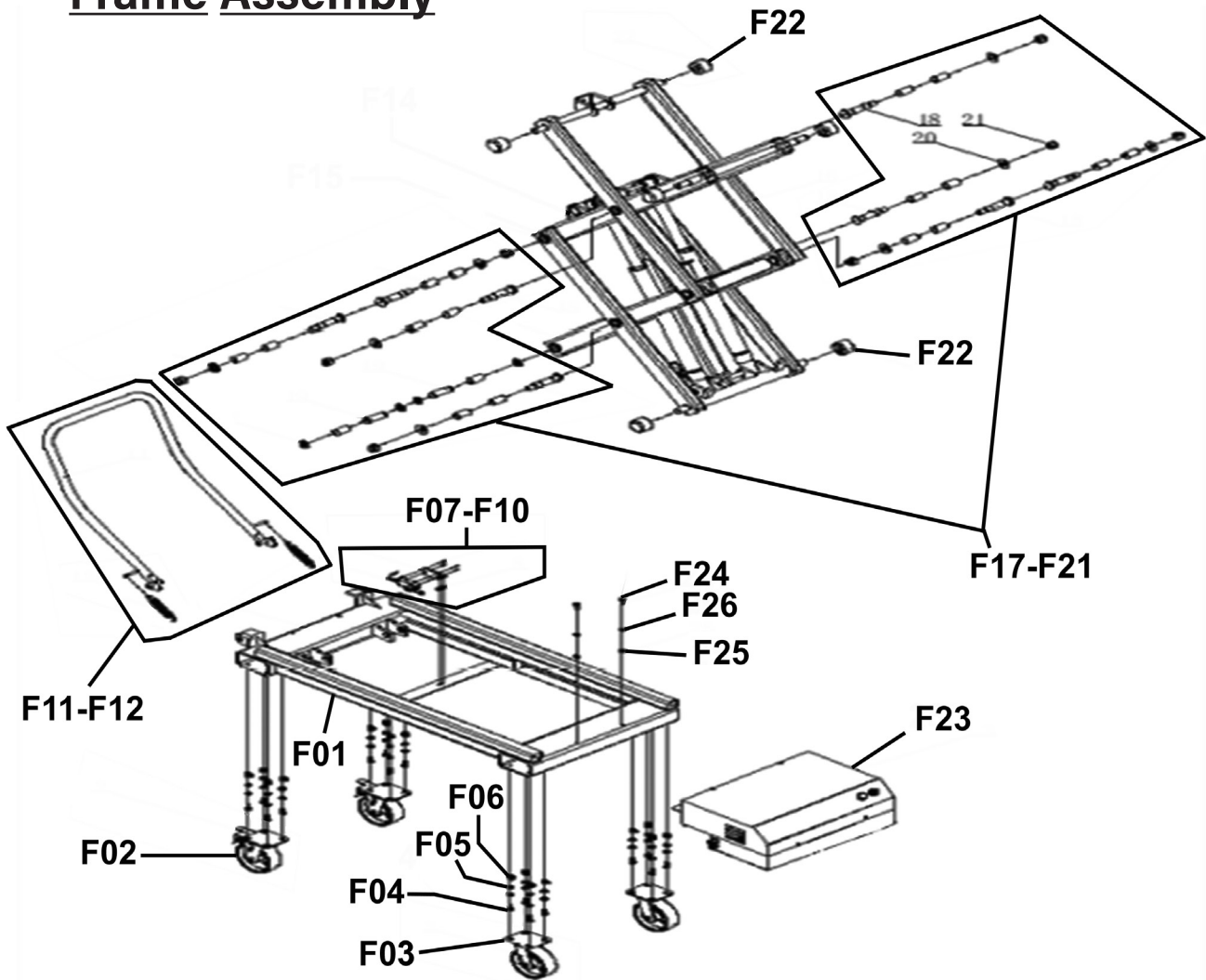

Item	Part No.	Description	Qty
F01	EVBT1200-F01	Base	1
F02	EVBT1200-F02	Wheel,Swivel Castor,4 Bolt (w/ brake)	2
F03	EVBT1200-F03	Wheel,Swivel Castor,4 Bolt	2
F04	SS1025.S	Hex Head Set Screw M10 X 25 Zinc	16
F05	FWM10.S	Flat Washer M10 Zinc	32
F06	SN10.S	Steel Nut M10 Zinc	16
F07-F10	EVBT1200-F07-F10	Limit Switch Assembly	1

Item	Part No.	Description	Qty
F11-F12	EVBT1200-F11-F12	Handle Kit	1
F17-F21	EVBT1200-F17-F21	Lifting Arm (Scissor) Shaft Kit	1
F22	EVBT1200-F22	Roller Wheel	6
F23	EVBT1200-F23	Pump	1
F24	SS1020.S	Hex Head Set Screw M10 X 20 Zinc	2
F25	FWM10.S	Flat Washer M10 Zinc	2
F26	SWM10.S	Spring Washer M10 Zinc	2

NOTE: It is our policy to continually improve products and as such we reserve the right to alter data, specifications and component parts without prior notice. There may be alternative versions of this product, please contact us should you require this information.

IMPORTANT: No liability is accepted for incorrect use of product. Spare parts must be fitted by a competent person

WARRANTY: Guarantee is 12 months from purchase date, proof of which will be required for any claim.

Parts Information:
**High Lift EV Battery Lift/Hydraulic Platform
 Truck 1200kg Capacity
 Model No: EVBT1200**

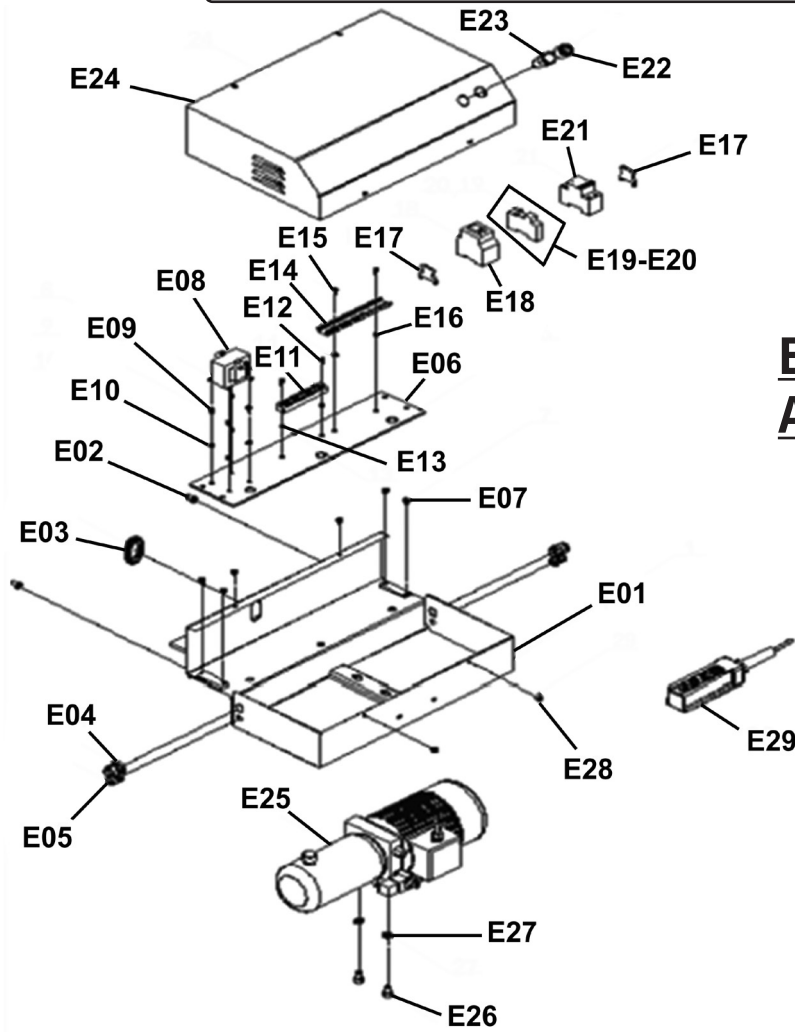

Electrical Box Assembly

Item	Part No.	Description	Qty
E01	EVBT1200-E01	Pump Case	1
E02	SS816.S	Hex Head Set Screw M8 X 16 Zinc	2
E03	EVBT1200-E03	Oil Hose Cover	1
E04	EVBT1200-E04	Wire Grip (A)	2
E05	EVBT1200-E05	Wire Grip (B)	2
E06	EVBT1200-E06	Installation Board	1
E07	MSP68.S	Machine Screw Pan Head Phillips M6 X 8mm	4
E08	EVBT1200-E08	Transformer	1
E09	MSP58.S	Machine Screw Pan Head Phillips M5 X 8mm	4
E10	SN5.S	Steel Nut M5 Zinc	4
E11	EVBT1200-E11	Strand Oscillator	1
E12	MSP410.S	Machine Screw Pan Head Phillips M4 X 10mm	2
E13	SN4.S	Steel Nut M4 Zinc	2
E14	EVBT1200-E14	Rail 140mm	1

Item	Part No.	Description	Qty
E15	SS410.S	Hex Head Set Screw M4 X 10 Zinc	2
E16	SN4.S	Steel Nut M4 Zinc	2
E17	EVBT1200-E17	Terminal (Yellow/Green)	2
E18	EVBT1200-E18	AC Contactor	1
E19-E20	EVBT1200-E19-E20	Fuse Component	1
E21	EVBT1200-E21	Breaker	1
E22	EVBT1200-E22	Breaker AC24V	1
E23	EVBT1200-E23	Indicator Light (AC22V)	1
E24	EVBT1200-E24	Pump Cover	1
E25	EVBT1200-E25	Pump 0.75kW	1
E26	SS1016.S	Hex Head Set Screw M10 X 16 Zinc	2
E27	FWM10.S	Flat Washer M10 Zinc	2
E28	MSP68.S	Machine Screw Pan Head Phillips M6 X 8mm	4
E29	EVBT1200-E29	Emergency Stop Switch	1

NOTE: It is our policy to continually improve products and as such we reserve the right to alter data, specifications and component parts without prior notice. There may be alternative versions of this product, please contact us should you require this information.

IMPORTANT: No liability is accepted for incorrect use of product. Spare parts must be fitted by a competent person

WARRANTY: Guarantee is 12 months from purchase date, proof of which will be required for any claim.

Cylinder Assembly

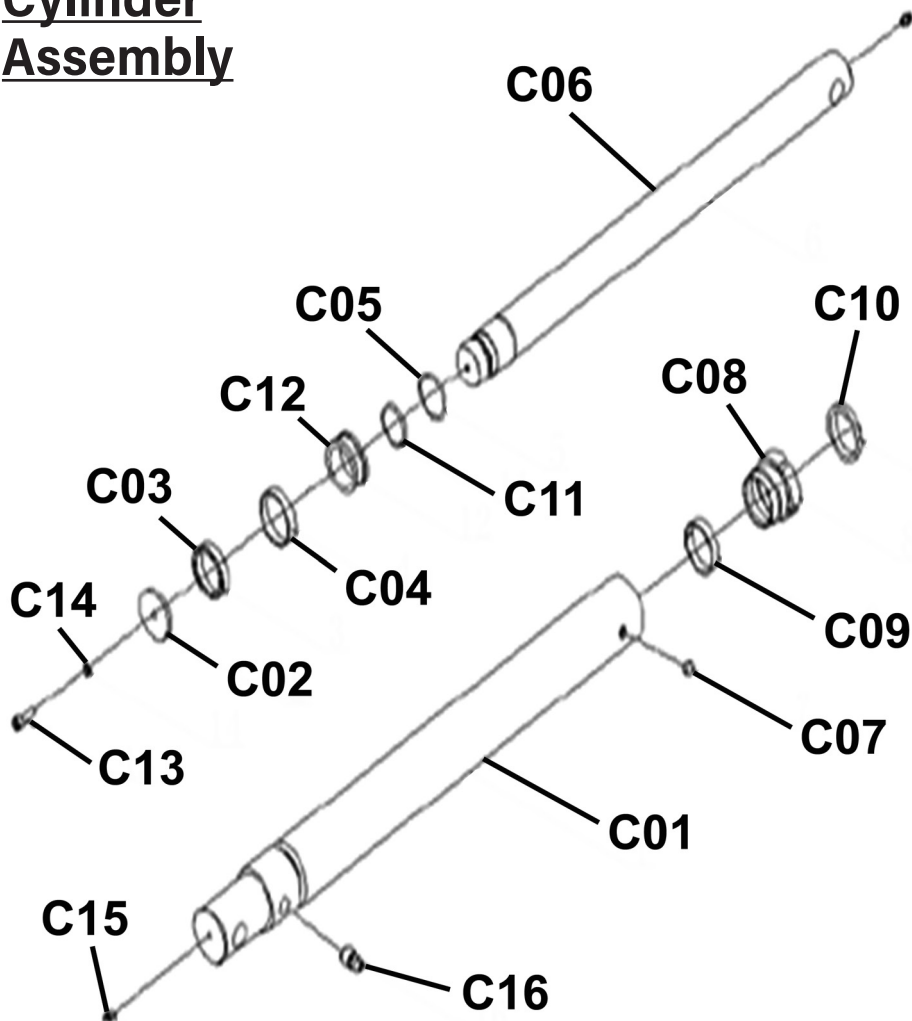

Item	Part No.	Description	Qty
C01	EVBT1200-C01	Cylinder Body	2
C02	EVBT1200-C02	Washer	2
C03	EVBT1200-C03	Seal	2
C04	EVBT1200-C04	Seal Ring	2
C05	EVBT1200-C05	External Circlip	2
C06	EVBT1200-C06	Piston Rod	2
C07	EVBT1200-C07	Oil Filler Plug Ø10	2
C08	EVBT1200-C08	Guide Sleeve	2
C09	EVBT1200-C09	Seal Ring	2

Item	Part No.	Description	Qty
C10	EVBT1200-C10	Dustproof Ring	2
C11	EVBT1200-C11	O-Ring (Ø30 x 2.65)	2
C12	EVBT1200-C12	Piston Rod	2
C13	MSP620.S	Machine Screw Pan Head Phillips M6 x 20mm	2
C14	SWM6.S	Spring Washer M6 Zinc	2
C15	GNM19S	Grease Nipple str 6 x 1.00mm single	4
C16	EVBT1200-C16	Throttle Valve	2

NOTE: It is our policy to continually improve products and as such we reserve the right to alter data, specifications and component parts without prior notice. There may be alternative versions of this product, please contact us should you require this information.

IMPORTANT: No liability is accepted for incorrect use of product. Spare parts must be fitted by a competent person

WARRANTY: Guarantee is 12 months from purchase date, proof of which will be required for any claim.

Hydraulic System Assembly

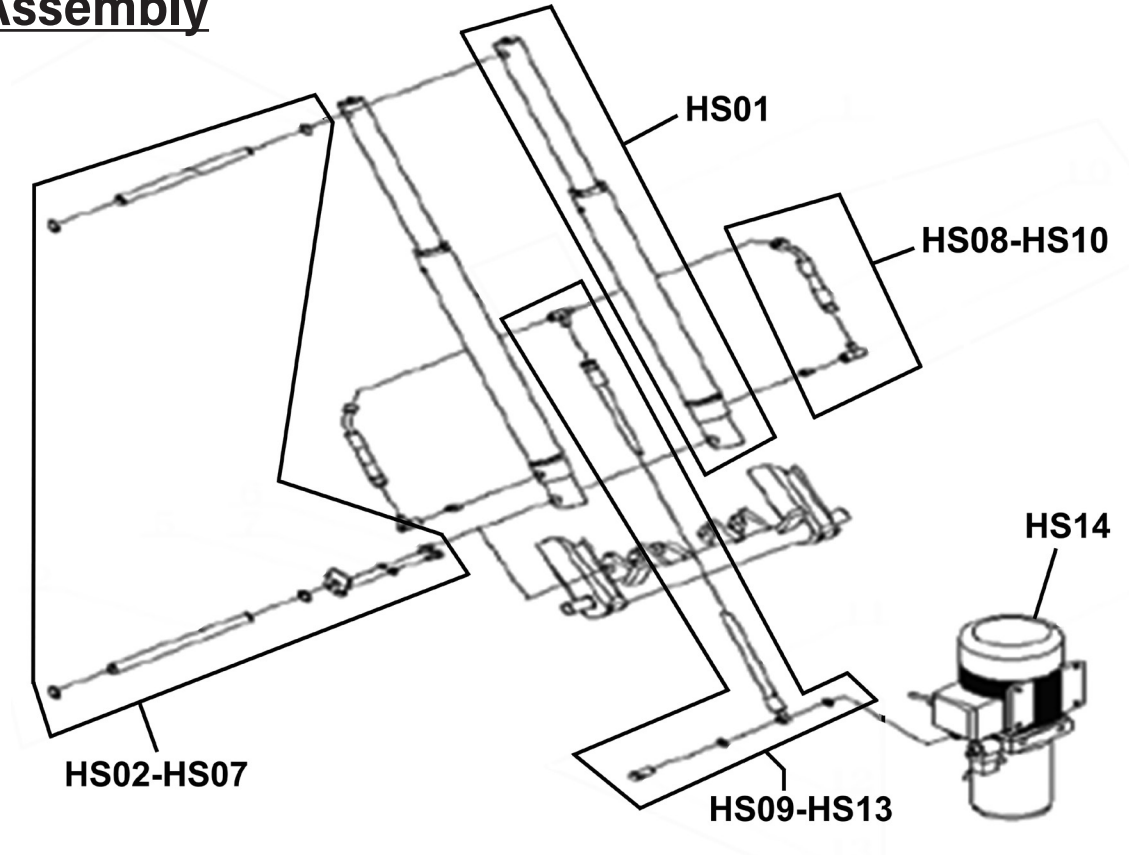

Item	Part No.	Description	Qty
HS01	EVBT1200-HS01	Complete Cylinder	1
HS02-HS07	EVBT1200-HS02-HS07	Oil Cylinder Shaft Assembly	1
HS08-HS10	EVBT1200-HS08-HS10	Oil Hose Assembly (A)	1

Item	Part No.	Description	Qty
HS09-HS13	EVBT1200-HS09-HS13	Oil Hose Assembly (B)	1
HS14	EVBT1200-HS14	Pump 0.75kW	1

NOTE: It is our policy to continually improve products and as such we reserve the right to alter data, specifications and component parts without prior notice. There may be alternative versions of this product, please contact us should you require this information.

IMPORTANT: No liability is accepted for incorrect use of product. Spare parts must be fitted by a competent person

WARRANTY: Guarantee is 12 months from purchase date, proof of which will be required for any claim.

Safety Components

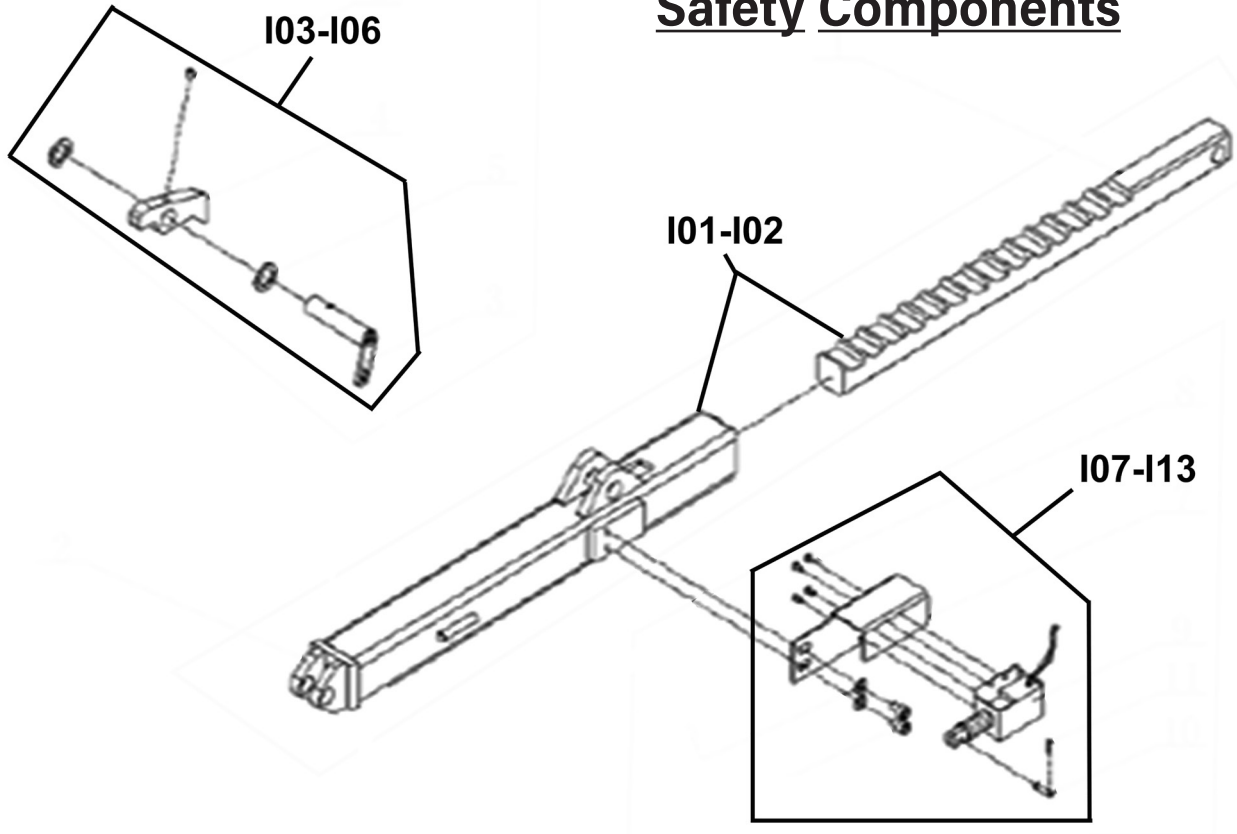

Item	Part No.	Description	Qty
I01-I02	EVBT1200-I01-I02	Electrical Unlocking System & Gear Assembly	1
I03-I06	EVBT1200-I03-I06	Latching Tongue Assembly	1

Item	Part No.	Description	Qty
I07-I13	EVBT1200-I07-I13	Electromagnetic Switch Assembly	1

NOTE: It is our policy to continually improve products and as such we reserve the right to alter data, specifications and component parts without prior notice. There may be alternative versions of this product, please contact us should you require this information.

IMPORTANT: No liability is accepted for incorrect use of product. Spare parts must be fitted by a competent person

WARRANTY: Guarantee is 12 months from purchase date, proof of which will be required for any claim.