

Item	Part No.	Description	Qty
1	EVBT1000-01	Platform	1
2	EVBT1000-02	External Circlip Ø20	2
3	EVBT1000-03	Platform Pin	2
4	EVBT1000-04	Lifting Arm Frame	1
5	EVBT1000-05	Lifting Rod Pin	2
6	EVBT1000-06	External Circlip Ø18	2
7	EVBT1000-07	Upper/Lower Roller	4
8	EVBT1000-08	External Circlip Ø22	4
9	EVBT1000-09	Supporting Shaft	2
10	EVBT1000-10	Rubber Cushion Ø30	6
11	EVBT1000-11	Jam Nut M12	6
12	EVBT1000-12	Cover Nut M12	4
13	EVBT1000-13	Lifting Arm Frame (Lower)	1

Item	Part No.	Description	Qty
14	EVBT1000-14	Lifting Cylinder Pin	2
15	EVBT1000-15	E-Ring Ø15	4
16	EVBT1000-16	Lower Central Axis	2
17	EVBT1000-V2-17	Frame Assembly	1
18	EVBT1000-18	Cylinder Assembly	1
19	EVBT1000-V2-19	Hydraulic Unit Assembly (Black)	1
20	EVBT1000-20	Elbow	4
21	EVBT1000-21	Adjustable Saddle	4
22	FWM12.S	Flat Washer M12 Zinc	4
23	SS1230.S	Hex Head Set Screw M12 X 30 Zinc	4
24	EVBT1000-24	Side Handle	4
25	SWM8.S	Spring Washer M8 Zinc	8
26	SS815.S	Hex Head Set Screw M8 X 15 Zinc	8

NOTE: It is our policy to continually improve products and as such we reserve the right to alter data, specifications and component parts without prior notice. There may be alternative versions of this product, please contact us should you require this information.

IMPORTANT: No liability is accepted for incorrect use of product. Spare parts must be fitted by a competent person

WARRANTY: Guarantee is 12 months from purchase date, proof of which will be required for any claim.

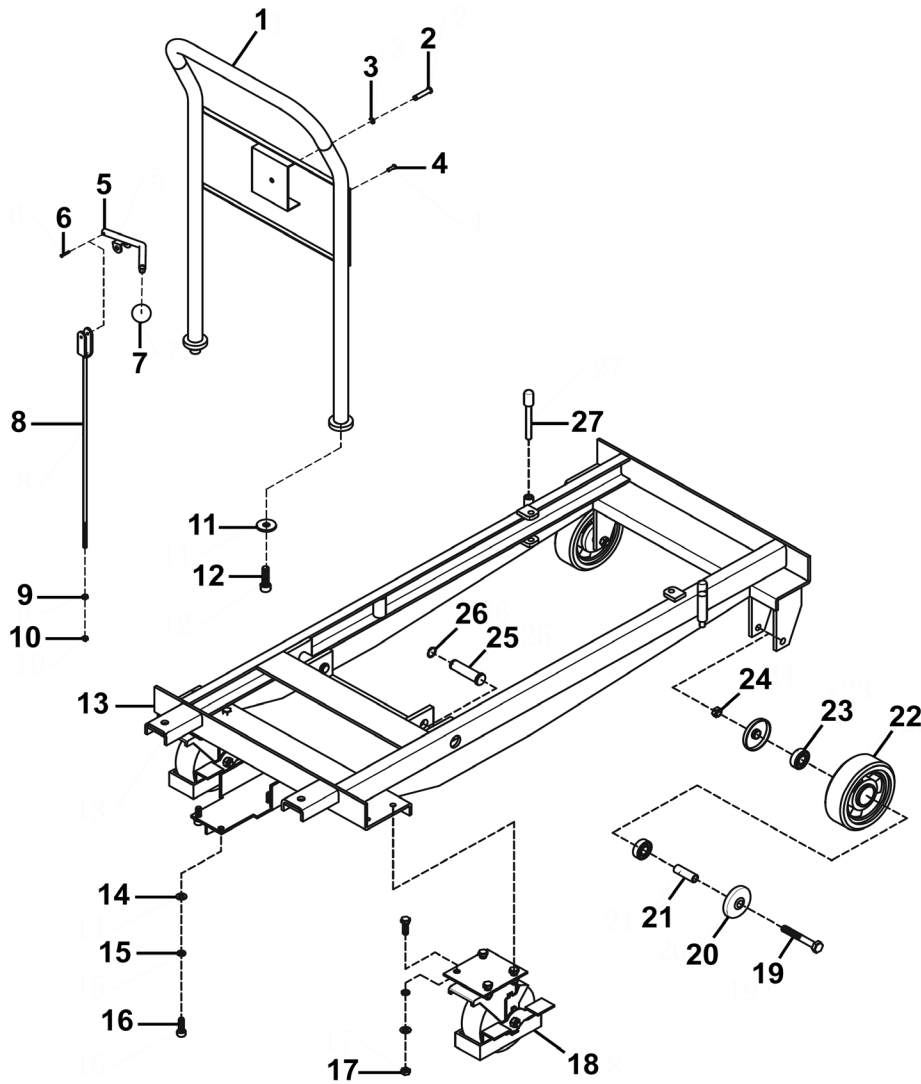

Item	Part No.	Description	Qty
1	EVBT1000-V2-17-01	Frame Handle (Black)	1
2	EVBT1000-17-02	Frame Handle Pin	1
3	EVBT1000-17-03	Split Ring Ø6mm	1
4	EVBT1000-17-04	Rivet Ø5 x 16mm	6
5	EVBT1000-17-05	Control Handle Lever	1
6	EVBT1000-17-06	Rivet Ø3 x 25mm	1
7	EVBT1000-17-07	Knob, Plastic, Spherical	1
8	EVBT1000-17-08	Handle Pull Rod Ass'y (c/w Parts 17-05,17-06 & 17-07)	1
9	SN6.S	Steel Nut M6 Zinc	1
10	NLN6.S	Nyloc Nut M6 Zinc	1
11	EVBT1000-17-11	Handle Seat Gasket	2
12	SS1240.S	Hex Head Set Screw M12 X 40 Zinc	2
13	EVBT1000-V2-17-13	Frame	1
14	FWM10.S	Flat Washer M10 Zinc	11

Item	Part No.	Description	Qty
15	SWM10.S	Spring Washer M10 Zinc	11
16	SS1030.S	Hex Head Set Screw M10 X 30 Zinc	11
17	SN10.S	Steel Nut M10 Zinc	8
18	EVBT1000-V2-17-18	Rear Wheel	2
19	HHB1290.S	Hex Head Bolt M12 x 90mm	2
20	EVBT1000-17-20	Bearing Cover	4
21	EVBT1000-17-21	Wheel Bushing	2
22	EVBT1000-V2-17-22	Front Wheel	2
23	B/6203ZZ	Bearing 6203zz	4
24	EVBT1000-17-24	Jam Nut M12	2
25	EVBT1000-17-25	Frame Pin	2
26	EVBT1000-17-26	External Circlip Ø20	2
27	EVBT1000-17-27	Limit Shaft	2

NOTE: It is our policy to continually improve products and as such we reserve the right to alter data, specifications and component parts without prior notice. There may be alternative versions of this product, please contact us should you require this information.

IMPORTANT: No liability is accepted for incorrect use of product. Spare parts must be fitted by a competent person

WARRANTY: Guarantee is 12 months from purchase date, proof of which will be required for any claim.