

ITEM	PART NO	DESCRIPTION
1	122/10.03.14	KNOB
2	122/10.05.09	PLASTIC HANDLE
3	122/10.05.10	BODY
4	122/11.09.03	SCREW(2.9x9.5)
5	122/11.09.05	SCREW
6	122/11.09.07	SCREW (SO)
7	122/11.09.08	SCREW (SO)
8	122/11.09.09	SCREW
9	122/12.03.10	COVER
10	122/13.01.26	WASHER
11	122/19.01.01	CIRCLIP
12	122/19.01.70	CIRCLIP
14	122/19.50.09	DUST STOP
15	AK289	DUST FREE SELF/ADH DA PAD 150m
16	B/629-2RS	BEARING, 629-2RS
17	B/6003-2RS	BEARING, 6003-2RS
18	122/22.09.10	BODY BOTTOM COVER
19	122/11.03.16	SCREW, 4 X 10
20	122/11.05.02	GRUB SCREW
21	122/14.01.36	COUNTERBALANCE
22	122/19.01.50	ECCENTRIC CIRCLIP
23	122/19.50.02	DUST STOP
24	B/6201-2RS	BEARING, 6201-2RS
25	122/32.01.17	EXCENTRIC SHAFT, LOWER
26	122/32.01.19	EXCENTRIC SHAFT
27	122/32.01.25	ECCENTRIC BODY (SO)
28	MC2CX1.0	MAINS CABLE BLK, 2 CORE, 1.0MM2
29	122/34.04.39	CABLE PROTECTION GUIDE
30	122/34.04.40	CABLE PROTECTION
31	122/34.06.50	SWITCH
32	122/34.07.14	BRUSH STOP
33	122/34.07.15	BRUSH STOP
34	122/34.07.16	CARBON BRUSH HOLDER
35	122/34.07.55	CARBON BRUSH (PAIR)
36	122/34.08.01	RUBBER RING
37	122/34.08.09	RUBBER RING
38	122/35.01.20	FIELD
40	122/50.01.10	ROTOR WITH FAN
41	122/62.01.22	DUST EXTRACTOR COVER
42	122/66.50.16	RUBBER DUST CONNECTION
43	122/34.03.30	CONDENSER
44	122/13.01.10	WASHER
45	122/19.01.90	C RING
46	122/22.55.50	BRUSH
47	122/19.50.03	WASHER
48	122/29.01.01	NUT (SO)
49	122/11.02.20	SCREW, 3 X 20

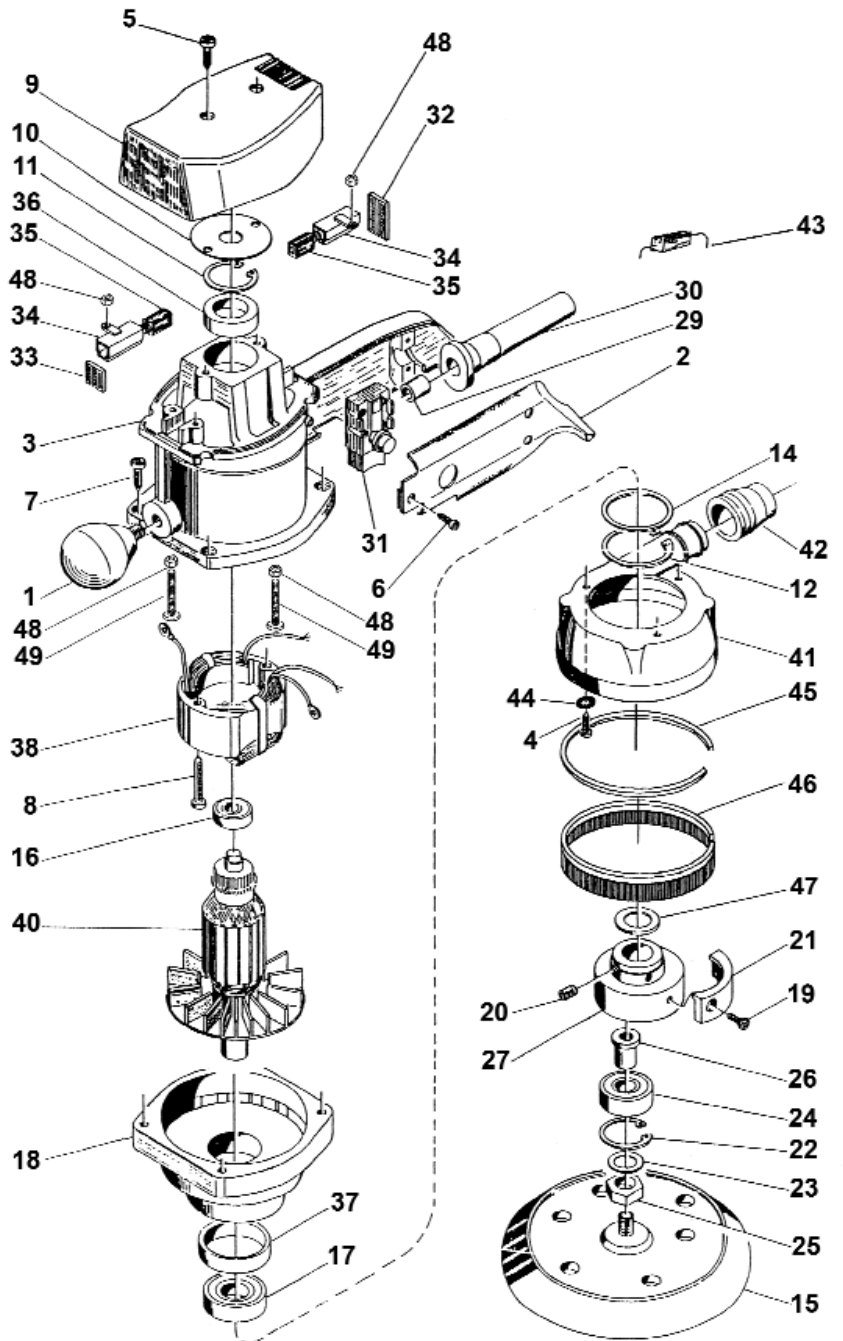

ISSUE NO. 1
 ISSUE DATE 01/02/06