

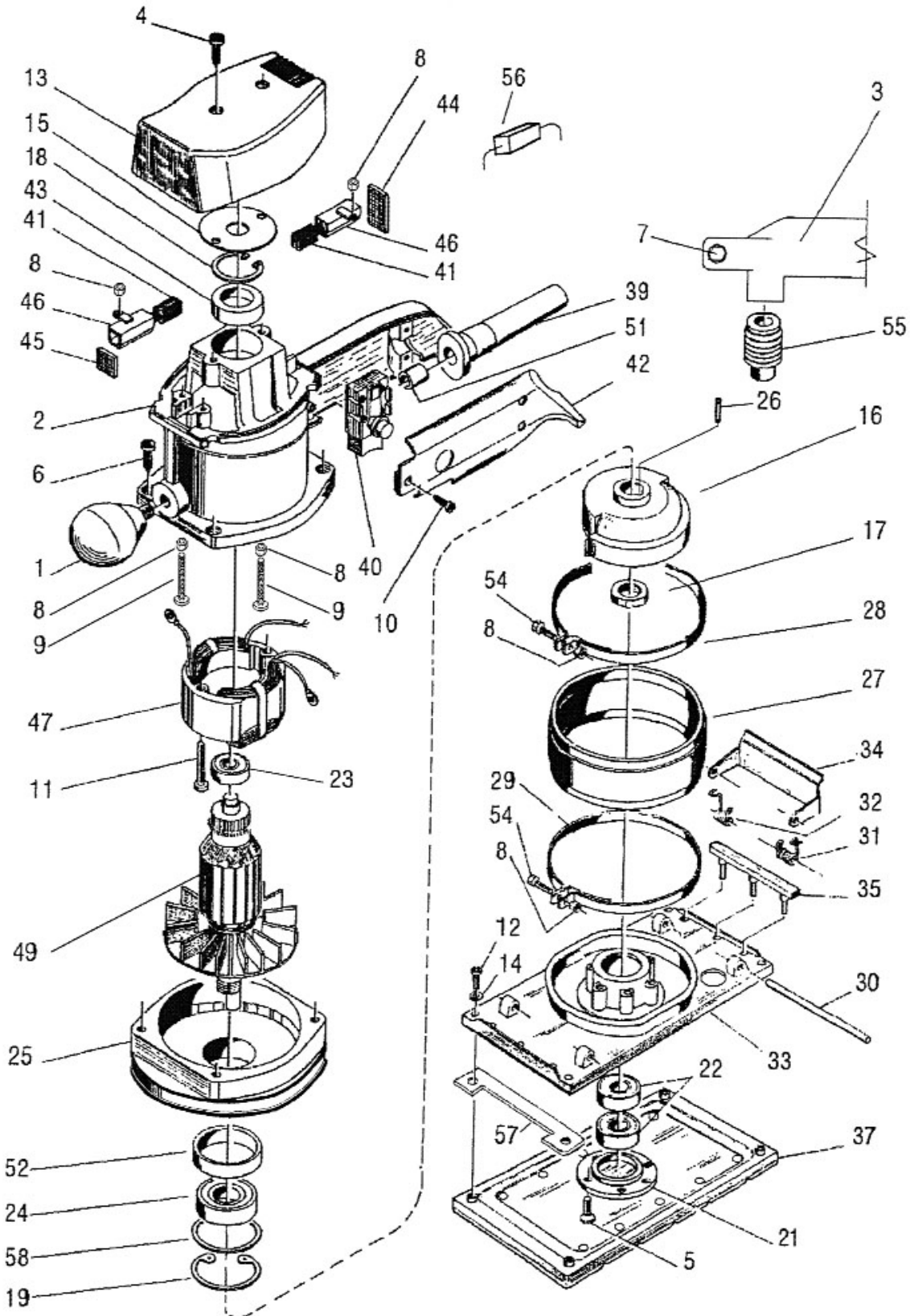

Parts Information:  
Flat Bed Orbital Dust-Free Sander 230V  
Heavy-Duty  
Model No: EM110/DFS.V2



**NOTE:** It is our policy to continually improve products and as such we reserve the right to alter data, specifications and component parts without prior notice.

**IMPORTANT:** No liability is accepted for incorrect use of product.

**WARRANTY:** Guarantee is 12 months from purchase date, proof of which will be required for any claim.

Sealey Group, Kempson Way, Suffolk Business Park, Bury St Edmunds, Suffolk. IP32 7AR



01284 757500



01284 703534



sales@sealey.co.uk



www.sealey.co.uk



Parts Information:  
**Flat Bed Orbital Dust-Free Sander 230V  
Heavy-Duty  
Model No: EM110/DFS.V2**

Item	Part No.	Description
1	122/10.03.14	Knob
2	122/10.05.10	Body
3	122/10.05.11	Vacuum Manifold
4	122/11.09.05	Screw
5	122/11.03.30	Screw
6	122/11.09.08	Screw
7	122/11.09.11	Screw
8	122/29.01.01	Nut
9	122/11.02.20	Screw, 3 x 20
10	122/11.09.07	Screw
11	122/11.09.09	Screw
12	122/11.09.12	RD Head S/T Screw m3.8 x 16 Black
13	122/12.03.10	Cover
14	122/13.01.01	M4 ext Tooth Washer Black
15	122/13.01.26	Disc m12
16	122/14.06.10	Lower Counterweight
17	122/14.06.11	Ring, Counterbalance
18	122/19.01.50	Eccentric Circlip
19	122/19.01.50	Eccentric Circlip
21	122/19.50.21	6 Holes Disc
22	B/6201ZZ	Bearing 6201ZZ
23	B/6203-2RS	Bearing 6203-2RS
24	B/629-2RS	Bearing 629-2RS
25	122/22.09.11	Motor Bottom Cover
26	122/23.01.01	Pin
27	122/24.05.15	Rubber Sleeve
28	122/24.50.02	Rubber Sleeve Clip

Item	Part No.	Description
29	122/24.50.04	Clip For Backing Plate
30	122/23.20.11	Lock Pin
31	122/25.02.20	Lock Spring - Right
32	122/25.02.21	Lock Spring - Left
33	122/26.05.12	Backing Plate
34	122/26.04.13	Paper Lock
35	122/26.04.15	Rubber Paper Lock
37	122/30.01.61	Rubber Plate
39	122/34.04.40	Cable Protection
40	122/34.06.50	Switch
41	122/34.07.55	Carbon Brush (Single)
42	122/10.05.09	Plastic Handle
43	122/34.08.01	Rubber Ring
44	122/34.07.14	Brush Stop
45	122/34.07.15	Brush Stop
46	122/34.07.16	Carbon Brush Holder
47	122/35.01.25	Stator
49	122/50.01.30	Rotor With Fan
51	122/34.04.39	Cable Protection Guide
52	122/34.08.09	Rubber Ring
54	122/11.02.01	Screw
55	122/68.01.10	Rubber Bellows
56	122/34.03.30	Condensor
57	122/17.30.35	Gasket
58	122/19.50.09	Dust Stop
59	DFS/AK3	Vac Hose 5mtr x 28mm (NOT SHOWN)

**NOTE:** It is our policy to continually improve products and as such we reserve the right to alter data, specifications and component parts without prior notice.

**IMPORTANT:** No liability is accepted for incorrect use of product.

**WARRANTY:** Guarantee is 12 months from purchase date, proof of which will be required for any claim.

**Sealey Group**, Kempson Way, Suffolk Business Park, Bury St Edmunds, Suffolk. IP32 7AR



01284 757500



01284 703534



sales@sealey.co.uk



www.sealey.co.uk